



Novanta
PHOTONICS

WHITEPAPER

CHALLENGES OF CO2 LASER AND SCAN HEAD SUBSYSTEM INTEGRATION

Challenges of CO₂ Laser and Scan Head Subsystem Integration

Authors: Daniel Schue, Justin Conroy, Malte Hemmerich

Abstract

CO₂ lasers are widely employed in various applications, including marking & coding, cutting, drilling & perforating and ablation, as well as industries ranging from converting to 3D Printing, where high speed and accurate manipulation of the laser beam is crucial. The laser source is usually selected for its pulse performance, optical output power, and wavelength, while the scan head is selected for its field & spot size, speed, and accuracy specifications. Thus, while each component is chosen for its individual performance characteristics, achieving optimal performance from the combined system presents a unique challenge for machine builders and laser integrators.

This paper delves into the intricacies of integrating CO₂ lasers and galvo scan heads to achieve complementary performance. It explores the critical factors of selecting the right mechanical, electrical and optical components, along with designing an optical beam path that is easy to align and cost-effective. Despite being underestimated, these aspects play a pivotal role in the overall success of the subsystem.

As a single-source supplier of these mission critical components, Novanta offers innovative solutions to streamline the integration process. By addressing the specific challenges and providing flexible subsystem configurations, Novanta facilitates optimizations and ease-of-use improvements, allowing OEM's and integrators to unlock the full potential of their laser subsystems.

Available Combinations of Novanta CO₂ Lasers and Scan Heads

In all laser-material processing, the desired quality and speed defines the best laser sources and beam manipulation components. [Novanta's Global Application Centers](#) have extensive experience with a wide variety of laser applications for a broad range of commercially available wavelengths (UV – IR), power levels (mW – kW), pulse lengths (fs – cw) and scan head apertures (10mm – 50mm) as well as control methods (analog, hybrid, digital). For the purposes of this paper, we assume that an appropriate CO₂-laser and an analog- or hybrid scan head have been selected, with readers being encouraged to refer to our commercial whitepapers "[Understanding Pulse Width Modulated CO₂-Laser Operation](#)" and "[Analog vs. Digital](#)," or to engage with our experts for in-depth discussions on specific application needs.

	Laser Name:	48-1	vi30/vi40	ti Series	P100/150	f201	p250	i401	P400
	Max. Average Power	10W	40W	60 -100W	150W	200W	250W	400W	400W
SCAN HEAD NAME	APERTURE SIZE	VALID COMBINATION							
MOVIA	10 mm	✓	✓	✓	✗	✗	✗	✗	✗
Versia	14 mm	✓	✓	✓	✓	✗	✗	✗	✗
Elephant E36	36 mm	✓	✓	✓	✓	✓	✓	✓	✓
Elephant E50	50 mm	✓	✓	✓	✓	✓	✓	✓	✓

Fig 1. Common Novanta CO₂ sub-system pairing.

Figure 1 shows the valid combinations of [CO₂ Lasers](#) and [analog/hybrid scan heads](#) that are available from Novanta. In general, larger scan head aperture sizes allow for smaller focal spot sizes and for higher acceptable laser powers, while smaller apertures allow for faster and more dynamic beam manipulation. Since smaller scan heads are typically lower priced than larger ones, it is paramount to check if the laser’s maximum power output (Pmax) does fit the scan head’s mirror aperture size (D) and mirror reflectivity (R) performance.

$$P_{max} = \frac{P_{max\ absorbed}}{1 - R\%} = \frac{\frac{D}{20}}{1 - R\%} = \frac{D}{20(1 - R\%)}$$

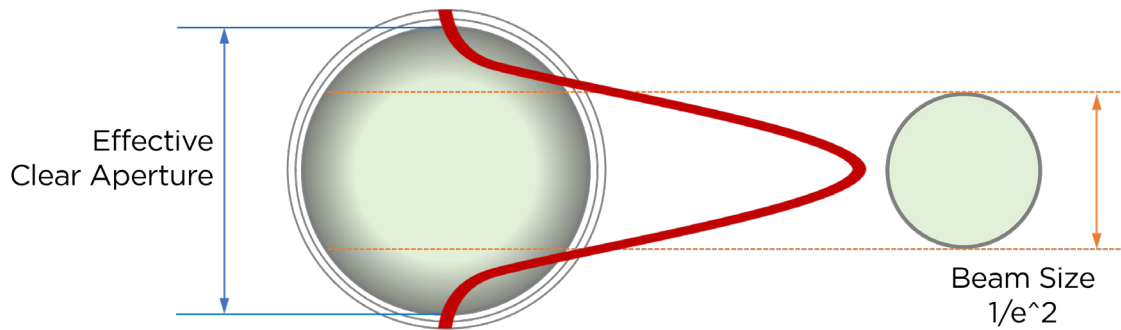

Fig 2. The 1/e² size vs. the total clear effective aperture.

In Gaussian optics, the raw entry beam size directly influences the resulting focused spot size of a scan head. To achieve the smallest focused spot size, it is desirable to optimally fill the input aperture of the scan head with the largest diameter beam. Typically, a laser beam’s width is reported as the 1/e² diameter on its datasheet, encompassing approximately 86.5% of the total energy, while the scan heads datasheet will give the effective clear aperture (see Figure 2). To make sure that 99% of the energy of the laser beam will pass through the scan head, the calculations below show that a safety factor of around 1.5x must be applied between the beam size given as 1/e²-value and the free aperture.

$$Power\ Loss = e^{-2 \cdot \frac{\left(\frac{Clear\ Aperture}{2}\right)^2}{\left(\frac{Beam\ Size}{2}\right)^2}} < 1\%$$

$$\left(\frac{Clear\ Aperture}{Beam\ Size}\right) = \sqrt{-\frac{1}{2} \cdot \ln(Power\ Loss)} > \sqrt{-\frac{1}{2} \cdot \ln(1\%)} = \sim 1.52$$

$$Beam\ Size < \frac{Clear\ Aperture}{1.52}$$

Fig 3. Power loss and ratio calculations for gaussian beams

A clear aperture to beam diameter ratio lower than 1.5 may result in significant diffraction rings and laser power loss through the system, leading to decreased marking or cutting performance, and shorter component lifetimes. A higher ratio will lead to increased power density on the optical components and a larger spot size in the focal area. Therefore, accurately matching the laser beam size with the specific scan head is of utmost importance.

Optical Matching of Laser Beam and Scan Head Aperture

The optimal performance of a scan head heavily relies on precise matching with the incoming laser beam. Laser beam collimation, ellipticity, mode, size, and input angle must be considered.

To address the challenges of matching laser specifications with the scan head and to account for the divergence of the laser beam, Novanta has carefully selected adjustable beam expanders from leading suppliers. These beam expanders play a crucial role in achieving optimal performance, allowing for effective beam shaping and size control.

Another critical aspect in the matching process is the beam alignment, which typically relies on free space optics. Although the long wavelength of CO₂ lasers is advantageous for processing papers, polymers, glass, and other organic materials, it also creates challenges for fiber delivery. The fiber technologies currently available absorb too much laser energy and do not have high enough transmission rates for most industrial applications. Thus, for most applications, and especially those involving CO₂ laser powers above 30W, free space beam propagation between the laser and scan head is the preferred approach.

Most CO₂ lasers exhibit some variation in the beam exit location and angle, and therefore require alignment into scan heads. The laser beam must be aligned with high precision to the center of the input aperture of the scan head. Any misalignment in the beam input will be amplified in the optical far field, and can lead to off-center beam outputs, power loss due to beam clipping, or will negatively affect the scan field.

The gold standard technique to address the alignment problem for free space optics involves implementing two individual mirrors and two targets into the beam path to accurately match the mechanical position to the optical axis of the scan head. While this technique is effective, it adds significant cost, space, and complexity to the subsystem. To simplify the alignment challenge, Novanta's Synrad brand has developed special baseplates and mounting feet for its CO₂ lasers. By carefully pre-aligning the individual lasers to their baseplate, Novanta can significantly limit the variation in laser beam position and angle at the scan head entrance aperture. This creates a very compact and accurate sub-system design.

The next segment will delve into the detailed design and alignment process of these mounting feet, highlighting the innovative approach that facilitates a seamless and high-performance integration of CO₂ lasers with galvanometer-based scan heads.

Laser Alignment Overview

Novanta pre-aligns CO₂ laser subsystems using several key components:

- A bracket with an aperture at a fixed position from the laser output
- A phosphorus screen
- A base rail-plate that accepts multiple laser configurations
- Laser alignment feet

During the alignment process, a wire-mesh mode screen is inserted into the aperture in the bracket. This screen glows at the beam contact point once sufficient power has been applied. The hole in the center of the mesh allows the center of the aperture to be precisely targeted.

When made to fluoresce via a blacklight, the phosphorus screen will indicate the position of a CO₂ laser beam that strikes it by visibly darkening. This screen is used in two reference points, or "fields": a "near field" point close to the output of the laser and a "far field" at a significant distance (>1m) from the laser. At least two reference points are needed when aligning a laser. A single reference point will only show the beam at that specific distance from the laser, and not the propagation orientation. For example, within the left graphic of Figure 4, the Laser is striking the center of the near field target, but the beam is travelling at such an angle that it is off target on the far field position.

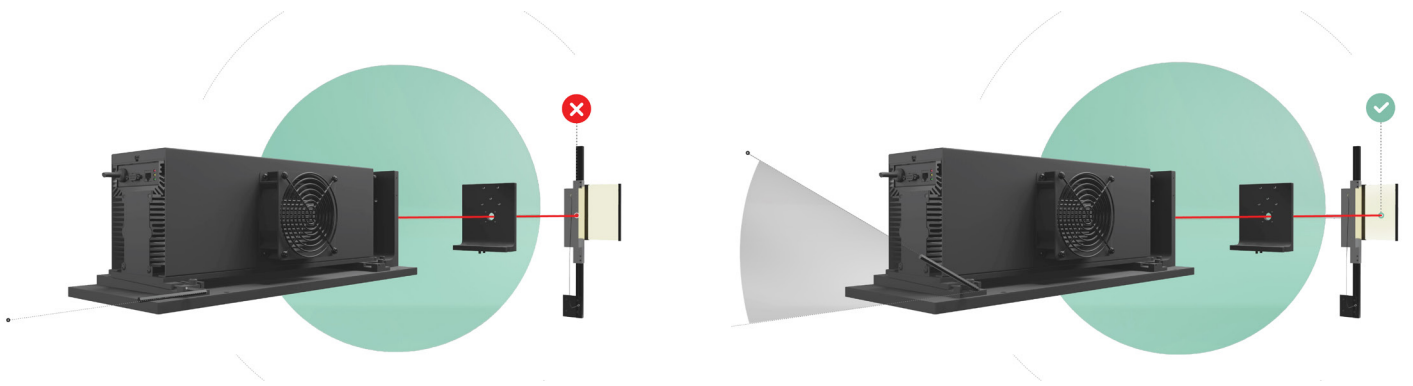

Fig 4. Phosphorus screen alignment process .

Laser alignment feet are used to adjust the laser beam position and orientation. These feet vary in the specifics of their design based on which model of laser they pair with, but all feet consist of two elements: a static element that attaches to the rail plate at a fixed position but allows for some play in attaching to the laser at different longitudinal rotation positions, and a variable element that allows for adjustments in height. Varying the height at both ends of the laser, as well as adjusting the longitudinal angle at which the feet are attached to the laser, allows the laser beam to be set on the precise path required by the scan head (see right graphic in Figure 4).

Shim-Based Feet Systems

The variable element of the feet has two main design modes, the first of which are the shim-based systems. For these systems the height of the feet can be adjusted by inserting shims of varying thicknesses, precision machined to match the laser model they pair with, between the static element of the foot and the laser.



Fig 5. Assembling shims on to the mounting feet (left) before laser is mounted (right).

Wedge-Based Feet System

Novanta has developed a second type of variable element used to set the height of the feet attached to the laser. This second system makes use of a wedge that can slide along an angled portion of the static foot. Here, the wedge attached determines the height of the foot as a whole. The advantage to this system is that it is analog rather than digital and the wedge position can be adjusted as precisely as needed to achieve the optimal height for the system as opposed to manually changing the height by the shim's thickness.

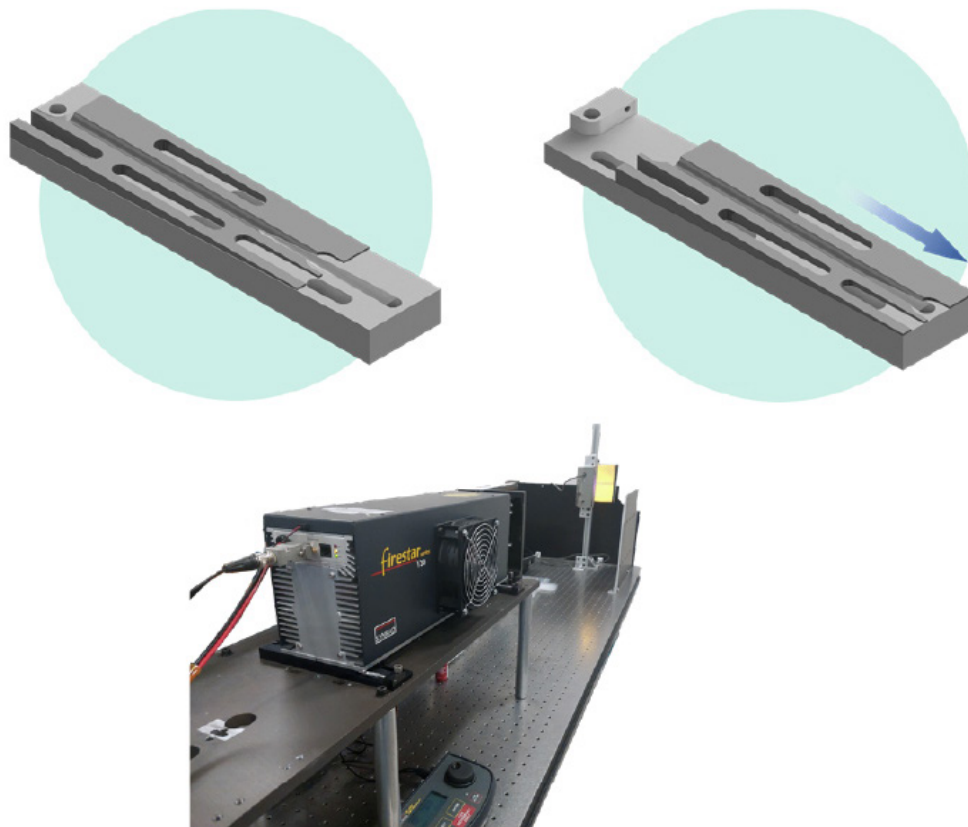

Fig 6. Adjusting wedge mounting feet (top) and laser mounting (bottom).

Full Overview of Typical CO₂ Laser and Scan Head Subsystem

Optimizing the performance of a laser and scan head subsystem requires consideration of more than just the optomechanical design. Novanta subsystems combine high performance lasers and scan heads with tested power supplies, as well as ScanMaster Controller (SMC) and ScanMaster Designer software. This immensely powerful controller and software package enables cutting edge application development and machine control.

Novanta offers multiple hybrid- and digital scan heads, including Novanta's 2-axis hybrid scan head [VERSIA](#), which is designed with performance and system integration in mind. VERSIA is built with a compact, industrial design and is ideal for versatile applications like micromachining and marking and coding. VERSIA features an IP54 rated enclosure, and intuitive, industry-standard input and outputs for easy integration. To enable users to monitor position feedback and other monitoring tools, VERSIA is engineered with bidirectional communication protocols.

This is thanks to Novanta’s digital servo design, which enables the servo board to carry multiple tunes that are individually optimized for specific applications.

The electronic design and software integration of a subsystem into a machine is not covered in this paper, but we encourage readers to get in contact with Novanta’s experts directly to discuss individual needs.

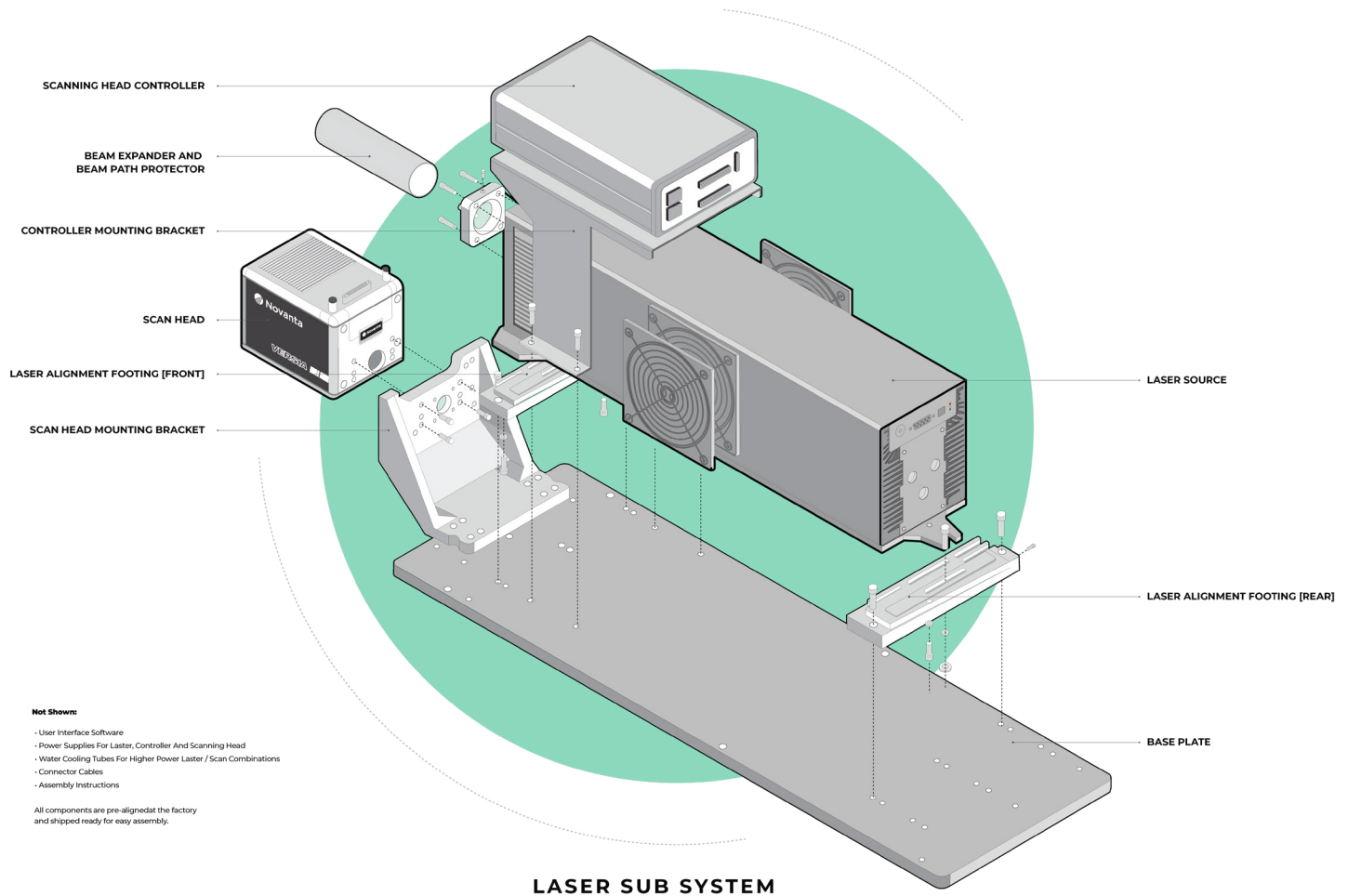

Fig 7. Common elements of Novanta CO₂ subsystem pairings.

Figure 7 provides an overview of the common elements included in Novanta’s CO₂ subsystem approach, simplifying setup while ensuring accuracy. However, successful transformation of a subsystem into a complete laser machine requires addressing additional considerations beyond the subsystem level. Fume extraction and part handling play vital roles in laser applications, significantly impacting achievable part quality. Compliance with Machine Safety standards requires a thorough assessment of the full machine. Environmental conditions within the machine may influence the need for purge gas and affect heat management and cooling.

While Novanta does not provide full turn-key systems, Novanta’s application experts can provide resources to 3rd party integrators and machine builders. Together collaborating with Novanta’s experts enables users to navigate these challenges effectively and achieve optimal results for their laser applications. By combining advanced technology with a comprehensive understanding of application needs and machine requirements, Novanta delivers reliable and high-performance CO₂ laser and scan head subsystems.

Conclusion

In conclusion, integrating CO₂ lasers and galvanometer-based scan head subsystems presents a unique set of challenges and considerations. Precise optical matching of the laser beam and scan head aperture is essential for achieving optimal performance. While attaining an entirely ideal scenario may never be achievable, approaching it as closely as possible by selecting the right opto-mechanical and electrical components can significantly enhance subsystem performance. Beam alignment is a critical aspect that should not be underestimated. Novanta has developed a laser alignment strategy that combines cost effectiveness and accurate calibration. By addressing alignment challenges with specially designed baseplates and mounting feet, Novanta streamlines the integration process and ensures a compact and efficient subsystem design.

Beyond optical and mechanical considerations, successful laser applications require a holistic approach. Novanta's comprehensive subsystems combine lasers and scan heads with tested power supplies and advanced control systems like the ScanMaster Controller (SMC) and ScanMaster Designer Software. These powerful tools empower integrators to develop applications with precision and efficiency.

Incorporating Novanta's modular subsystem approach can help machine builders and laser integrators overcome challenges and unlock the full potential of their laser systems. By providing a seamless integration process, Novanta enables customers to drive innovation and success across various industries.

We invite all interested parties to engage directly with Novanta's experts to discuss individual needs and explore customized solutions tailored to their specific requirements. With Novanta's cutting-edge components and expertise, integrators can confidently tackle the complexities of CO₂ laser and scan head integration, achieving outstanding results in their laser applications.

Novanta Benefits

Novanta is uniquely positioned to solve even the most complex challenges for OEMs, system integrators, and end-use customers seeking to advance their manufacturing processes with high precision laser systems. With some of the most well-known brands in the industry and in-country application and service support, Novanta delivers reliable, precise, and durable components and sub-systems.

Our Applications Testing Labs offer application and proof-of-concept testing to OEMs, system integrators, material manufacturers, processors, and end-users of automated machinery. Novanta Application Engineers are laser processing experts, and understand the parameters that will ensure successful, efficient laser processing. Using laser and beam steering equipment from well-known Novanta brands, our Application Engineers will determine the key product parameters and processing know-how to achieve the desired results.

CONTACT US

E photonics@novanta.com | photonics.china@novanta.com | photonics.japan@novanta.com

W novantaphotonics.com