

## FH Flyer 2-Axis Scan Head

# COMPLETE 2-AXIS SCAN HEAD SOLUTION FOR FAST, EASY INTEGRATION

An effective CO<sub>2</sub> laser marking, engraving, and cutting solution for OEMs and system integrators alike. The FH Flyer marks at speeds up to 300 ips (7620 mm/s) in either static (index) or dynamic (tracking) laser-marking applications.

## PAIR WITH ANY SYNRAD CO<sub>2</sub> LASER FROM 10 TO 150 WATTS FOR AN EFFECTIVE OUT-OF-THE-BOX LASER MARKING, ENGRAVING, AND CUTTING SOLUTION

A pre-aligned mounting kit from the factory pairs the FH Flyer with any Synrad CO<sub>2</sub> laser from 10 to 150 Watts to create ready-to-work laser processing sub-system. The FH Flyer saves considerable engineering time and effort associated with sourcing and aligning separate components from different manufacturers, making integration fast and easy.



## DESIGNED FOR OEMs AND SYSTEM ARCHITECTS

- Customized to suit application needs, including options for Synrad laser model and scan head field size or focused spot size
- Simplified set-up with pre-aligned mounting kit for 10 Watt to 150 Watt lasers
- Optional four-position L-bracket allows users to easily mount the Flyer scan head in its standard position (lens down) as well as in +90, -90, and 180 degree rotations
- Built-in Ethernet interface to communicate with the marking computer, a server, or network share with additional Input/Output capability
- User-accessible, fully isolated 15 V power source for powering external I/O devices
- Built-in gas purge port to lower the risk of contaminating internal optical surfaces to ensure consistent processing performance
- Intuitive job design and control with included WinMark Pro software package
- All digital technology enables easy setup and on-the-fly changes. Built-in Ethernet and I/O interfaces allow the scan head to be controlled via computer (tethered) or operate independently (standalone)
- Static or dynamic tracking modes allow FH Flyer to be easily integrated into a custom processing station or onto full production lines

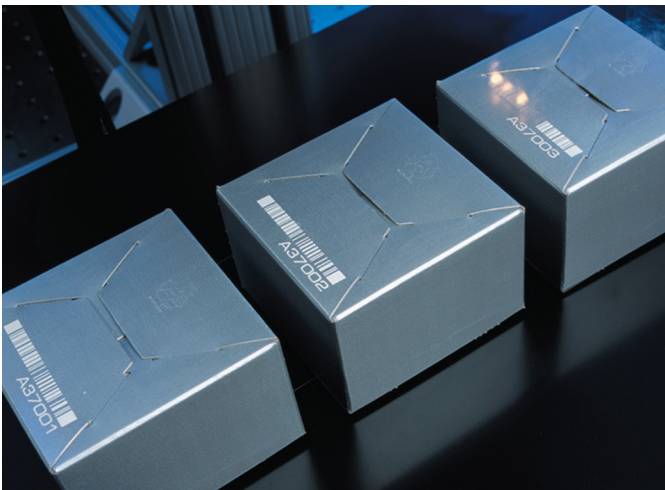

### WinMark Pro Software

WinMark Pro is custom software designed to operate with Synrad scan heads. Files can be created in the software itself, or imported from your favorite design software. Each object within the design can be assigned unique parameters to optimize application performance and allow many processes (marking, cutting, engraving, and others) to be performed in a single job file. WinMark can also be used to prepare the scan head for static or dynamic on-the-fly operation.

## FH FLYER SPECIFICATIONS

| Focusing Lens Options                          |  |              |                     |           |           |
|--|--|--------------|---------------------|-----------|-----------|
| F-Theta Lens Options                           | 80 mm  | 125 mm       | 125 HP <sup>1</sup> | 200 mm    | 370 mm    |
| Field Size (mm)                                | 33.5 x 41.2  | 85.7 x 105.6 | 80.4 x 99           | 134 x 165 | 241 x 297 |
| Spot Size 1/e <sup>2</sup> (µm)                | 116  | 180          | 180                 | 290       | 540       |
| Working Distance <sup>2</sup> typical (mm)     | 74 ± 1   | 128 ± 2      | 125 ± 2             | 190 ± 3   | 350 ± 5   |
| Depth of Field typical (mm)                    | ± 0.4  | ± 1.5        | ± 1.5               | ± 2.5     | ± 10      |
| Scan Speed mm/s (inches/s)                     | 4953 (195)   | 7620 (300)   |                     |           |           |
| Operation                                      |  |              |                     |           |           |
| Operating Temperature Range                    | 0 to 40° C   |              |                     |           |           |
| Electrical Input                               | 30 VDC, 4A, 8A Peak  |              |                     |           |           |
| Heat Load, generated by the head               | 90 Watts nominal, 120 Watts max  |              |                     |           |           |
| Continuous Beam Input Power, Max               | 125 mm lens: 40 Watts; All others: 200 Watts                             |              |                     |           |           |
| Physical                                       |  |              |                     |           |           |
| Dimensions LxWxH mm (inches)                   | 214.63 x 137.2 x 136.9 (8.45 x 5.40 x 5.39)                              |              |                     |           |           |
| Weight kg (lbs.)                               | 4.4 (9.6)  |              |                     |           |           |
| Gas Purge (optional)                           | Clean and dry air or nitrogen; 2 - 5 PSI                                 |              |                     |           |           |
| Four-Position L-Bracket (optional)             | Allows standard head position (lens down), +90°, -90° and 180° rotations |              |                     |           |           |
| Communication                                  |  |              |                     |           |           |
| Tethered: PC control and mark file creation    | WinMark, ActiveX   |              |                     |           |           |
| Standalone: allows API, PLC, PC or I/O control | ActiveX, Modbus I/P, Master Control File                                 |              |                     |           |           |
| I/O  | 8 inputs/8 outputs<br>Built-in user accessible 15 V power source         |              |                     |           |           |

1. 125 HP lens for use with lasers 40 watts or higher.

2. The typical focal length (working distance) is marked on each lens mount, since the actual working distance may vary from lens to lens. For this reason, it is important to provide z-axis adjustment between the FH Flyer scan head and the material surface. Consult your scan head final test report for the exact measured working distance.

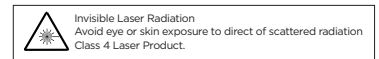

## FH FLYER RECOMMENDED APPLICATIONS



Enable fast, easy tracking and identification by applying permanent marks, text, and codes to a wide variety of materials.



Easily applies permanent alpha numeric codes, barcodes, text, and expiration dates to a variety of packaging materials that will not smear or rub off.



Enhance tactile experience or enable quick identification of organic materials by adding distinctive texture, contours, marks, or text.

## FH FLYER TECHNICAL ILLUSTRATIONS

Dimension are in mm (inches)

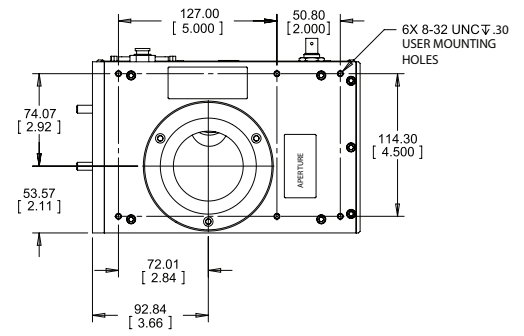
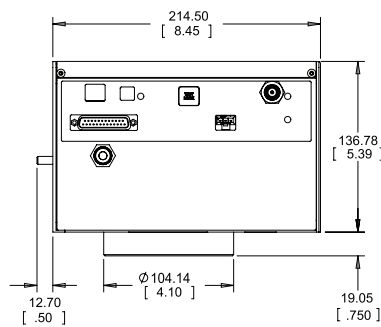
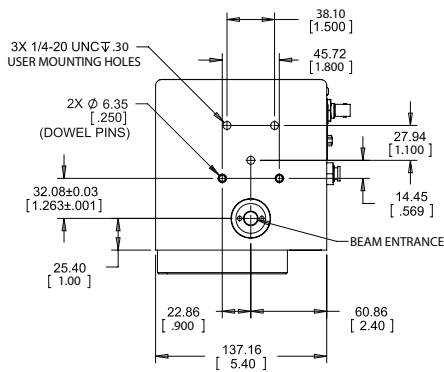

Scan head, Synrad CO<sub>2</sub> laser (10 - 150 W) and alignment fixture

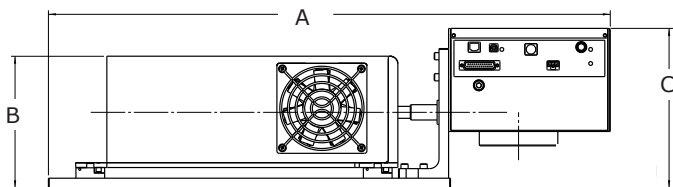

| Laser Model             | Synrad Laser |              |                         |               |                |
|-------------------------|--------------|--------------|-------------------------|---------------|----------------|
|                         | 48-1 (10 W)  | v30 (30 W)   | ti Series (60/80/100 W) | p100 (100 W)  | p150 (150 W)   |
| A Dimension mm (inches) | 740 (29.4)   | 745 (29.35)  | 974 (38.35)             | 977 (38.47)   | 1091.3 (42.97) |
| B Dimension mm (inches) | 135.3 (5.33) | 173 (6.80)   | 177 (6.94)              | 181.6 (7.15)  | 181.6 (7.15)   |
| C Dimension mm (inches) | 211.5 (8.33) | 211.5 (8.33) | 211.5 (8.33)            | 273.1 (10.75) | 273.1 (10.75)  |

## CONTACT US

### Americas & Asia Pacific

Novanta Headquarters  
 Bedford, USA  
 P +1-781-266-5700  
 Photonics@Novanta.com

### Europe, Middle East, Africa

Novanta Europe GmbH  
 Wackersdorf, Germany  
 P +49-9431-7984-0

Milan, Italy  
 P +39-039-793-710  
 Photonics@Novanta.com

### China

Novanta Sales & Service Office  
 Shenzhen, China  
 P +86-755-8280-538

Suzhou, China  
 P +86-512-6283-7080  
 Photonics.China@Novanta.com

### Japan

Novanta Service & Sales Office  
 Tokyo, Japan  
 P +81-3-5753-2460  
 Photonics.Japan@Novanta.com



[novantaphotonics.com](http://novantaphotonics.com)