

# OEM ti Series Operator's Manual

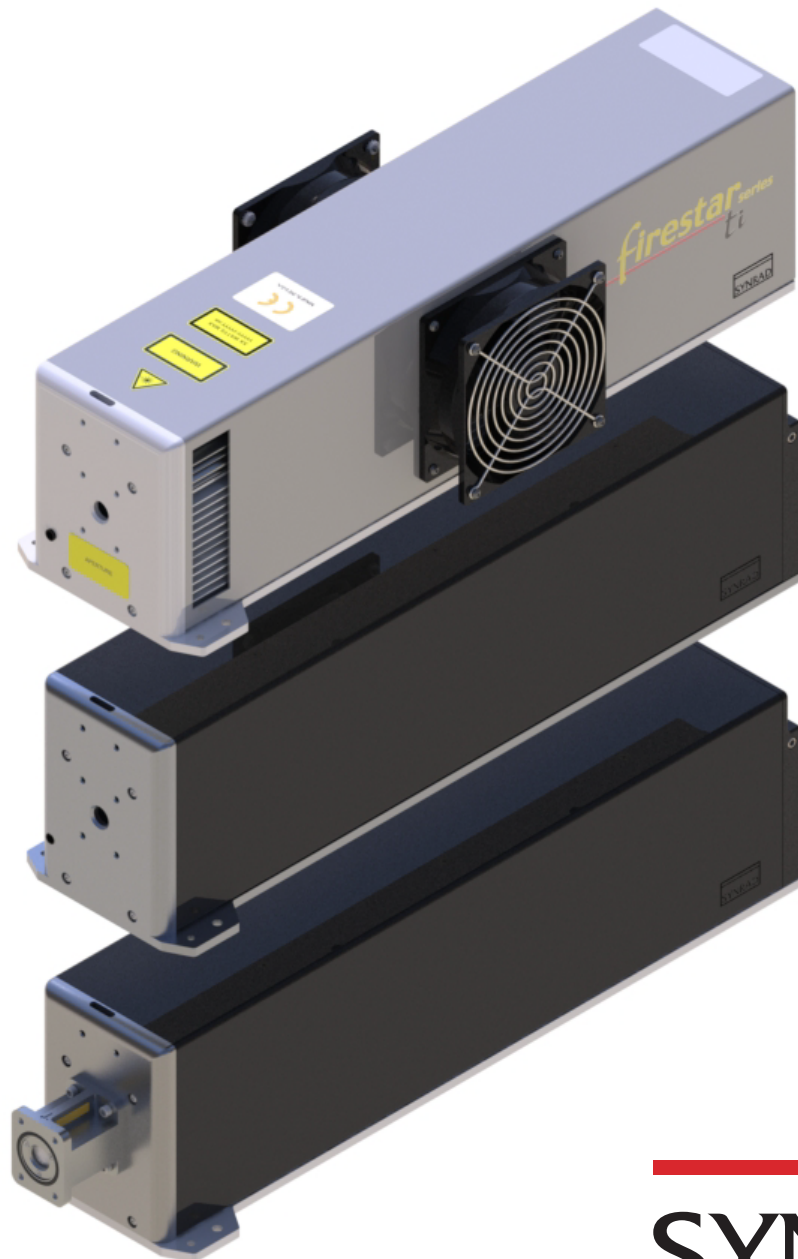

---

# SYNRAD

A Novanta Company

4600 Campus Place  
Mukilteo, WA 98275  
1.800.SYNRAD1

tel 1.425.349.3500

fax 1.425.349.3667

e-mail [synrad@synrad.com](mailto:synrad@synrad.com)

web [www.synrad.com](http://www.synrad.com)

# **OEM ti Series Operator's Manual**

ti60, ti80, ti100 Version 2.5

SYNRAD® is a registered trademark of ©Novanta Corporation. Novanta Corporation 2019. All Rights Reserved.  
No reproduction without written authorization.

July 2019

# Table of contents

## Introduction 1

- Introduction ..... 6
- Firestar ti-Series™ Trademark & Copyright information..... 7
- Warranty information ..... 8
- SYNRAD Service & Support ..... 9
- SYNRAD Headquarters ..... 9
- Sales and Applications ..... 9
- Customer Service ..... 9
- Technical Support ..... 9
- European Headquarters ..... 10
- Guidelines & Content..... 11
- Unpacking/packing, Storage/shipping, Mounting, Connecting, Cooling..... 11
- ti-Series™ Nomenclature..... 13

## Laser Safety 2

- Laser Safety..... 15
- Ti60 label locations ..... 20
- Ti80 label locations ..... 21
- Ti100 label locations..... 22
- Compliance..... 23
- Center for Devices and Radiological Health (CDRH) requirements..... 23
- Federal Communications Commission (FCC) ..... 24
- Requirements ..... 24
- European Union (EU) requirements..... 25

## Operation 3

- Controls and indicators ..... 31
- ti-Series front panel ..... 31
- ti-Series water-cooled rear panel ..... 32
- ti-Series side panel (SA air-cooled Models Only) ..... 34

## Technical Reference 4

- Technical reference summary ..... 35
- Technical overview ..... 36
- Introduction ..... 36
- Ti-Series Laser tube..... 36
- Optical resonator..... 36
- Controlling Laser Power..... 37
- Optical Setup ..... 38
- Assist Gas Specifications..... 39
- Cooling..... 39
- Control signals..... 42
- Operating modes ..... 45

# Table of contents

## Technical Reference 4

- User I/O connection summary.....48
- Input/output signals .....48
- Input signals.....52
- Output signals .....55
- Sample I/O circuits.....58
- DB-9 pin connections .....62
- DB-9 pin descriptions .....62
- 48 VDC fan speed control.....64
- Isolated cooling fan connections .....67
- Integrating ti-Series safety features.....69
- Keyswitch functions .....69
- Shutter functions.....70
- Remote interlock functions .....71
- ti-Series general specifications.....72
- Technical Drawings.....78

## Maintenance & Troubleshooting 5

- Maintenance and Troubleshooting .....87
- Introduction .....87
- Maintenance .....88
- Disabling the Ti-Series™ laser.....88
- Daily inspections .....88
- Storage/shipping.....89
- Coolants.....89
- Optics and contaminants .....90
- Cleaning guidelines.....91
- Required cleaning materials.....91
- Cleaning optics .....92
- Troubleshooting .....93
- Introduction .....93
- Status LED's.....93
- Laser fault indications.....97
- Keyswitch lasers .....97
- Over temperature fault .....97
- Under/over voltage fault.....97
- RF Drive Switch fault .....98
- PWM Drive fault .....98
- No-Strike condition .....98
- Remote interlock condition.....98
- Over temperature fault .....99
- Under/over voltage fault.....99
- RF Drive Switch fault .....99
- PWM Drive fault .....99

# Table of contents

## Maintenance & Troubleshooting 5

No-Strike condition .....99  
Beam delivery optics..... 103

## Appendix

Appendix..... 104  
Stabilized ti Series laser addenda ..... 105  
Physical Specifications:..... 105  
Stability Specifications: ..... 105  
Operation: ..... 105  
Technical Reference:..... 105  
The minimum power supply requirement for the ti100p laser is: ..... 106

## Index

Index ..... 107

# Introduction

# 1

## Introduction

- Ti-Series™ Trademark, Copyright, & Contact information
- Ti-Series Sales, support, guidelines and contents description
- Ti-Series Nomenclature

### Important Note:



This Operation Manual explains operation activities related to ti-Series lasers. If you cannot operate the unit using the information described in this manual, contact SYNRAD® (+1.425.349.3500) or an authorized SYNRAD Distributor.

The Quick Start Guide (QSG) <http://www.synrad.com/synrad/docroot/resources/libraries/quickstart> explains how to quickly unpack and assemble Series 48 lasers. Please reference the QSG along with the information within this manual.

Lift the laser only by the mounting feet or baseplate. Do not lift or support the laser by its cooling fittings.

Please reference the Quick Start Guide for unpacking, mounting, and connecting.

Failure to properly package the laser using SYNRAD shipping box and foam/cardboard inserts as shown in Packaging Instructions may void the warranty. Customers may incur additional repair charges due to shipping damage caused by improper packaging.

Before beginning any maintenance or inspections of your ti-Series laser, be sure to completely disable the laser by disconnecting the DC Power cable (or cables) from the rear of the laser.

### Caution Possible Equipment Damage



**SYNRAD does not recommend vertical or head down configurations.**

Please contact the factory for limitations as a vertical orientation increases the risk of damage to the lasers optics.

A **risk of exposure** to toxic elements may result when certain optical or beam delivery components are damaged. In the event of damage to laser, marking head, or beam delivery optics, contact SYNRAD®, or the optics manufacturer for handling instructions.

If you **operate your laser dirty or dusty environments**, contact SYNRAD about the risks of doing so and precautions you can take to increase the longevity of your laser, marking head, and associated optical components.

# Introduction

Service & Support information

## ti-Series™ Trademark & Copyright information

SYNRAD® and ti-Series are registered trademarks of SYNRAD.

All other trademarks or registered trademarks are the property of their respective owners.

2018 by SYNRAD.  
All rights reserved.

# Introduction

## Warranty information

### Warranty information

This is to certify that ti-Series lasers are guaranteed by SYNRAD® to be free of all defects in materials and workmanship for a period of two years from the date of shipment. This warranty does not apply to any defect caused by negligence, misuse (including environmental factors), accident, alteration, or improper maintenance. This includes, but is not limited to, damage due to corrosion, condensation, or failing to supply properly conditioned purge gas.

We request that you examine each shipment within 10 days of receipt and inform SYNRAD of any shortage or damage. If no discrepancies are reported, SYNRAD shall assume the shipment was delivered complete and defect-free.

If, within one year from the date of purchase, any part of the ti-Series laser should fail to operate, contact the SYNRAD Customer Service department at 1.800.SYNRAD1 (outside the U.S. call 1.425.349.3500) and report the problem. When calling for support, please be prepared to provide the date of purchase, model number and serial number of the unit, and a brief description of the problem. When returning a unit for service, a Return Authorization (RA) number is required; this number must be clearly marked on the outside of the shipping container in order for the unit to be properly processed. If replacement parts are sent to you, then you are required to send the failed parts back to SYNRAD for evaluation unless otherwise instructed.

If your ti-Series laser fails within the first 45 days after purchase, SYNRAD will pay all shipping charges to and from SYNRAD when shipped as specified by SYNRAD Customer Service. After the first 45 days, SYNRAD will continue to pay for the costs of shipping the repaired unit or replacement parts back to the customer from SYNRAD. The customer, however, will be responsible for shipping charges incurred when sending the failed unit or parts back to SYNRAD or a SYNRAD Authorized Distributor. In order to maintain your product warranty and to ensure the safe and efficient operation of your ti-Series laser, only authorized SYNRAD replacement parts can be used. This warranty is void if any parts other than those provided by SYNRAD are used.

SYNRAD and SYNRAD Authorized Distributors have the sole authority to make warranty statements regarding SYNRAD products. SYNRAD and its Authorized Distributors neither assumes nor authorizes any representative or other person to assume for us any other warranties in connection with the sale, service, or shipment of our products. SYNRAD reserves the right to make changes and improvements in the design of our products at any time without incurring any obligation to make equivalent changes in products previously manufactured or shipped. Buyer agrees to hold SYNRAD harmless from any and all damages, costs, and expenses relating to any claim arising from the design, manufacture, or use of the product, or arising from a claim that such product furnished buyer by SYNRAD, or the use thereof, infringes upon any Patent, foreign or domestic.



# Introduction

## Service & Support information

## SYNRAD Service & Support

### SYNRAD Headquarters

SYNRAD worldwide headquarters are located north of Seattle in Mukilteo, Washington. U.S.A. Our mailing address is:

SYNRAD  
4600 Campus Place  
Mukilteo, WA 98275  
U.S.A.

Phone us at: 1.800.SYNRAD1 (1.800.796.7231)  
Outside the U.S.: +1.425.349.3500  
Fax: +1.425.349.3667  
E-mail: [synrad@synrad.com](mailto:synrad@synrad.com)

### Sales and Applications

SYNRAD Regional Sales Managers work with customers to identify and develop the best CO<sub>2</sub> laser solution for a given application. Because they are familiar with you and your laser application, use them as a first point of contact when questions arise. Regional Sales Managers also serve as the liaison between you and our Applications Lab in processing material samples per your specifications. To speak to the Regional Sales Manager in your area, call SYNRAD at 1.800.SYNRAD1.

### Customer Service

For assistance with order or delivery status, service status, or to obtain a Return Authorization (RA) number, contact SYNRAD at 1.800.SYNRAD1 and ask to speak to a Customer Service representative, or you can email us by sending a message to [customercare@synrad.com](mailto:customercare@synrad.com).

### Technical Support

SYNRAD Regional Sales Managers are able to answer many technical questions regarding the installation, use, troubleshooting, and maintenance of our products. In some cases, they may transfer your call to a Laser, Marking Head, or Software Support Specialist. You may also e-mail questions to the Technical Support Group by sending your message to [support@synrad.com](mailto:support@synrad.com).

### Reference materials

Your Regional Sales Manager can provide reference materials including Outline & Mounting drawings, Operator's Manuals, Technical Bulletins, and Application Newsletters. Most of these materials are also available directly from SYNRAD web site at <http://www.synrad.com>.

# Introduction

## European Headquarters

### European Headquarters

For assistance in Europe, contact SYNRAD®European subsidiary, Synrad Europe, at:

©Novanta Distribution (USD) GmbH  
Parkring 57-59  
85748 Garching bei München, Germany

Phone: +49 89 31707-0

E-mail: [service-europe@synrad.com](mailto:service-europe@synrad.com)

# Introduction

## Guidelines & Content Description

### Guidelines & Content

Refer to the drawings when installing and operating your ti-Series™ laser.

- Unpacking/Packing, Storage/Shipping, Mounting, Connecting, Cooling
- Ti-Series nomenclature/features

### Unpacking/packing, Storage/shipping, Mounting, Connecting, Cooling

SYNRAD® recommends saving all of the laser's original packaging. It's unique design assists in preventing damage to your laser during storage, relocation and/or shipping.

Reference our Quick Start Guide Series at [Synrad.com](http://www.synrad.com). Additional information can also be found in the Technical Reference chapter within this manual.

### Contents description

Each item below is also listed in tables that follow:

**SYNRAD® OEM ti-Series Laser** – for cutting, welding, drilling, and marking a wide variety of products and materials.

**Customer Communication Flier ti-Series**– Instead of the laser manual CD, please follow the instructions for our latest laser manual(s) located here: <http://www.synrad.com/synrad/doc-root/resources/libraries/manuals>.

**Mounting kit** – Contains three each 1/4-20 x 5/8" UNC capscrews are provided for fastening to 90 degree adaptor fittings for either 1/2-inch standard or 12mm metric cooling tubing.

**Spare Fuse** – Two fast-acting mini ATO-type fuse protects ti-Series internal circuitry.

**Final Test Report (not shown)** – Contains data collected during the laser's final pre-shipment test.

**Cooling Kit (water-cooled lasers only)** – Adapts the laser's straight 1/2-inch coolant fittings to 90 degree adaptor fittings for either 1/2-inch standard or 12mm metric cooling tubing.

# Introduction

## Guidelines & Content Description

Figure 1-1 ti-Series™ ship kit contents.

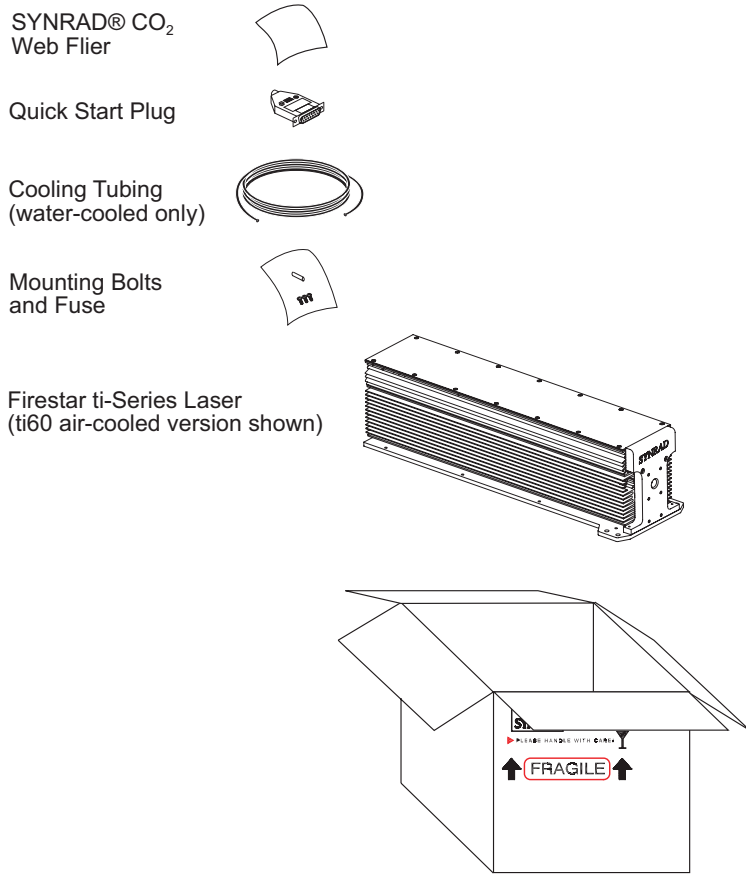

Table 1-1 ti-Series ship kit contents.

Shipping Box Contents	Qty	Shipping Box Contents	Qty
ti-Series Laser .....	1	Mounting Bolts .....	3
Customer flier .....	1	Cooling Kit .....	(as Required)
Final Test Report (not shown) .....	1	Spare Fuses (not shown) .....	(as Required)
Cooling Tubing .....	1		
DC Power Cable Set (not shown) ...	1		

# Introduction

## Guidelines & Content Description

### ti-Series™ Nomenclature

The ti-Series nomenclature section includes:

- Model numbers
- ti-Series laser versions

The last three characters in the ti-Series model number serve to designate the functional category, cooling method, and model version. The functional category is indicated by either a "K" for Keyswitch or "S" Standard (OEM) for OEM models. The next letter indicates the cooling method: "W" for water-cooled units, "A" for air-cooled lasers (where the customer must provide the proper cooling via fans or blowers). The last letter in the model number indicates the current model version "N". For example, the model number 60 KWN designates the ti-Series laser as a Keyswitch, water-cooled version N.

# Introduction

## Features & Nomenclature

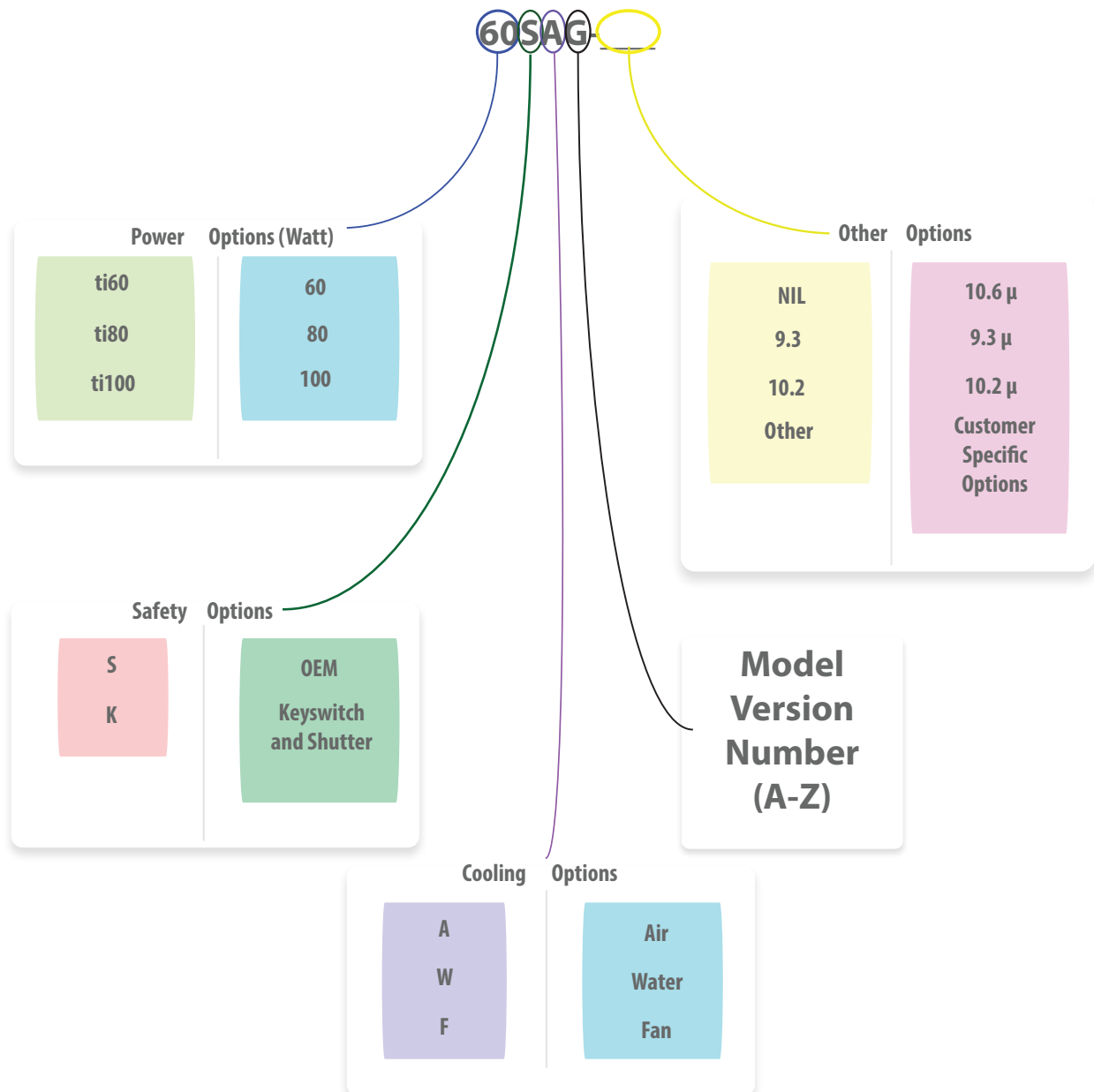

Figure 1-1 Anatomy of a model number.

# Operation

## 3

Use information in this chapter to familiarize yourself with ti-Series™ controls and indicators. Reference the Quick Start Guide for the initial startup process.

- Controls and indicators – displays and describes exterior controls and indicators on ti-Series Keyswitch and OEM lasers.
- Initial start-up – Reference the appropriate Quick Start Guide on our website [synrad.com/synrad/docroot/resources/libraries/quickstart](http://synrad.com/synrad/docroot/resources/libraries/quickstart) to learn how to start your ti-Series laser while verifying proper operation.

### **Warning** Serious personal injury



**Any** Class 4 laser product that emits **invisible** infrared laser radiation in the 9–11  $\mu\text{m}$  CO<sub>2</sub> wavelength band. CO<sub>2</sub> lasers emit an invisible beam that is capable of seriously burning human tissue.

**Because direct or diffuse laser radiation can inflict severe corneal injuries, always wear eye protection** when in the same area as an exposed laser beam.

**Do not allow the laser beam to contact a person!**

**This product emits an invisible laser beam that is capable of seriously burning human tissue.**

**Always be aware of the beam's path and always use a beam block while testing.**

### **Caution** Possible Equipment Damage



**Remove the aperture seal before firing the laser!**

**The self-adhesive seal is installed to prevent dust from entering the laser housing during shipment and installation** and must be removed before operation or damage will occur.

**During laser operation, use a gas purge to keep dust and vapor out of the beam path.**

**Applying PWM** Command pulses directly to the laser without first sending tickle pulses for at least two seconds will cause unpredictable laser emission, degrade optical rise time, and may lead to RF Driver failure

# Operation

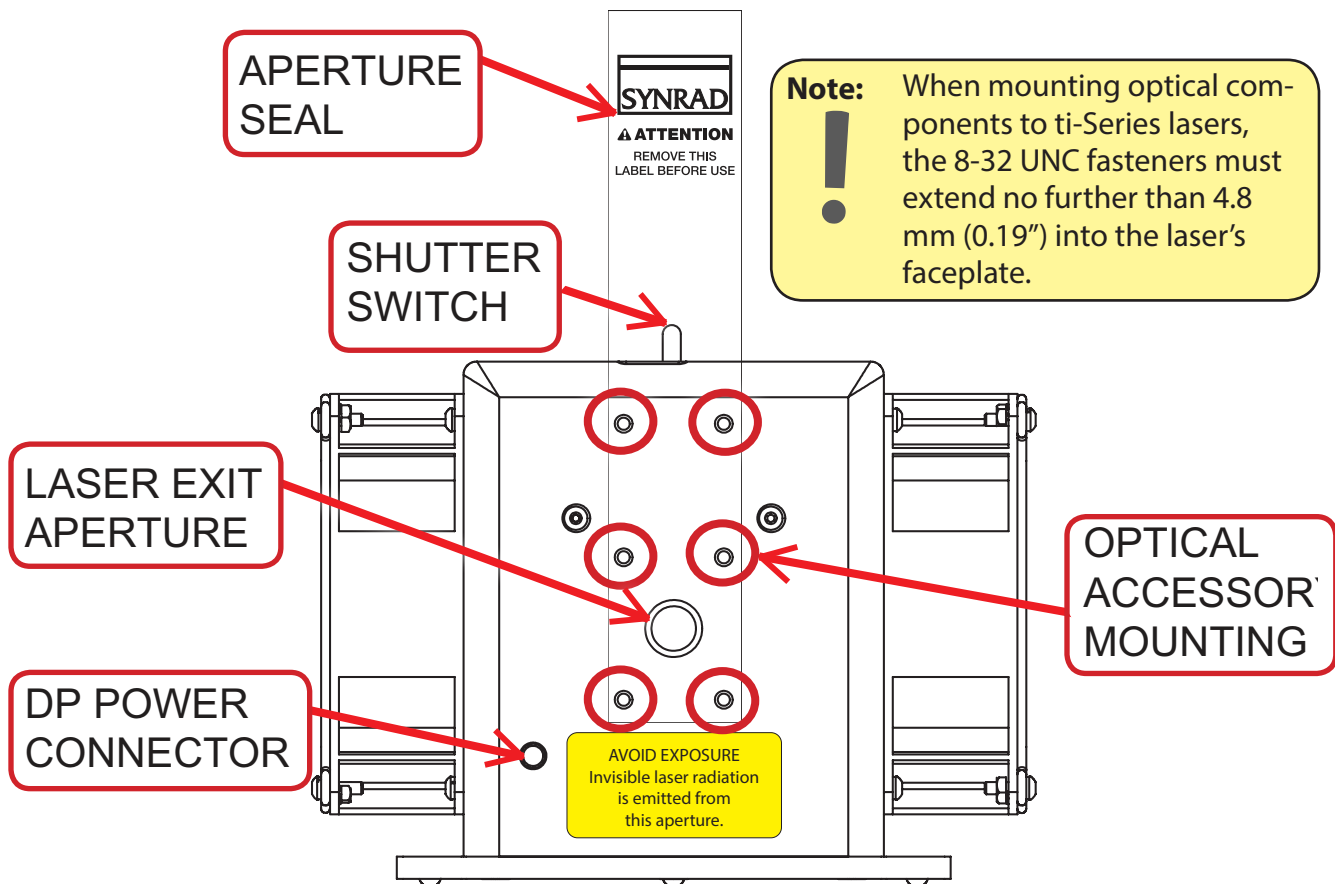

Figure 3-1 ti Series Front panel controls and indicators. (Fan-cooled ti60 shown).

## Controls and indicators

### ti-Series front panel

**Aperture Seal** – prevents dust from damaging the output coupler during shipping. Remove the red self-adhesive label before applying power to the laser.

**Shutter Switch (Keyswitch models only)** – manually closes the laser aperture and interrupts power to the RF section(s). Do not use the shutter to partially block the beam or to control output power.

**Laser Exit Aperture** – provides an opening from which the beam is emitted when lasing.

**Optical Accessory Mounting** – provides six threaded holes for mounting standard beam delivery components. When considering other components not specifically designed as Ti Series options, please consult the factory for restrictions since excessive weight may cause damage to the laser. To prevent damage to the laser when mounting optical components, the 8–32 mounting screws must not extend further than 4.8 mm (0.1875 in) into the laser faceplate.

**Diode Pointer (DP) Power Connector (Except SA models)** – provides a regulated +5 VDC, 50 mA output receptacle to power a visible red diode pointer (available from SYNRAD as an optional accessory).

SYNRAD® ti-Series™ Operator's Manual Version 2.5



# Operation

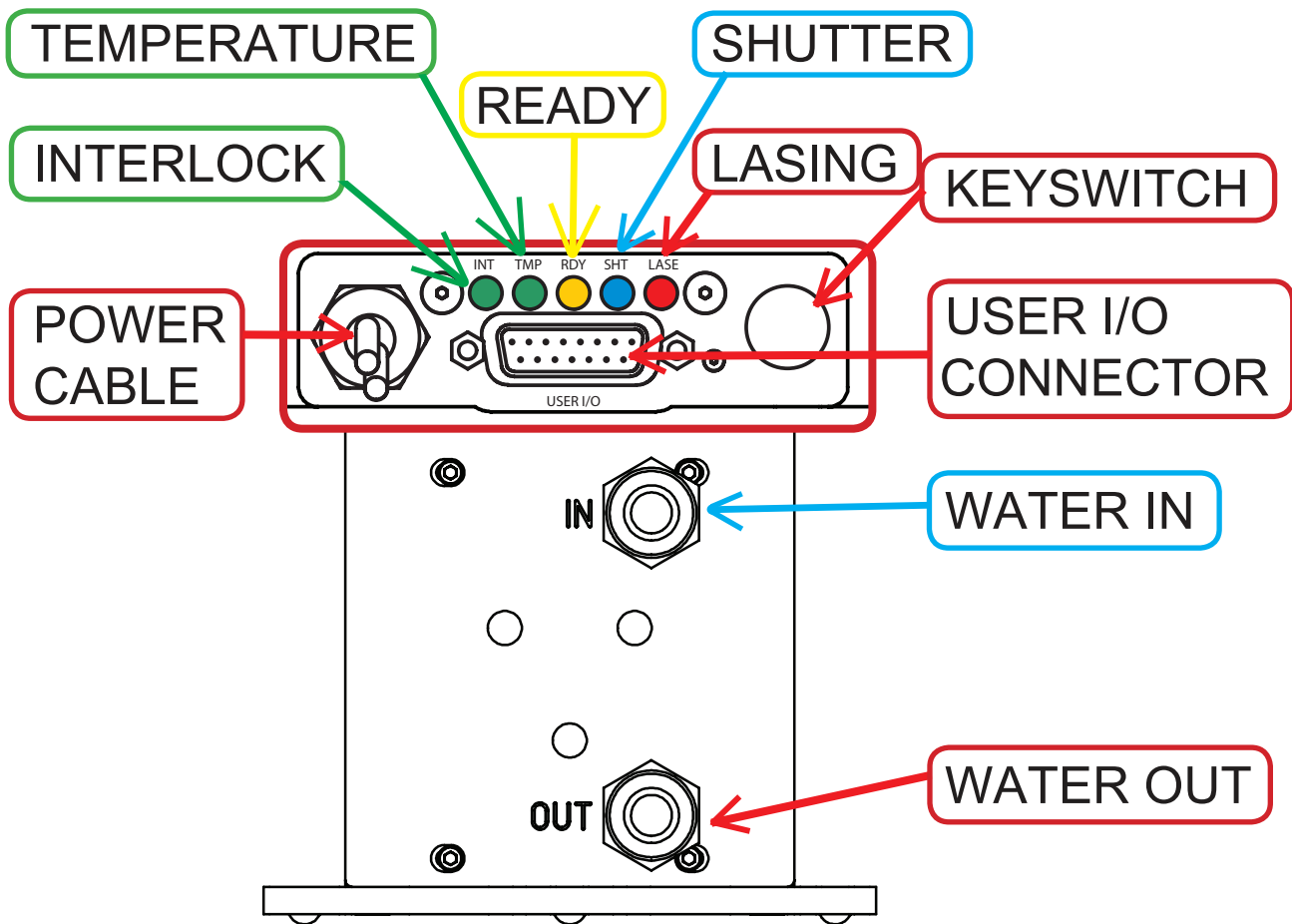

Figure 3-2 ti-Series Rear panel controls and indicators. (Water-cooled ti100 shown).

## ti-Series water-cooled rear panel

**DC Power Cables** – Receives +48 VDC from the DC power supply. Ti-Series DC power cables are manufactured from #10 AWG wire and measure 1 meter (42 inches) in length.

**INT (Remote Interlock) Indicator** – Illuminates green to indicate that a remote interlock circuit is closed and that lasing may be enabled (on Keyswitch lasers, a five-second delay occurs when the interlock circuit closes). The INT indicator is red and lasing is disabled if the interlock input is open.

**TMP (Temperature) Indicator** – Illuminates green to indicate that laser temperature is within limits and that lasing may be enabled. The TMP indicator is red and lasing is disabled if the laser's temperature rises above safe operating limits.

**RDY (Ready) Indicator** – Illuminates yellow when the laser is enabled, indicating that, after a five-second delay, lasing will begin when a PWM Command signal is applied.

# Operation

**SHT (Shutter) Indicator** – Illuminates blue to indicate that a Shutter Open Request signal is connected to the User I/O port and lasing may be enabled. On Keyswitch lasers, a five-second delay occurs when a Shutter Open Request signal is applied.

**LASE Indicator** – Illuminates red to indicate that the laser is actively lasing. The LASE indicator is off when tickle pulses are being generated and illuminates red when PWM Command signal pulses are long enough to produce laser output.

**Keyswitch (Keyswitch models only)** – Enables/disables operation of the laser. Laser is enabled when the Keyswitch is turned to the ON position. Turn the Keyswitch OFF to disable lasing.

**USER I/O Connector** – Provides a connection point for auxiliary output power as well as input and output signals. Refer to User I/O connections in the Technical Reference chapter for pin-outs and signal descriptions.

**WATER IN Port (water-cooled models only)** – Labeled IN, this connection provides the cooling water inlet to Laser's water-cooling system.

**WATER OUT Port (water-cooled models only)** – Labeled OUT, this connection provides the cooling water outlet to Laser's water-cooling system.

# Operation

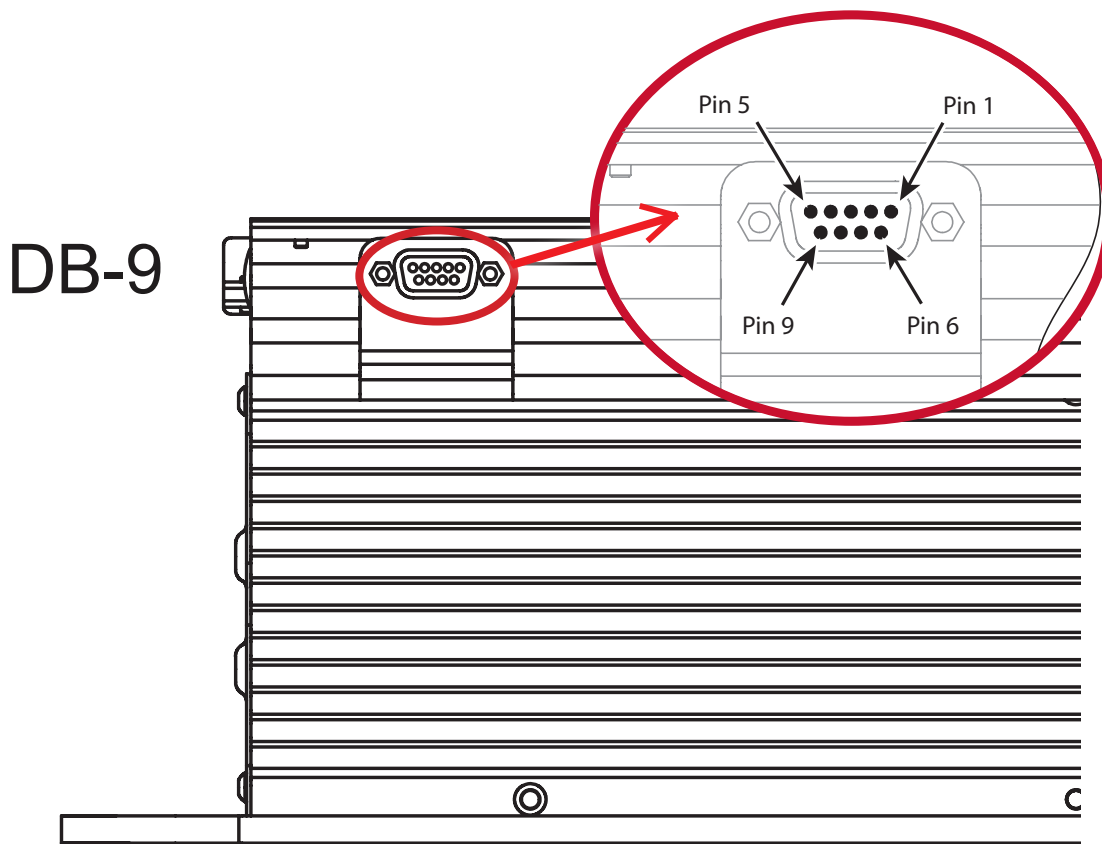

Figure 3-3 OEM ti-Series side panel controls and indicators. (Air-cooled ti60 OEM shown).

## ti-Series side panel (SA air-cooled Models Only)

DB-9 connector – provides an auxiliary +5 V power source as well as +48 VDC for powering 48 V cooling fans. The +5 VDC output is protected by a 0.5 A self-resetting fuse while both +48 VDC outputs are sourced directly from the user's 48 V DC power supply and protected by internal 1.1 A self-resetting fuses. Refer to DB-9 connections in the Technical Reference chapter for pinouts and signal descriptions.

**Note:** The pinout and functionality of the side-mounted DB-9 connector on the ti-Series SA model lasers is not the same as the DB-9 connector on t-Series (t70i SA model) lasers. See the Technical Reference Chapter in this Manual for details.

# Laser Safety

## 2

### Laser Safety

- Hazard Information – includes equipment label terms and hazards, please familiarize yourself with all definitions and their significance.
- General & Other Hazards – provides important information about the hazards and unsafe practices that could result in death, severe injury, or product damage.
- Disposal – information on your ti-Series laser parts and/or components as they pertain to disposal.
- Additional Safety Information – describes how to find additional information about your ti-Series™ laser.
- Compliance – explains in the subsections therein applicable and appropriate regulation information.

Note: Read the entire safety section. This will ensure you are familiar with the hazards and warnings prior to starting.

### Warning

#### Serious personal injury



This Class 4 CO<sub>2</sub> laser product emits invisible infrared laser radiation in the 9.3–10.6 μm wavelength band.

Because direct or diffuse laser radiation can inflict severe corneal injuries, always wear eye protection when in the same area as an exposed laser beam.

Do not allow the laser beam to contact a person!

This product emits an invisible laser beam that is capable of seriously burning human tissue.

Always be aware of the beam's path and always use a beam block while testing.

### Caution

#### Possible Equipment Damage



Ti-Series lasers MUST be provided with a pre-ionizing “tickle” signal during standby or laser “low” periods. This signal is automatically provided by SYNRAD® UC-2000 Universal Laser Controller or FH Series marking head. A tickle signal keeps the plasma ionized during laser “low” periods and facilitates plasma breakdown and pulse-to-pulse fidelity. Damage to or malfunction of the laser may occur if this, or equivalent drive signals are not provided.

# Laser Safety

## Hazard Information

Hazard information includes terms, symbols, and instructions used in this manual or on the equipment to alert both operating and service personnel to the recommended precautions in the care, use, and handling of Class 4 laser equipment.

## Terms

Certain terms are used throughout this manual or on the equipment labels. Please familiarize yourself with their definitions and significance.









Parameter	Description
 	<p><b>WARNING:</b> Potential &amp; Imminent hazards which, if not avoided, could result in death or serious injury.</p> <p>Alerts operator of serious dangers, hazardous radiation, hazardous voltages, vapor hazard, &amp; reflective dangers.</p>
	<p><b>DANGER:</b> Hazards which, if not avoided, could result in minor or moderate injury.</p> <p>Alerts operator of lifting dangers.</p>
	<p><b>CAUTION:</b> Potential hazards or unsafe practices which, if not avoided, may result in product damage.</p> <p>Alerts operator of equipment dangers.</p>
<p>Important Note: </p> <p>Note: </p> <p>Tip: </p>	<p><b>IMPORTANT NOTES &amp; TIPS:</b></p> <p>Content specific information and/or recommendations.</p>

Figure 2-1 Labeling terms and definitions.

**Warning**  
**Serious personal injury**

For laser systems being used or sold within the U.S.A., customers should refer to and follow the laser safety precautions described American National Standards Institute (ANSI) document Z136.1-2007, *Safe Use of Lasers*.

For laser systems being used or sold outside the U.S.A., customers should refer to and follow the laser safety precautions described in European Normative and International Electrotechnical Commission documents IEC/ TR 60825-14:2004, *Safety of Laser Products – Part 14: A User’s Guide*.

# Laser Safety

## General hazards

Following are descriptions of general hazards and unsafe practices that could result in death, severe injury, or product damage. Specific warnings and cautions not appearing in this section are found throughout the manual.

### **Warning**

**Serious  
personal  
injury**



**Do not allow laser radiation to enter the eye** by viewing direct or reflected laser energy.

**CO<sub>2</sub> laser radiation can be reflected from metallic objects** even though the surface is darkened. Direct or diffuse laser radiation can inflict severe corneal injuries leading to permanent eye damage or blindness. All personnel must wear eye protection suitable for CO<sub>2</sub> radiation, e.g. 9.3–10.6 μm when in the same area as an exposed laser beam.

**Eye wear protects against scattered energy** but is not intended to protect against direct viewing of the beam—never look directly into the laser output aperture or view scattered laser reflections from metallic surfaces.

**Enclose the beam path whenever possible. Exposure to direct or diffuse CO<sub>2</sub> laser radiation can seriously burn human or animal tissue, which may cause permanent damage.**

**This product is not intended for use in explosive, or potentially explosive, atmospheres!**

**Materials processing with a laser can generate air contaminants such as vapors, fumes, and/or particles that may be noxious, toxic, or even fatal. Material Safety Data Sheets (MSDS) for materials being processed should be thoroughly evaluated and the adequacy of provisions for fume extraction, filtering, and venting should be carefully considered. Review the following references for further information on exposure criteria:**

**ANSI Z136.1-2007, Safe Use of Lasers, section 7.3.**

**U.S. Government's Code of Federal Regulations: 29 CFR 1910, Subpart Z.**

**Threshold Limit Values (TLV's) published by the American Conference of Governmental Industrial Hygienists (ACGIH).**

**It may be necessary to consult with local governmental agencies regarding restrictions on the venting of processing vapors.**

**The use of aerosol dusters containing difluoroethane causes "blooming", a condition that significantly expands and scatters the laser beam. This beam expansion can effect mode quality and/or cause laser energy to extend beyond the confines of optical elements in the system, possibly damaging acrylic safety shielding. Do not use air dusters containing difluoroethane in any area adjacent to CO<sub>2</sub> laser systems because difluoroethane persists for long time periods over wide areas.**

# Laser Safety

## General hazards (Continued)

Ti-Series™ lasers should be installed and operated in manufacturing or laboratory facilities by trained personnel only. Due to the considerable risks and hazards associated with the installation and operational use of any equipment incorporating a laser, the operator must follow product warning labels and instructions to the user regarding laser safety. To prevent exposure to direct or scattered laser radiation, follow all safety precautions specified throughout this manual and exercise safe operating practices per ANSI Z136.1-2014, Safe Use of Lasers at all times when actively lasing.

Due to the specific properties of laser light, a unique set of safety hazards that differ from other light sources must be considered. Just like light, lasers can be reflected, refracted, diffracted or scattered.

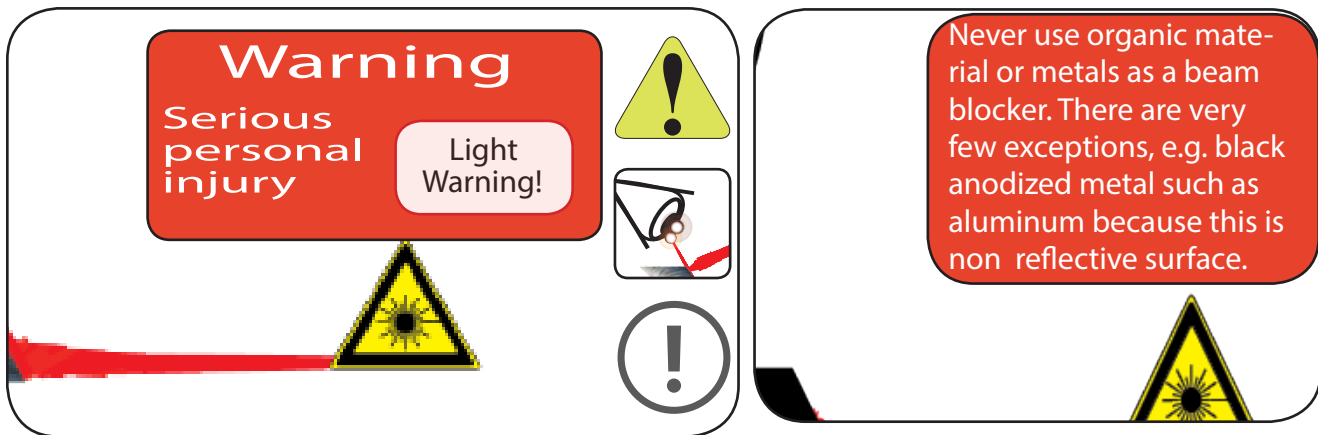

Figure 2-2 Always wear safety glasses or protective goggles with side shields to reduce the risk of damage to the eyes when operating the laser.

A CO<sub>2</sub> laser is an intense energy source and will ignite most materials under the proper conditions. Never operate the laser in the presence of flammable or explosive materials, gases, liquids, or vapors.



Safe operation of the laser requires the use of an external beam block to safely block the beam from traveling beyond the desired work area. Do not place your body or any combustible object in the path of the laser beam. Use a water-cooled beam dump or power meter, or similar non-scattering, noncombustible material as the beam block. Never use organic material or metals as the beam blocker; organic materials, in general, are apt to combust or melt and metals act as specular reflectors which may create a serious hazard outside the immediate work area.

Always wear safety glasses or protective goggles with side shields to reduce the risk of damage to the eyes when operating the laser.

# Laser Safety

## Other hazards

The following hazards are typical for this product family when incorporated for intended use: (A) risk of injury when lifting or moving the unit; (B) risk of exposure to hazardous laser energy through unauthorized removal of access panels, doors, or protective barriers; (C) risk of exposure to hazardous laser energy and injury due to failure of personnel to use proper eye protection and/or failure to adhere to applicable laser safety procedures; (D) risk of exposure to hazardous or lethal voltages through unauthorized removal of covers, doors, or access panels; (E) generation of hazardous air contaminants that may be noxious, toxic, or even fatal.

## Disposal

This product contains components that are considered hazardous industrial waste. If a situation occurs where the laser is rendered non-functional and cannot be repaired, it may be returned to SYNRAD® who, for a fee, will ensure adequate disassembly, recycling and/or disposal of the product.

## Additional laser safety information

The SYNRAD web site (<http://www.synrad.com/LaserFacts/safetyinfo.html>) contains an online laser safety handbook that provides information on (1) Laser Safety Standards for OEM's/System Integrators, (2) Laser Safety Standards for End Users, (3) References and Sources, and (4) Assistance with Requirements.

In addition, the Occupational Safety and Health Administration (OSHA) provides an online Technical Manual (located at [http://www.osha.gov/dts/osta/otm/otm\\_iii/otm\\_iii\\_6.html](http://www.osha.gov/dts/osta/otm/otm_iii/otm_iii_6.html)). Section III, Chapter 6 and Appendix III are good resources for laser safety information. Another excellent laser safety resource is the Laser Institute of America (LIA). Their comprehensive web site is located at <http://www.lia.org>.



# Laser Safety

## Ti60 label locations

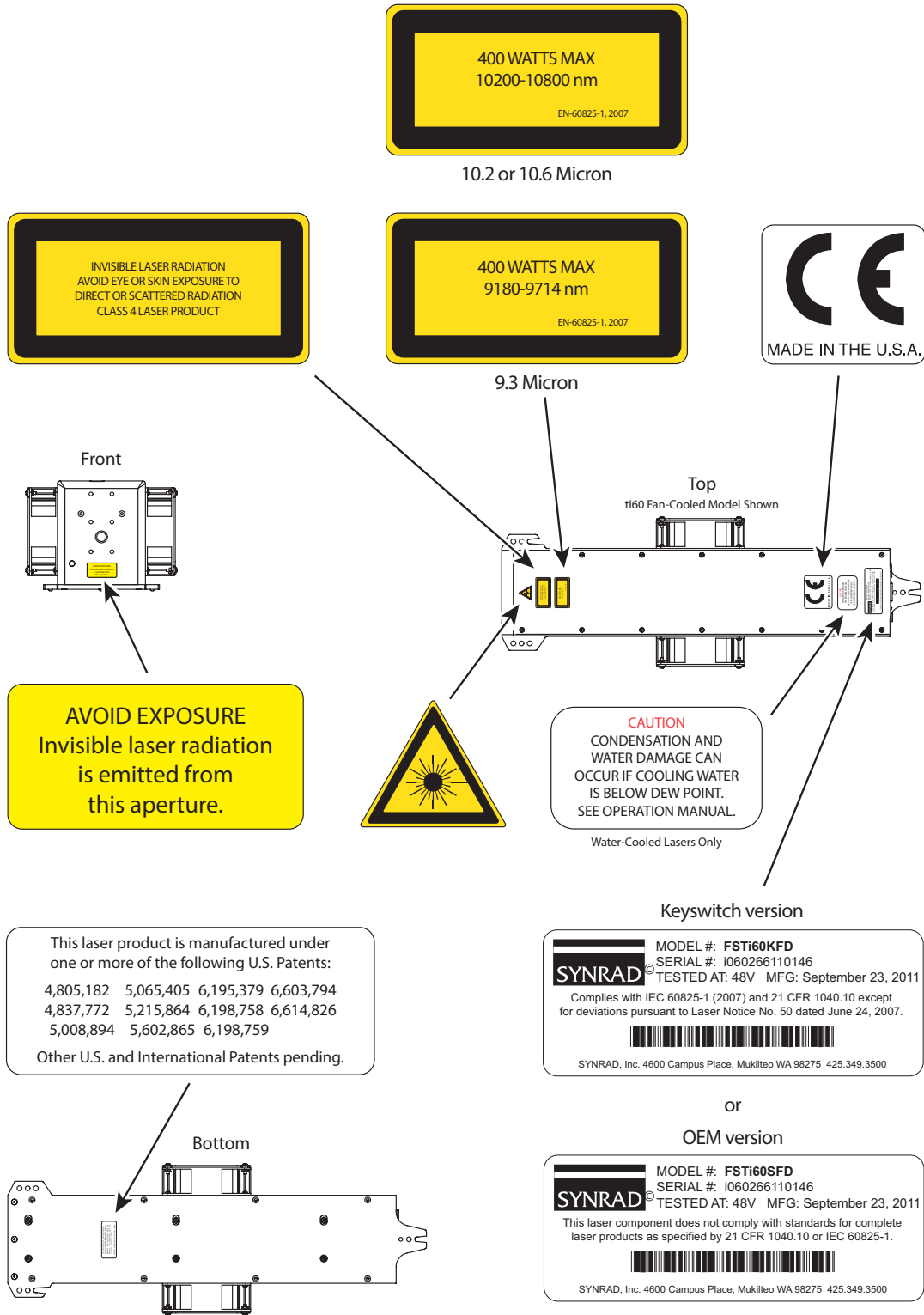

Figure 2-3 Ti60 hazard label locations.

# Laser Safety

## Ti80 label locations

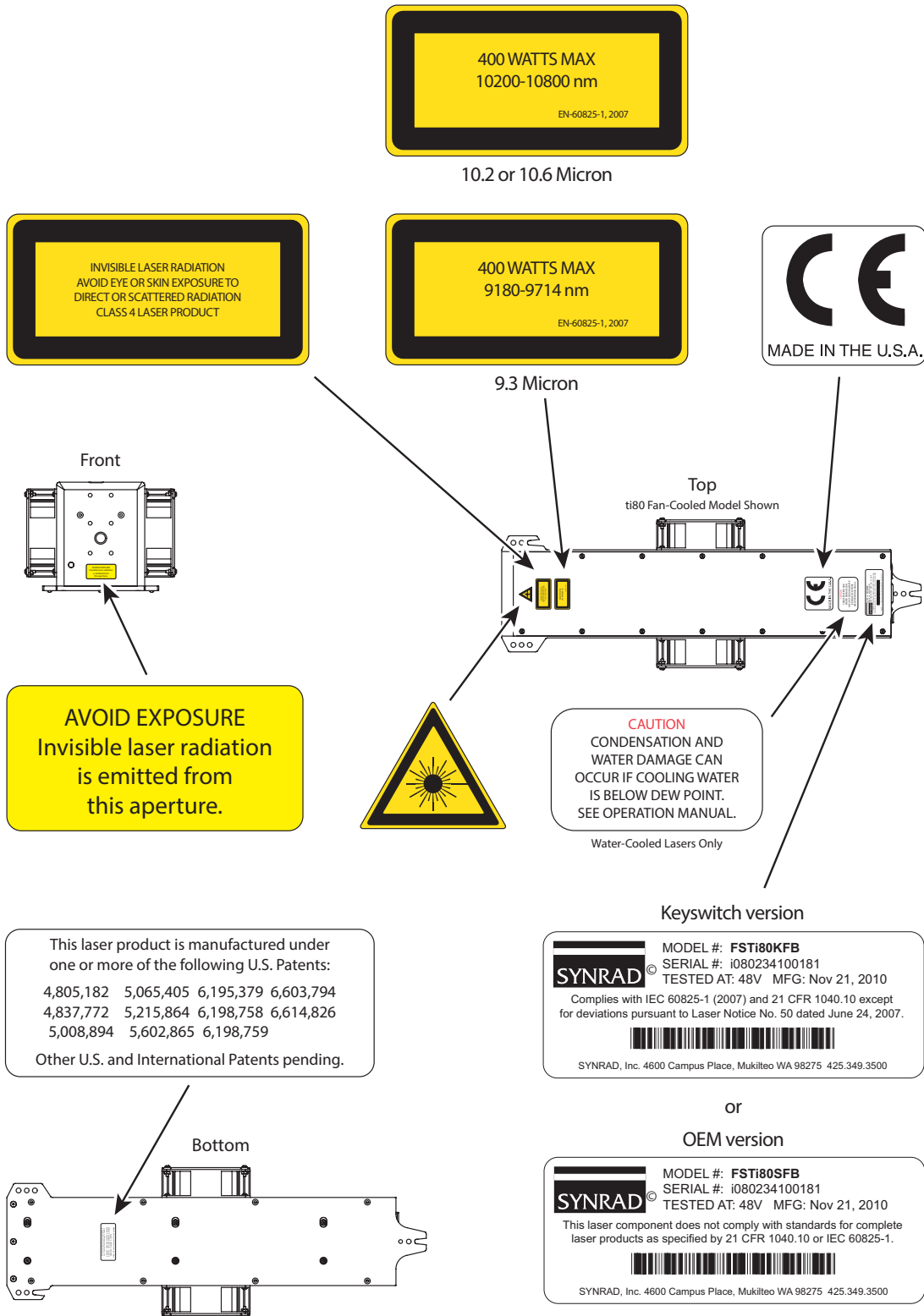

Figure 2-4 Ti80 hazard label locations.

# Laser Safety

## Ti100 label locations

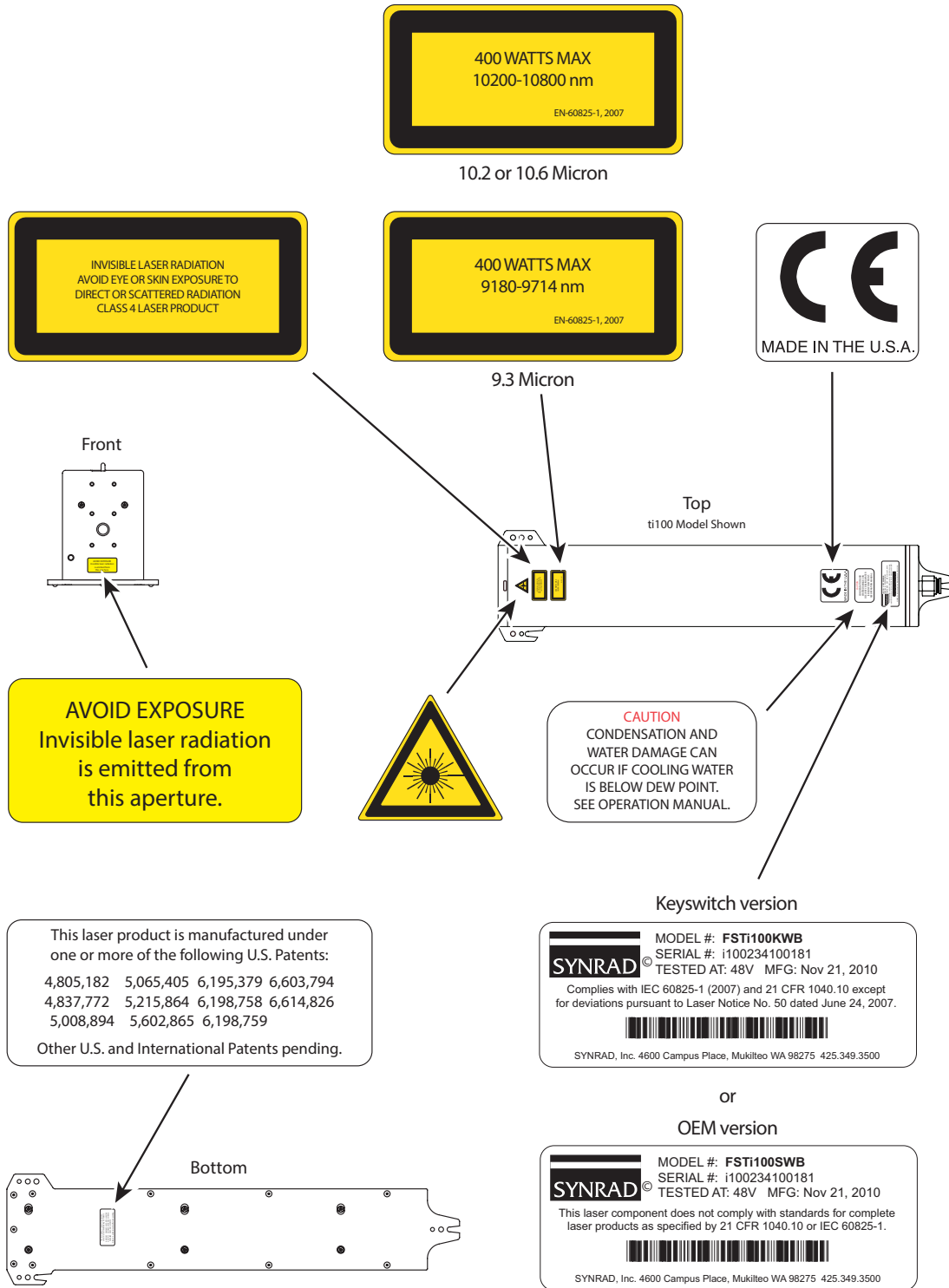

Figure 2-5 Ti100 hazard label locations.

# Laser Safety

## Compliance

- Center for Devices and Radiological Health (CDRH) requirements.
- Federal Communications Commission (FCC) requirements.
- European Union (EU) requirements.

SYNRAD® lasers are designed, tested, and certified to comply with certain United States (U.S.) and European Union (EU) regulations. These regulations impose product performance requirements related to electromagnetic compatibility (EMC) and product safety characteristics for industrial, scientific, and medical (ISM) equipment. The specific provisions to which systems containing Ti-Series lasers must comply are identified and described in the following paragraphs. Note that compliance to CDRH, FCC, and EU requirements depends in part on the laser version selected—Keyswitch or OEM.

In the U.S., laser safety requirements are governed by the Center for Devices and Radiological Health (CDRH) under the auspices of the U.S. Food and Drug Administration (FDA) while radiated emission standards fall under the jurisdiction of the U.S. Federal Communications Commission (FCC). Outside the U.S., laser safety and emissions are governed by European Union (EU) Directives and Standards.

In the matter of CE-compliant laser products, SYNRAD assumes no responsibility for the compliance of the system into which the product is integrated, other than to supply and/or recommend laser components that are CE marked for compliance with applicable European Union Directives.

Because OEM laser products are intended for incorporation as components in a laser processing system, they do not meet all of the Standards for complete laser processing systems as specified by 21 CFR, Part 1040 or EN 60825-1. SYNRAD assumes no responsibility for the compliance of the system into which OEM laser products are integrated.

## Center for Devices and Radiological Health (CDRH) requirements

Product features incorporated into the design of Ti-Series™ lasers to comply with CDRH requirements are integrated as panel controls or indicators, internal circuit elements, or input/output signal interfaces. Specifically, these features include a laser and laser ready indicators, remote interlock for power on/off, a laser aperture shutter switch, and a five-second delay between power on and lasing. Incorporation of certain features is dependent on the laser version (Keyswitch or OEM). Table 1, Class 4 safety features, indicates which features are available on Ti-Series lasers, the type and description of the feature, and if the feature is required by CDRH regulations.

### OEM models

Ti-Series OEM lasers are OEM products intended for incorporation as components in laser processing systems. As supplied by SYNRAD, these lasers do not meet the requirements of 21 CFR, Subchapter J without additional safeguards. In the U.S., the Buyer of these OEM laser components is solely responsible for the assurance that the laser processing system sold to an end user complies with all laser safety requirements before the actual sale of the system. Under CDRH regulations, the Buyer must submit a report to the CDRH prior to shipping the system. In jurisdictions outside the U.S., it is the sole responsibility of the Buyer of these OEM

# Laser Safety

Under CDRH regulations, the Buyer must submit a report to the CDRH prior to shipping the system. In jurisdictions outside the U.S., it is the sole responsibility of the Buyer of these OEM components to ensure that they meet all applicable local laser safety requirements. In cases where the Buyer is also the end-user of the OEM laser product, the Buyer/end-user must integrate the laser so that it complies with all applicable laser safety standards as set forth above.

## Federal Communications Commission (FCC) Requirements

The United States Communication Act of 1934 vested the Federal Communications Commission (FCC) with the authority to regulate equipment that emits electromagnetic radiation in the radio frequency spectrum. The purpose of the Communication Act is to prevent harmful electromagnetic interference (EMI) from affecting authorized radio communication services. The FCC regulations that govern industrial, scientific, and medical (ISM) equipment are fully described in 47 CFR, Part 18, Subpart C.

SYNRAD® ti Series lasers have been tested and found to comply by demonstrating performance characteristics that have met or exceeded the requirements of 47 CFR, Part 18, Radiated and Conducted Emissions.

**Note:** The following FCC information to the user is provided to comply with the requirements of 47 CFR, Part 18, Section 213.

### FCC information to the user

#### Interference Potential

In our testing, SYNRAD, has not discovered any significant electrical interference traceable to ti Series lasers.

#### System Maintenance

Ensure that all exterior covers are properly fastened in position.

#### Measures to Correct Interference

If you suspect that your laser interferes with other equipment, take the following steps to minimize this interference:

- 1 Use shielded cables to and from the equipment that is experiencing interference problems.
- 2 Ensure that the laser is properly grounded to the same electrical potential as the equipment or system it is connected to.

### FCC caution to the user

The Federal Communications Commission warns the user that changes or modifications of the unit not expressly approved by the party responsible for compliance could void the user's authority to operate the equipment.

# Laser Safety

## European Union (EU) requirements

### RoHS compliance

SYNRAD ti-Series lasers meet the requirements of the European Parliament and Council Directive 2014/65/EU on the Restriction of the Use of Certain Hazardous Substances in Electrical and Electronic Equipment that establishes maximum concentration values for certain hazardous substances in electrical and electronic equipment.

### Laser safety standards

Under the Low Voltage Directive, 2014/35/EC, the European Norm (EN) document EN 60825-1:2014 was developed to provide laser safety guidance and includes clauses on Engineering Specifications, Labeling, Other Informational Requirements, Additional Requirements for Specific Laser Products, Classification, and Determination of the Accessible Emission Level. To develop a risk assessment plan/laser safety program for users, see IEC/TR 60825-14:2004 that includes clauses on Administrative Policies, Laser Radiation Hazards, Determining the MPE, Associated Hazards, Evaluating Risk, Control Measures, Maintenance of Safe Operation, Incident Reporting and Accident Investigation, and Medical Surveillance.

### OEM models

Ti-Series OEM lasers are OEM products intended for incorporation as components in laser processing systems. As supplied by SYNRAD®, these lasers do not meet the requirements of EN 60825-1 without additional safeguards. European Union Directives state that “OEM laser products which are sold to other manufacturers for use as components of any system for subsequent sale are not subject to this Standard, since the final product will itself be subject to the Standard.” This means that Buyers of OEM laser components are solely responsible for the assurance that the laser processing system sold to an end-user complies with all laser safety requirements before the actual sale of the system. Note that when an OEM laser component is incorporated into another device or system, the entire machinery installation may be required to conform to EN 60825-1; EN 60204-1:2006, Safety of Machinery; the Machinery Directive, EN 2006/42/EC; and/or any other applicable Standards and in cases where the system is being imported into the U.S., it must also comply with CDRH regulations.

In cases where the Buyer is also the end-user of the OEM laser product, the Buyer/end-user must integrate the laser so that it complies with all applicable laser safety standards as set forth above. Table 1, Class 4 safety features, summarizes Ti-Series product features, indicating the type and description of features and whether those features are required by European Union regulations.

### Electromagnetic interference standards

The European Union’s Electromagnetic Compatibility (EMC) Directive, 2004/108/EC, is the sole Directive developed to address electromagnetic interference (EMI) issues in electronic equipment. In particular, the Directive calls out European Norm (EN) documents that define the emission and immunity standards for specific product categories. For ti-Series lasers, EN 61000-6-4 defines radiated and conducted RF emission limits while EN 61000-6-2 defines immunity requirements for industrial environments.

SYNRAD ti-Series lasers have demonstrated performance characteristics that have met or exceeded the requirements of EMC Directive 2014/30/EU.

# Laser Safety

Table 2-1 Class 4 safety features.

Feature	Location / Description	Required by:		Available on:
		CDRH	EN60825-1	OEM Ti-Series
Keyswitch <sup>1</sup>	Rear panel control On/Off/Reset Keyswitch controls power to laser electronics. Key cannot be removed from switch in the "On" position.	Yes	Yes	No
Shutter function	Laser control Functions as a beam attenuator to disable RF driver/laser output when closed.	Yes	Yes	Yes
Shutter indicator	Rear panel indicator (Blue) Illuminates blue to indicate shutter is open.	No	No	Yes
Ready indicator <sup>2</sup>	Rear panel indicator (Yellow) Indicates that laser has power applied and is capable of lasing.	Yes	Yes	Yes
Lase indicator	Rear panel indicator (Red) Indicates that is actively lasing. Lase LED illuminates when the duty cycle of the Command signal is long enough to produce laser output.	No	No	Yes
Five second delay	circuit element Disables RF driver/laser output for five seconds after Keyswitch is turned to "On" or remote reset/start pulse is applied when Keyswitch is in "On" position.	Yes	No	Yes
Power fail lockout <sup>1</sup>	circuit element Disables RF driver/laser output if input power is removed then later reapplied (AC power failure or remote interlock actuation) while Keyswitch is in "On" position.	Yes	Yes	No
Remote Interlock	Rear panel connection Disables RF driver/laser output when a remote interlock switch on an equipment door or panel is opened.	Yes	Yes	Yes
Remote Interlock	Rear panel indicator (Green/Red) Illuminates green when Remote Interlock circuitry is closed indicator Illuminates red when interlock circuitry is open.	No	No	Yes
Over temperature	circuit element Temperature shutdown occurs if temperature of the laser protection tube rises above safe operating limits.	No	No	Yes
Temp indicator	Rear panel indicator (Green/Red) Illuminates green when laser temperature is within operating limits, changing to red when thermal limits are exceeded.	No	No	Yes
Warning labels	Ti-Series exterior Labels attached to various external housing locations to warn personnel of potential laser hazards.	Yes	Yes	Yes

1 Keyswitch lasers only.

2 On OEM versions, the Power indicator illuminates and the five (5) second delay begins when DC power is applied to the laser.

# Laser Safety

When integrating SYNRAD®'s ti-Series™ OEM lasers, the Buyer and/or integrator of the end system is responsible for meeting all applicable Standards to obtain the CE mark. To aid this compliance process, SYNRAD testing program has demonstrated that Ti-Series lasers comply with the relevant requirements of 2014/30/EU, the Electromagnetic Compatibility Directive, as summarized in the table below.

Table 2-2 European Union Directives.

## Applicable Standards / Norms

2014/30/EU	Electromagnetic Compatibility Directive
2006/95/EC	Low Voltage Directive
2015/863/EU	RoHS Directive
EN 61010-1	Safety Requirements for Electrical Equipment for Measurement, Control, and Laboratory Use - Part 1: General Requirements
EN 61000-6-4:2007	Radiated Emissions Group 1, Class A
EN 61000-6-4:2007	Conducted Emissions Group 1, Class A
EN 61000-6-2:2005	Electrostatic Discharge Immunity
EN 61000-6-2:2005	RF Electromagnetic Field Immunity
EN 61000-6-2:2005	Electrical Fast Transient/Burst Immunity
EN 61000-6-2:2005	Conducted RF Disturbances Immunity

After a laser or laser processing system has met the requirements of all applicable EU Directives, the product can bear the official compliance mark of the European Union as a Declaration of Conformity.

After a laser or laser processing system has met the requirements of all applicable EU Directives, the product can bear the official compliance mark of the European Union as shown in the figure below and a Declaration of Conformity is provided for the compliant component.



# Laser Safety

## Declaration of Conformity

in accordance with ISO / IEC 17050-2:2004

We,

**Manufacturer's Name:** SYNRAD® A Novanta® Company

**Manufacturer's Address:** 4600 Campus Place  
Mukilteo, WA 98275 U.S.A.

Hereby declare under our sole responsibility that the following equipment:

**Product Name:** Firestar™ ti-Series Laser

**Model Number:** FSti60KxH, KxG (Keyswitch)  
FSti60SxH, SxG (\*OEM)

Conforms to the following Directive(s) and Standard(s):

**Applicable Directive(s):** 2014/30/EU Electromagnetic Compatibility Directive  
2014/35/EU Low Voltage Directive  
(EU) 2015/863 RoHS Directive

**Applicable Standard(s):**

EN 61010-1:2010 Safety Requirements for Electrical Equipment for Measurement, Control, and Laboratory Use - Part 1: General Requirements  
EN 60825-1-4:2014 Safety of Laser Products (Keyswitch only)  
EN 61000-6-4:2007 Radiated Emissions, Group 1, Class A  
EN 61000-6-4:2007 Conducted Emissions, Group 1, Class A  
EN 61000-6-2:2005 Electrostatic Discharge Immunity  
EN 61000-6-2:2005 RF Electronic Fields Immunity  
EN 61000-6-2:2005 Electrical Fast Transient/Burst Immunity  
EN 61000-6-2:2005 Conducted RF Disturbances Immunity

\*OEM lasers do not comply with EN 60825-1:2014, *Safety of Laser Products*. Buyers of OEM laser products are solely responsible for meeting applicable Directives and Standards for CE compliance and marking.

**Corporate Officer:**



Tim Freni, Quality Manager of SYNRAD

**European Contact:**

Novanta Distribution (USD) GmbH  
Parkring 57-59  
85748 Garching bei München, Germany

Dated: 7/22/19



MADE IN THE U.S.A.  
900-20976-01 Rev D

Figure 2-7 ti60 Declaration Document.

# Laser Safety

## Declaration of Conformity

in accordance with ISO / IEC 17050-2:2004

We,

**Manufacturer's Name:** SYNRAD® A ®Novanta Company

**Manufacturer's Address:** 4600 Campus Place  
Mukilteo, WA 98275 U.S.A.

Hereby declare under our sole responsibility that the following equipment:

**Product Name:** Firestar™ ti-Series Laser

**Model Number:** FSti80KxC, KxD (Keyswitch)  
FSti80SxC, SxD (\*OEM)

Conforms to the following Directive(s) and Standard(s):

<b>Applicable Directive(s):</b>	2014/30/EU	Electromagnetic Compatibility Directive
	2014/35/EU	Low Voltage Directive
	(EU) 2015/863	RoHS Directive

**Applicable Standard(s):**

EN 61010-1:2010	Safety Requirements for Electrical Equipment for Measurement, Control, and Laboratory Use - Part 1: General Requirements
EN 60825-1-4:2014	Safety of Laser Products (Keyswitch only)
EN 61000-6-4:2007	Radiated Emissions, Group 1, Class A
EN 61000-6-4:2007	Conducted Emissions, Group 1, Class A
EN 61000-6-2:2005	Electrostatic Discharge Immunity
EN 61000-6-2:2005	RF Electronic Fields Immunity
EN 61000-6-2:2005	Electrical Fast Transient/burst Immunity
EN 61000-6-2:2005	Conducted RF Disturbances Immunity

\*OEM lasers do not comply with EN 60825-1:2014, *Safety of Laser Products*. Buyers of OEM laser products are solely responsible for meeting applicable Directives and Standards for CE compliance and marking.

**Corporate Officer:**

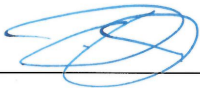

Tim Freni, Quality Manager of SYNRAD

**European Contact:**

Novanta Distribution (USD) GmbH  
Parking 57-59  
85748 Garching bei München, Germany

Date: 7/22/19



MADE IN THE U.S.A.  
900-20976-15 Rev D

Figure 2-8 ti80 Declaration document.

# Laser Safety

## Declaration of Conformity

in accordance with ISO / IEC 17050-2:2004

We,

**Manufacturer's Name:** SYNRAD® A ®Novanta Company

**Manufacturer's Address:** 4600 Campus Place  
Mukilteo, WA 98275 U.S.A.

Hereby declare under our sole responsibility that the following equipment:

**Product Name:** Firestar™ ti-Series Laser

**Model Number:** FSti100KWC, KFB (Keyswitch)  
FSti100SxB, SxC (\*OEM)

Conforms to the following Directive(s) and Standard(s):

<b>Applicable Directive(s):</b>	2014/30/EU	Electromagnetic Compatibility Directive
	2014/35/EU	Low Voltage Directive
	(EU) 2015/863	RoHS Directive

**Applicable Standard(s):**

EN 61010-1:2010	Safety Requirements for Electrical Equipment for Measurement, Control, and Laboratory Use - Part 1: General Requirements
EN 60825-1-4:2014	Safety of Laser Products (Keyswitch only)
EN 61000-6-4:2007	Radiated Emissions, Group 1, Class A
EN 61000-6-4:2007	Conducted Emissions, Group 1, Class A
EN 61000-6-2:2005	Electrostatic Discharge Immunity
EN 61000-6-2:2005	RF Electronic Fields Immunity
EN 61000-6-2:2005	Electrical Fast Transient/burst Immunity
EN 61000-6-2:2005	Conducted RF Disturbances Immunity

\*OEM lasers do not comply with EN 60825-1:2014, *Safety of Laser Products*. Buyers of OEM laser products are solely responsible for meeting applicable Directives and Standards for CE compliance and marking.

**Corporate Officer:**



Tim Freni, Quality Manager of SYNRAD

**European Contact:**

Novanta Distribution (USD) GmbH  
Parkring 57-59  
85748 Garching bei München, Germany

Date: 7/22/19



MADE IN THE U.S.A.  
900-20976-11 Rev C

Figure 2-9 ti00 Declaration document.

# Technical Reference

## 4

### Technical reference summary

- Technical overview – briefly describes ti-Series technology and basic optics.
- Controlling laser power – explains various aspects of the ti-Series control signals, optics, assist gas specifications, & cooling basics.
- Control signals & operating modes – describes controlling signals and operation modes for the laser.
- User I/O connections – describes user input/output (I/O) signals including DB-9 (SA models Only).
- DB-9 pin descriptions, 48 VDC fan – describes DB-9 pin-outs, fan speed control & connections.
- Integrating safety features – provides information on keyswitch, remote interlock, & shutter functions for the ti-Series laser.
- Ti-Series general specifications – provides specifications for the ti-Series laser.
- Ti-Series outline, mounting, & packaging diagrams – includes the ti-Series drawings.

#### **Caution** Possible Equipment Damage



Because of their smaller beam diameter, ti-Series lasers have significantly higher power densities than other SYNRAD lasers. This means that any contaminants on the laser's output coupler (or on any beam delivery optic) can absorb enough energy to damage one or more optics in the beam path.

Any amount of contaminants on the laser's output window (or on any optic in the beam path) can absorb enough energy to damage the optic.

Periodically inspect all beam delivery optics for signs of contaminants and carefully clean as required.

In dirty environments, purge laser optics using filtered air or nitrogen to prevent & purge vapor and/or debris from accumulating on optical surfaces. Contact SYNRAD for recommendations.

### Technical overview

- Introduction
- ti-Series laser tube
- Optical resonator
- Control circuitry & internal RF supply
- Optical setup, beam delivery, focusing optics & assist gas specifications
- Cooling

### Introduction

SYNRAD commitment to continuous improvement resulting in an even more reliable product with the same high performance standard for which the ti-Series™ is renown. SYNRAD introduces a high-stability (HS) version of the ti-series lasers (output power in the range of 60-100W) with excellent power stability & pulsing characteristics, exceptional beam quality, and proven fast rise/fall time features for your high-speed precision processing needs.

Ti-series lasers incorporate the latest technology in sealed carbon dioxide devices. SYNRAD combines the best features based on a combination of free-space and waveguide resonator designs that enable CO<sub>2</sub> laser technology to economically produce a symmetrical beam from both a small and powerful laser capable of many years of operation with virtually no maintenance.

Your ti-series laser's unique, extruded aluminum envelope features the ruggedness, stable optical support, long gas life, excellent heat transfer, and low operating costs in contrast to other laser tube technologies. In addition to being the vessel that maintains the lasing environment, the aluminum tube is also the structural platform that integrates the laser's optical, electrical, and cooling components.

### Ti-Series Laser tube

Ti-Series lasers were developed using new technology patented by SYNRAD. Ti-series patented "t" technology, based on a combination of free-space and waveguide resonator designs, enables SYNRAD to economically produce a symmetrical laser beam from a small but powerful laser capable of operating for many years with virtually no maintenance. Ti-series unique extruded aluminum envelope offers excellent heat transfer, long gas life, and low operating costs in contrast to other laser tube technologies. In addition to being the vessel that maintains the lasing environment, the aluminum tube is also the structural platform that integrates the laser's optical, electrical, and cooling components.

### Optical resonator

The optical resonator, in conjunction with the electrodes and the gas mixture, generates the laser beam. Ti-Series optical resonators are comprised of three optical elements: a front mirror, a rear mirror, and an output window. These optical elements are fastened to the tube's exterior and are exposed to its interior through holes in the end caps. O-rings are sandwiched

# Technical Reference

## Technical Overview

between optical elements and the end cap to form a gas seal and to provide a flexible cushion that allows the slight movement necessary for alignment. All optical elements are aligned and locked into place by factory technicians before the laser is shipped.

The output beam, roughly circular as it exits the resonator, transitions to a Gaussian-like mode in five to ten Raleigh ranges, which is approximately 1.6–3.3 m (5.2–10.8 ft). The internal structure and optics of the resonator combine to produce a Gaussian-like mode quality ( $M^2$  factor) of  $< 1.2^*$ . As shown in Figure 3-1, beam waist diameter is 2.0 mm  $\pm 0.3$  mm at the output aperture and full angle divergence due to diffraction is less than 7 milliradians (a 7 mrad full angle divergence means that beam diameter increases 7 mm over every one meter distance traveled).

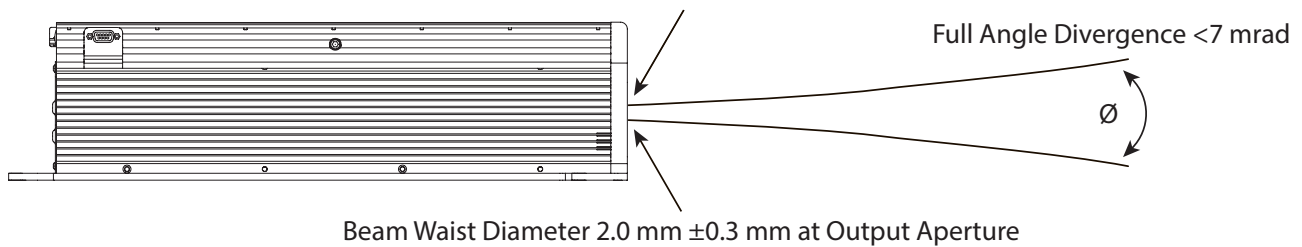

Figure 4-1 Beam characteristics. \*  $M^2 < 1.3$  for 9.3  $\mu\text{m}$  and 10.2  $\mu\text{m}$  models.

## Controlling Laser Power

### Internal RF power supply

Ti-Series lasers are driven by a compact radio frequency (RF) power supply mounted internally in the laser chassis to make them more compact and energy efficient. The 48 VDC input voltage is converted into a high-power RF signal using an RF power oscillator. The output from the RF oscillator (nominally at 83.5 MHz) drives the laser directly by exciting carbon dioxide ( $\text{CO}_2$ ) gas in the tube to produce lasing.

### Control circuitry

Switches and sensors built into the ti-Series control board monitor the laser for conditions like under/over voltage, over temperature, and No-Strike faults that pose a risk of damage to the laser. Additionally, laser operation is controlled by the following: a manual Shutter Switch and manual Keyswitch (on Keyswitch-equipped lasers); the Shutter Open Request input; the Remote Interlock input; and the Remote Reset/Start Request input.

# Technical Reference

## Technical Overview

### Optical Setup

After selecting a laser for a CO<sub>2</sub> laser processing system, the two most important elements to consider are: (1) beam delivery optics to transmit the beam to the work area; and (2) focusing optics to focus the beam onto the part or material to be processed. Each element is crucial in the development of a reliable laser-based material processing system and each element should be approached with the same careful attention to detail.

### Beam Delivery Optics

Divergence, or expansion, of the laser beam is important in materials processing since a larger beam entering the focusing optic produces a smaller focused spot. Because the ti-Series laser beam diverges by 7 mm over each meter of distance traveled, the laser should be mounted a distance of 1.0–1.5 m (40–60 in) away from the work area and no closer than 0.75 m (30 in) for optimum performance. Right angle turning mirrors (beam benders) are often used in conjunction with the laser mounting position to obtain this distance.

Expander/collimators are optical devices that reduce laser divergence while at the same time increasing beam diameter by a selectable magnification factor. Adding an expander/collimator substantially reduces beam divergence and any variance in beam diameter caused by the changing optical path length in an XY (“flying optics”) table application. In fixed-length delivery systems where the laser is positioned only one meter away from the focusing optic and a small spot size is required, an expander/collimator is again the best solution to provide the required beam expansion before reaching the focusing optic.

**Tip:** Optical components in the beam path must always be aligned to the actual beam path, not the laser faceplate. Because of slight variations in laser construction, the beam path may not always be centered in, or perpendicular to, the aperture in the faceplate.

### Focusing optics

When selecting a focusing optic, the primary consideration should be material thickness and any vertical tolerances that occur during final part positioning rather than making a selection based only on minimum spot size. The chosen focal length should create the smallest possible focused spot while providing the depth of field required for the material being processed.

Optics are fragile and must be handled carefully, preferably by the mounting ring only. Be careful to select optics that are thick enough to withstand the maximum assist gas pressure available for the process. This is especially important in metal cutting applications using high-pressure assist gases.

Cleanliness is another important issue affecting performance and becomes increasingly important as laser power increases. Dirty or scratched lenses will under perform, exhibit a vastly shortened lifetime, and may fail catastrophically.

# Technical Reference

## Technical Overview

When the application requires air (instead of nitrogen) as an assist gas, use only breathing quality air available in cylinders from a welding supply company. Compressed shop air contains minute particles of oil and other contaminants that will damage optical surfaces. If compressed shop air is the only choice available, it must be filtered and dried to ISO 8573-1:2010 Class 1, 2, 1 specifications shown in the table below.

## Assist Gas Specifications

Table 4-1 Assist gas purity specifications.

Assist Gas	Typical Purpose	Specification
Air	Cutting/Drilling	Breathing Grade particulate level $\geq 99.9996\%$ purity; filtered to ISO Class 1
Air	Cutting/Drilling	Compressed ISO 8573-1:2010 Instrument-grade air filtered and dried to Class 1, 2, 1 ( $\leq 10$ 1.0– 5.0 $\mu\text{m}$ particles/ $\text{m}^3$ ; $\leq -40$ °F dew point; $\leq 0.01$ $\text{mg}/\text{m}^3$ oil vapor)
Argon	Welding	High Purity Grade particulate level $\geq 99.998\%$ purity; filtered to ISO Class 1
Helium	Welding	High Purity Grade particulate level $\geq 99.997\%$ purity; filtered to ISO Class 1
Nitrogen	Cutting/Drilling	High Purity Grade particulate level $\geq 99.9500\%$ purity; filtered to ISO Class 1
Oxygen	Cutting/Drilling	Ultra Pure Grade $\geq 99.9998\%$ purity; filtered to ISO Class 1 particulate level

## Cooling Coolants

SYNRAD recommends that the laser's cooling fluid contain at least 90% distilled water by volume. In closed-loop systems, use a corrosion inhibitor/algaecide such as Optishield® Plus or equivalent as required. Avoid glycol-based additives because they reduce the coolant's heat capacity and high concentrations may affect power stability. For SYNRAD lasers, the minimum coolant setpoint is 18 °C (64 °F) so glycol is not necessary unless the chiller is subjected to freezing temperatures. If tap water is used, chloride levels should not exceed a concentration of 25 parts per million (PPM) and total hardness should be below 100 PPM. Install a filter on the chiller's return line and inspect frequently.



# Technical Reference

## Technical Overview

### Cooling & Setting coolant temperature

Choosing the correct coolant temperature is important to the proper operation and longevity of your laser. When coolant temperature is lower than the dew point (the temperature at which moisture condenses out of the surrounding air), condensation forms inside the laser housing leading to failure of laser electronics as well as damage to optical surfaces.

The greatest risk of condensation damage occurs when water-cooled lasers are run in a high heat/high humidity environment and the chiller's coolant temperature is colder than the dew point temperature of the surrounding air or when the system is shut down, but coolant continues to flow through the laser for extended periods of time.

The chiller's temperature setpoint must always be set above the dew point temperature. In cases where this is not possible within the specified coolant temperature range of 18 °C to 22 °C (64 °F to 72 °F), then the following steps **MUST** be taken to reduce the risk of condensation damage.

- Stop coolant flow when the laser is shut down.
- Increase coolant flow by an additional 3.8 LPM (1.0 GPM). Do not exceed a coolant pressure of 414 kPa (60 PSI).

To use the following dew point table, look down the Air Temp column and locate an air temperature in Fahrenheit or Celsius (°C values are shown in parentheses) that corresponds to the air temperature in the area where your laser is operating. Follow this row across until you reach a column matching the relative humidity in your location. The value at the intersection of the Air Temp and Relative Humidity columns is the Dew Point temperature in °F (or °C). The chiller's temperature setpoint must be set above the dew point temperature.

For example, if the air temperature is 85 °F (29 °C) and the relative humidity is 60%, then the dew point temperature is 70 °F (21 °C). Adjust the chiller's temperature setpoint to 72 °F (22 °C) to prevent condensation from forming inside the laser.

Refer to the dew point temperature table within the prior chapter for a range of air temperature and relative humidity values. Remember that the laser's coolant temperature must be set above the dew point temperatures shown in the chart, but should not exceed the environmental specifications located in the Ti-Series General Specifications within the Technical References chapter of this manual.

# Technical Reference

## Technical Overview

Table 4.2 Dew point temperatures.

Relative Humidity (%) Dew Point Table

Air Temp °F/°C	20%	25%	30%	35%	40%	45%	50%	55%	60%	65%	70%	75%	80%	85%	90%	95%
60 °F	-	-	-	32	36	39	41	44	46	48	50	52	54	55	57	59
16 °C	-	-	-	0	2	4	5	7	8	9	10	11	12	13	14	15
65 °F	-	-	33	37	40	43	46	48	51	53	55	57	59	60	62	64
18 °C	-	-	1	3	4	6	8	9	11	12	13	14	15	16	17	18
70 °F	-	33	37	41	45	48	51	53	56	58	60	62	64	65	67	69
21 °C	-	1	3	5	7	9	11	12	13	14	16	17	18	18	19	21
75 °F	-	37	42	46	49	52	55	58	60	62	65	67	68	70	72	73
24 °C	-	3	6	8	9	11	13	14	16	17	18	19	20	21	22	23
80 °F	35	41	46	50	54	57	60	62	65	67	69	71	73	75	77	78
27 °C	2	5	8	10	12	14	16	17	18	19	21	22	23	24	25	26
85 °F	40	45	50	54	58	61	64	67	70	72	74	76	78	80	82	83
29 °C	4	7	10	12	14	16	18	19	21	22	23	24	26	27	28	28
90 °F	44	50	54	59	62	66	69	72	74	77	79	81	83	85	87	88
32 °C	7	10	12	15	17	19	21	22	23	25	26	27	28	29	31	31
95 °F	48	54	59	63	67	70	73	76	79	81	84	86	88	90	92	93
35 °C	9	12	15	17	19	21	23	24	26	27	29	30	31	32	33	34
100 °F	52	58	63	68	71	75	78	81	84	86	88	91	93	95	97	98
38 °C	11	14	17	20	22	24	26	27	29	30	31	33	34	35	36	37

# Technical Reference

## Technical Overview

- Air-condition the room or the enclosure containing the laser.
- Install a dehumidifier to reduce the humidity of the enclosure containing the laser.

The prior table provides dew point temperatures for a range of air temperature and relative humidity values. Remember that the laser's coolant temperature must be set above the dew point temperatures shown in the chart; refer to the cooling specifications at the end of this chapter.

## Control signals

- Control signals
- Operating modes

Much of the information provided in this section describes the use of a SYNRAD UC-2000 Universal Laser Controller to provide PWM Command signals to the ti-Series laser. If using an alternate method of laser control, thoroughly review this section, Controlling laser power, as well as the following section, User I/O connections, for an understanding of the signal requirements necessary for control. For more information about the UC-2000, please consult the UC-2000 Laser Controller Operator's Manual.

### Tickle pulse

Tickle pulses pre-ionize the laser gas to just below the lasing threshold so that a further increase in pulse width adds enough energy to the plasma to cause laser emission. Tickle pulses cause the laser to respond predictably and almost instantaneously to PWM Command signals, even when there is considerable delay (laser off time) between applied Command signals. All ti-Series lasers incorporate a built-in tickle generator, freeing customers from the need to supply external tickle pulses between lasing commands.

Internal circuitry monitors the incoming PWM signal and determines the amount of time the laser was on (lasing) during the last 200 microsecond ( $\mu\text{s}$ ) interval. If the laser's on time was greater than the preset tickle value, then no tickle pulse is generated, because the PWM signal was sufficient to maintain a plasma state. If no PWM signal was applied during the 200- $\mu\text{s}$  measurement period (or was shorter than the preset tickle value), internal circuitry generates a tickle pulse such that the laser always receives a pre-set amount of RF drive averaged over any 200- $\mu\text{s}$  interval.

### Pulse Width Modulation (PWM)

Pulse Width Modulation, or PWM, controls laser power by varying the duty cycle of your laser's RF amplifiers, which in turn control the time-averaged RF power applied to the laser. Typically, laser output follows the PWM input with a rise and fall time constant of  $\sim 75 \mu\text{s}$ ; however, the laser cannot precisely follow PWM input signals if the "On" pulse is less than  $75 \mu\text{s}$  in duration. At a constant 50% duty cycle, ti-Series lasers typically reach 90–100% of full optical output when operated at a frequency of 5 kHz. The percentage of optical output increases as duty cycle increases (at a constant PWM frequency) or as PWM frequency decreases (at a constant

# Technical Reference

## Controlling Laser Power

duty cycle). The figure on the following page shows representative ti-Series optical output waveforms at two different duty cycles with the same PWM frequency.

Ti-Series lasers are designed to operate at Command signal base frequencies up to 160 kHz; however, the choice of PWM frequency depends on the user's specific application. In the majority of laser applications, the UC-2000's default Command signal frequency of 5 kHz has proven to work well. When considering Command frequencies at 5 kHz or below, please review Marking/engraving operation later in this section. For high-speed motion applications that cannot tolerate any ripple in the optical beam response but still need adjustable power levels, we recommend the use of higher PWM frequencies, up to 160 kHz maximum.

### Command signal

The modulated Command signal applied between Pin 9, PWM Input, and Pin 1, PWM Return, of the User I/O connector on the ti-Series laser has three basic parameters: signal amplitude, base frequency, and PWM duty cycle. By changing these parameters, you can command the beam to perform a variety of marking, cutting, welding, or drilling operations.

The first Command signal parameter, signal amplitude, is either logic low—corresponding to laser beam off, or logic high—corresponding to beam on. The laser off voltage, typically 0 V, can range from 0.0 V to +0.8 VDC while the laser on voltage, typically 5 V, can range from +3.5 V to +6.7 VDC.

Base frequency, the second parameter, is the repetition rate of the PWM input signal. The standard base frequency is 5 kHz, which has a period of 200  $\mu$ s. Maximum PWM frequency is 160 kHz.

The third Command signal parameter, PWM duty cycle, is the percentage of the period that the Command signal is high. If the Command signal's amplitude (at 5 kHz) is high for 100  $\mu$ s and low for 100  $\mu$ s, it has a 50% duty cycle; if the amplitude is high for 190  $\mu$ s and low for 10  $\mu$ s, it has a 95% duty cycle. The following figure illustrates PWM Command signal parameters while the following table lists PWM signal specifications.

**Warning**  
Serious  
personal  
injury



*Because of phase differences, external tickle pulses may combine with the internally-generated tickle signal causing the LASE LED to flicker during the transition from tickle to lasing. Laser output may occur if the LASE LED flickers.*

Your user I/O PWM input consists of a high-speed optoisolator LED with a forward voltage drop ( $V_f$ ) of 1.5 VDC. The PWM input frequency can range from DC (0 Hz) to 160 kHz. The following table provides minimum, maximum, and nominal PWM signal specifications.

# Technical Reference

## Controlling Laser Power

Table 4-2 PWM command signal specifications.

Laser State	Minimum	Nominal	Maximum
Laser Off	0.0 VDC	0.0 VDC	+0.8 VDC
Laser On	+3.5 VDC (3 mA)	+5.0 VDC (6 mA)	+6.7 VDC (10 mA), continuous
Frequency Range	0 Hz (DC)	5 kHz	160 kHz
Duty Cycle	0%	— —	100%

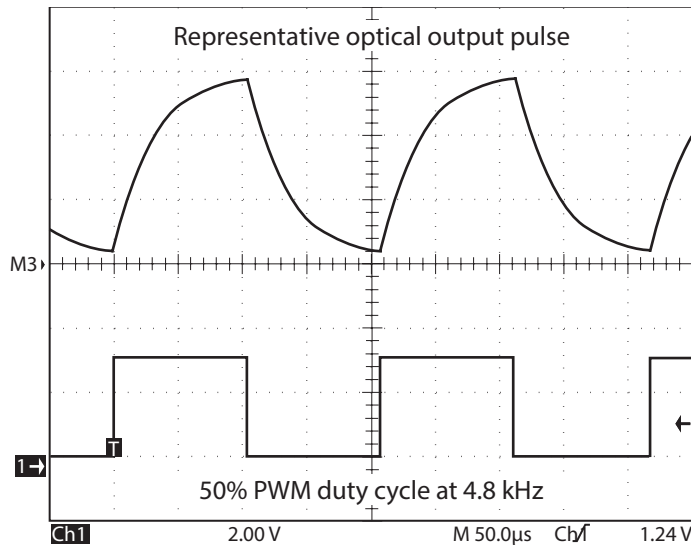

Figure 4-2 4.8kHz ti-Series waveform at 50% duty cycle.

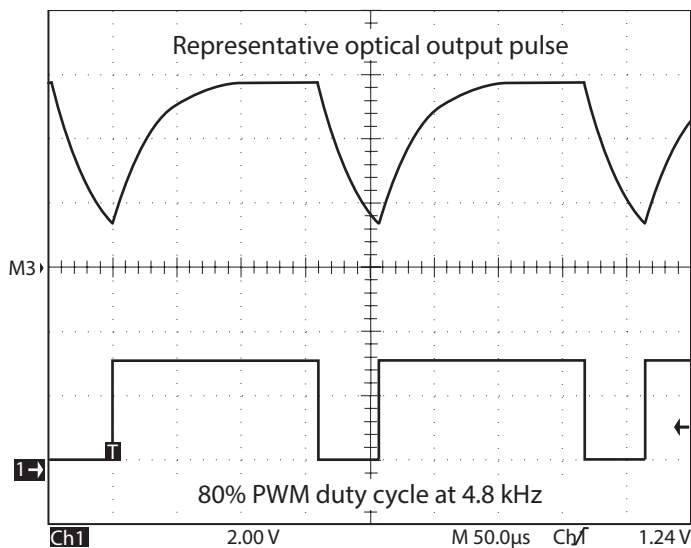

Figure 4-3 4.8kHz ti-Series waveform at 80% duty cycle.

# Technical Reference

## Controlling Laser Power

### Operating modes

#### External control

In addition to controlling the laser using a UC-2000 Controller, controlling externally without a UC-2000, is also possible. The two primary elements of laser control are gating, the ability to turn the laser on and off at the appropriate times, and power, the ability to control the laser's output energy. Both gating and power can be handled by a device such as a personal computer, Programmable Logic Controller (PLC), or function generator capable of sending PWM pulses at the proper time (gating) and with the proper duty cycle (power).

#### **Warning**

**Serious  
personal  
injury**



*Always use shielded cable when connecting your PWM Command signal source to the laser's CTRL connections.*

*In electrically-noisy environments, long lengths of unshielded wire act like an antenna and may generate enough voltage to trigger uncommanded lasing.*

#### Analog voltage or current control

Although ti-Series lasers cannot be controlled directly by analog voltage or current signals, this type of control is possible when using the UC-2000 Controller. The Controller is connected normally to the laser and analog voltage or current signals sent to the UC-2000's ANV/C connector then control both laser gating and power.

To generate the correct analog voltage from a computer or PLC, a Digital-to-Analog (D/A or DAC) card capable of generating 0 V (laser off) to 10 V (maximum laser power) must be installed. To generate the proper analog current, install a D/A card that can generate 4 mA (laser off) to 20 mA (maximum power). Software able to control your analog output card is required for either configuration.

#### Continuous wave (CW)

In some applications, such as high speed marking or cutting, the time constant of the laser and the PWM modulation causes a series of dots that may be visible on the marking surface instead of a "clean" line. Operating the laser in CW mode will prevent this behavior from occurring.

# Technical Reference

## Controlling Laser Power

To operate the laser in CW mode, apply a constant +5 VDC signal to Pin 9, PWM Input, and Pin 1, PWM Return, on the User I/O connector. This constant voltage source forces the internal switching electronics to remain on, providing continuous and uninterrupted laser output power. During CW operation, output power cannot be changed. To adjust output power, refer back to the Pulse Width Modulation (PWM) section for information regarding high frequency operation.

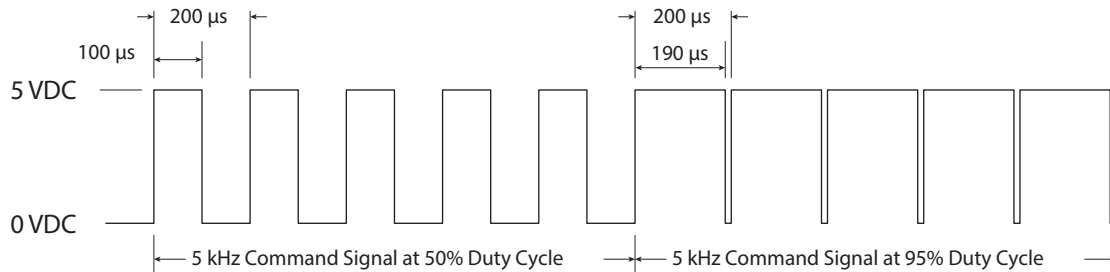

Figure 4-4 PWM signal waveform.

### Gated operation

In many marking and cutting applications, the laser is required to pulse, or gate, on and off in synchronization with an external control signal (typically from a computer or function generator operating in the range from DC to 1 kHz). To pulse or gate the laser, connect a signal providing +5.0 VDC pulses to the Gate connector on the rear panel of the UC-2000.

Users who intend to use a gating signal should set the UC-2000's gate input logic to internal Pull-Down (normally off) mode. This prevents the beam from being enabled unless a high level (+3.5 V to +5.0 VDC) signal is applied to the Gate input connector. In the pull-down (normally off) mode, an asserted logic low signal, short circuit to ground, or an open or disconnected Gate input locks the beam off.

Many CO<sub>2</sub> lasers operating in applications requiring short gating pulses at repetition rates below 500 Hz will exhibit some leading edge overshoot regardless of the PWM frequency. This occurs because a cooler lasing medium (the CO<sub>2</sub> gas) is more efficient than a hotter one. The overshoot effect is more pronounced at lower gating frequencies since the gas has a longer time to cool down between Command signal pulses.

SYNRAD ti-Series lasers produce an optical output pulse that is almost exactly square (see the figure below), meaning that there is no leading edge overshoot and virtually no power variation across the actual pulse. The square output pulse of the ti-Series laser coupled with its shorter rise times (~75 μs) means that material processing is more efficient since a greater amount of laser energy is absorbed, which is especially desirable when working with high threshold materials.

### Marking/engraving operation

When the delay between the end of one PWM Command signal pulse and the beginning of the next PWM pulse exceeds 200 microseconds (less than or equal to 5 kHz), your laser's on-board tickle generator sends a tickle pulse to maintain plasma ionization in the tube. Because the on-board tickle generator can not anticipate when the next PWM Command pulse will

# Technical Reference

## Controlling Laser Power

arrive, the tickle pulse (which typically lasts for 2–6  $\mu\text{s}$  depending on the laser) can effectively merge with a PWM signal that follows closely afterwards. When the PWM pulse that follows is short, causing the tickle pulse to become a significant fraction of the PWM pulse duration, then the tickle pulse effectively substantially increases the length of the PWM pulse it has merged with. For subtle marking applications on sensitive, low threshold materials this lengthened PWM pulse may affect mark quality.

While this situation can occur when using PWM Command signal frequencies of 5 kHz and less, it is important to note that it isn't the Command signal frequency itself that is the determining factor but rather this behavior happens only when the off time between PWM pulses exceeds 200 microseconds.

**Note:** SYNRAD lasers are designed for maximum performance using a 95% duty cycle. Increasing the maximum PWM percentage beyond 95% greatly increases the laser's heat load with little or no corresponding increase in laser output power.

### Warning Serious personal



*The UC-2000's default gate logic is factory set to internal Pull-Up (normally on) mode so that an open (disconnected) Gate input causes the laser to turn on. This functionality allows the user to easily test and verify laser operation prior to integration. In an integrated system, you should configure the UC-2000's gate input*

*This prevents the beam from being enabled unless a high level (+3.5 V to +5.0 VDC) signal is applied to the Gate input connector. In the Pull-Down (normally off) mode an asserted logic low signal, short circuit to ground, or an open or disconnected Gate inputs locks the beam off.*

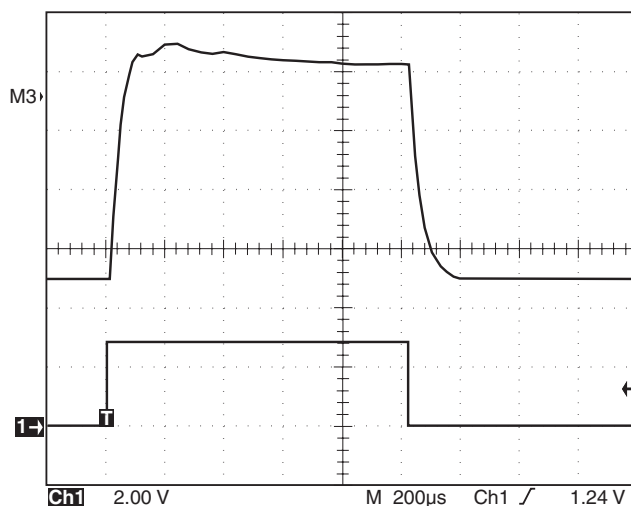

Optical output pulse (10% duty cycle at 100 Hz)

Figure 4-4 Representative ti-Series optical output pulse.



# Technical Reference

## User I/O Connections

### User I/O connection summary

- User I/O connection summary
- Input/output signals
- Sample I/O circuits

The table below provides a quick reference summary for ti-Series User I/O connections.

Table 4-3 User I/O pin descriptions.

#### Pin Function & Description

#### Input/output signals

<b>Pin 1</b>	<b>PWM Return</b>
	Use this input pin as the return side of the PWM Command signal.
<b>Pin 2</b>	<b>Remote Reset/Start Request Input</b>
	Apply a positive or negative voltage ( $\pm 5$ –24 VDC) with respect to Pin 11, Input Common, to reset or remote keyswitch the laser. The laser remains disabled while voltage is applied. Removing voltage from the Remote Reset/Start Request pin causes the laser's RDY indicator to illuminate. On Keyswitch lasers, a five-second delay occurs before lasing is enabled.

**Note:** When connecting field wiring to the Remote Reset/Start Request input, use twisted pair and/or shielded cabling. Refer to SYNRAD Technical Bulletin #21 for details.

<b>Pin 3</b>	<b>Remote Interlock Input</b>
	Apply a positive or negative voltage ( $\pm 5$ –24 VDC) with respect to Pin 11, Input Common, to enable lasing. If your system does not use an interlock, connect this pin to a $\pm 5$ –24 VDC source (refer to the following Auxillary DC power supply wiring figure that shows how the Remote Interlock input is factory-jumpered on the Quick Start Plug). On Keyswitch lasers, a five-second delay occurs after the interlock is enabled.
<b>Pin 4</b>	<b>+5 VDC Auxillary Power</b>
	This connection provides +5 VDC for driving external inputs or outputs. The +5 VDC Auxillary Power output can source up to 0.5 A and is protected by a 0.5 A self-resetting fuse. The return (ground) path must be through Pin 12, Auxillary DC Power Ground.
<b>Pin 5</b>	<b>+24 VDC Auxillary Power</b>
	This connection provides +24 VDC for driving external inputs or outputs. The +24 VDC Auxillary Power output can source up to 0.5 A and is protected by a 0.5 A self-resetting fuse. The return (ground) path must be through Pin 12, Auxillary DC Power Ground.

# Technical Reference

## User I/O Connections

Input/output signals are divided into three categories: auxiliary DC power, input signals, and output signals. Signals in each category are fully described in the section below. The following figure illustrates the pin arrangement of the User I/O (15 pin female D-type subminiature) connector on the laser's rear panel.

Table 4-3 User I/O pin descriptions (continued).

### Pin Function & Description

Pin	Function & Description
<b>Pin 6</b>	<b>Laser Active output</b>
	This bi-directional switched output is internally connected to Pin 13, Output Common, when the laser is actively lasing (LASE indicator illuminated red). This output is open, in a high-impedance state, when no beam is being emitted (LASE indicator Off).
<b>Pin 7</b>	<b>Fault Detected output</b>
	This bi-directional switched output is internally connected to Pin 13, Output Common, when an over temperature fault (TMP LED is red) or other improper operating condition (SHT indicator is flashing) exists. The output is open, in a high-impedance state, when laser operation is within limits (TMP LED green and SHT LED blue).
<b>Pin 8</b>	<b>Laser Ready</b>
	This bi-directional switched output is internally connected to Pin 13, Output Common, when the laser is enabled (RDY indicator illuminated yellow), indicating that lasing will occur when a PWM Command signal is applied to Pin9 and Pin 1. This output is open, in a high-impedance state, when the laser is disabled (RDY indicator Off).
<b>Pin 9</b>	<b>PWM Input</b>
	Connect your PWM Command signal (+5 VDC, 5 kHz nominal, 160 kHz max, pulse width modulated) to this input pin to control laser output power. Refer back to Controlling laser power for further information on laser control signals.
<b>Pin 10</b>	<b>Shutter Open Request input</b>
	Apply a positive or negative voltage ( $\pm 5$ –24 VDC) with respect to Pin 11, Input Common to enable lasing. If your system does not use a shutter, connect this pin to a $\pm 5$ –24 VDC source (Refer to the following Auxiliary DC power supply wiring figure that shows how the Shutter Open Request input is factory-jumpered on the Quick start Plug). On Keyswitch lasers, a five-second delay occurs after this input is enabled.
<b>Pin 11</b>	<b>Input Common</b>
	Use this input pin to connect return lines for Remote Interlock, Shutter Open Request, and Remote Reset/Start Request lines.

**Note:** See DB-9 connections later in this section for signal descriptions and pinouts of the SA model's side-mounted DB-9 connector.

# Technical Reference

## User I/O Connections

### **Caution** Possible Equipment Damage

Turn off DC power before installing or removing any plug or cable from the User I/O connector. Ensure that user connections are made to the appropriate pins and that the appropriate signal levels are applied. Failure to do so may damage the laser.

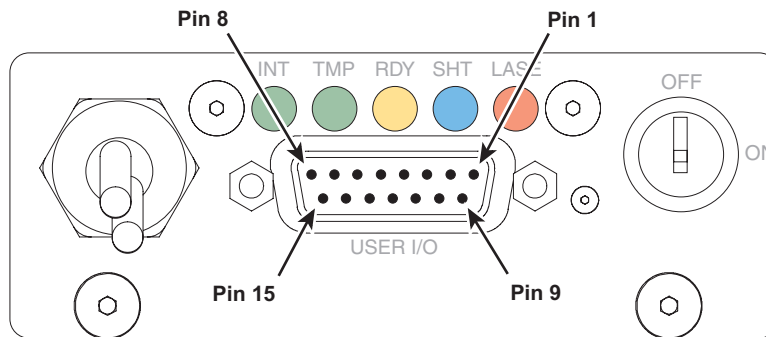

Figure 4-5 User I/O pinouts.

Table 4-3 User I/O pin descriptions (continued).

Pin	Function & Description
<b>Pin 12</b>	<b>Auxiliary DC Power Ground</b>
	This connection provides a ground (earth) connection for +5 and +24 VDC auxiliary power outputs. This pin is the only User I/O pin that is connected to chassis ground. Do not use this pin for grounding if DC power to external I/O circuits is supplied from an external customer-supplied DC power source.
<b>Pin 13</b>	<b>Output Common</b>
	Use this pin to complete the return path for output connections (Pin 6, 7, 8, 14, or 15). The Output Common line is protected by a 0.25 A self-resetting fuse.
<b>Pin 14</b>	<b>Shutter Open output</b>
	This bi-directional switched output is internally connected to Pin 13, Output Common, when the Shutter Switch is Open (Key switch-equipped lasers) and a Shutter Open Request signal is present (SHT indicator illuminated blue), indicating that lasing may be enabled if other operating conditions are met. This output is open, in a high impedance state, when the laser is disabled (SHT indicator Off).
<b>Pin 15</b>	<b>Interlock Open output</b>
	This bi-directional switched output is internally connected to Output Pin 13, Common, when remote interlock circuitry is open (INT indicator illuminated red), indicating that lasing is disabled. The output is open, in a high-impedance state, when lasing is enabled (INT indicator green).

# Technical Reference

## User I/O Connections

### Auxiliary DC power

User I/O connector provides auxiliary DC power for driving external inputs or outputs connected to the User I/O port. Pin 4, +5 VDC Auxiliary Power, and Pin 5, +24 VDC Auxiliary Power, are protected by self-resetting fuses rated at 0.5 A. Pin 12, Auxiliary DC Power Ground, is connected to chassis ground while all other User I/O pins are floating with respect to chassis ground. The figure below illustrates internal DC supply wiring.

#### DC POWER INPUT

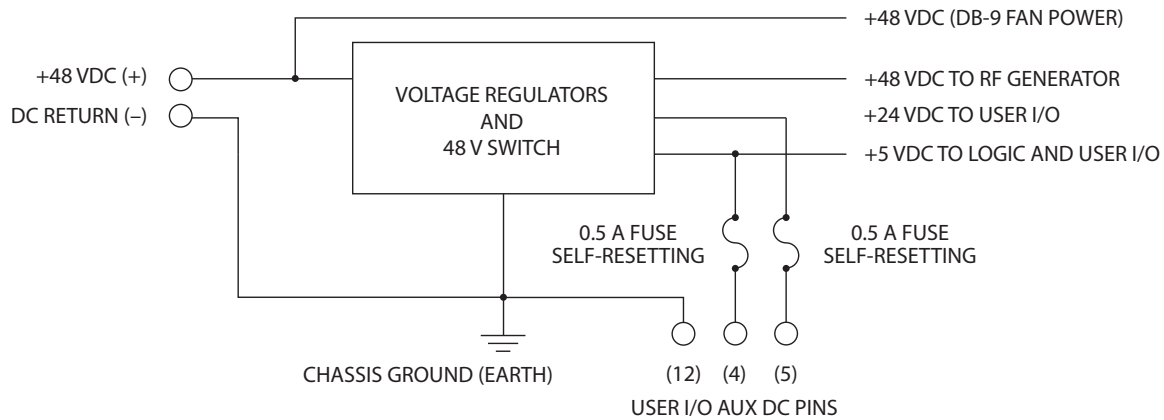

Figure 4-6 Auxillary DC power supply wiring.

Table 4-4 Auxillary Power for external I/O.

#### Pin Function & Description

Pin	Function & Description
<b>Pin 4</b>	<b>+ 5 VDC Auxiliary Power</b>
	This connection provides +5 VDC for driving external inputs or outputs. The +5 VDC Auxiliary Power output can source up to 0.5 A and is protected by a 0.5 A self-resetting fuse. The return (ground) path must be through Pin 12, Auxiliary DC Power Ground.
<b>Pin 5</b>	<b>+ 24 VDC Auxiliary Power</b>
	This connection provides +24 VDC for driving external inputs or outputs. The +24 VDC Auxiliary Power output can source up to 0.5 A and is protected by a 0.5 A self-resetting fuse. The return (ground) path must be through Pin 12, Auxiliary DC Power Ground.
<b>Pin 12</b>	<b>Auxiliary DC Power Ground</b>
	This connection provides a ground (earth) connection for +5 and +24 VDC auxiliary power outputs. This pin is the only User I/O pin that is connected to the laser's chassis ground. Do not use this pin for grounding if I/O circuits are powered from an external customer-supplied DC power source.

# Technical Reference

## User I/O Connections

### Input signals

Four inputs allow control of ti-Series lasers. Remote Reset/Start Request, Remote Interlock, and Shutter Open Request inputs are optoisolated and bi-directional to allow positive or negative polarity inputs. These three signals share a common return, Input Common, which is separate from chassis ground to completely isolate control signals for optimal EMI performance. The fourth input, PWM Input, is optoisolated with a separate return line, PWM Return, to isolate PWM signals from the other three inputs.

Table 4-5 Input signal table.

Pin	Function & Description
-----	------------------------

<b>Pin 1</b>	<b>PWM Return</b>
	Connect the return side of your PWM Command signal to this pin. Refer to following input specifications table for input circuit specifications.
<b>Pin 2</b>	<b>Remote Reset/Start Request input</b>
	<p>Apply a positive or negative voltage (<math>\pm 5</math>–24 VDC) with respect to Pin 11, Input Common, to disable the laser. The laser remains disabled while voltage is applied to this pin. Removing voltage from the Remote Reset/Start Request pin causes the laser's RDY indicator to illuminate. On Keyswitch-equipped lasers, a five-second delay occurs before lasing is enabled. Because all DC power is removed from the laser's RF driver when this input is active, no lasing can occur until voltage is removed from Pin 2. Refer to following input specifications table for input circuit specifications.</p> <p>For Keyswitch-equipped lasers in automated systems, the Remote Reset/Start Request input can operate as a remote keyswitch. To use this "remote keyswitch" functionality, first place the Keyswitch in the ON position. Then after each DC power-up cycle (or to reset a fault condition), apply a momentary voltage pulse in the range of <math>\pm 5</math>–24 VDC to Pin 2. This reset action initiates a five-second delay after which lasing is enabled.</p>

**Note:** When connecting field wiring to the Remote Reset/Start Request input, use twisted pair and/or shielded cabling. Refer to SYNRAD Technical Bulletin #21 for details.

Pin	Function & Description
-----	------------------------

<b>Pin 3</b>	<b>Remote Interlock input</b>
	<p>Apply a positive or negative voltage (<math>\pm 5</math>–24 VDC) with respect to Pin 11, Input Common, to enable lasing. If your system does not use a remote interlock, this pin must be connected to a voltage source in the range of <math>\pm 5</math>–24 VDC. Refer to the following Quick Start Plug wiring figure for a diagram showing how the Remote Interlock input is factory-jumpered on the Quick Start Plug. Because all DC power is removed from the laser's RF driver when this input is inactive, no lasing can occur until voltage is applied to Pin 3. Refer to following input specifications table for input circuit specifications.</p> <p>After voltage is removed and then re-applied to the Remote Interlock input on Keyswitch-equipped lasers, the Keyswitch or the Remote Reset/Start Request input must be toggled to restart the laser. This action initiates a five-second delay during which lasing is inhibited.</p>

# Technical Reference

## User I/O Connections

Table 4-5 Input signal table (continued).

Pin	Function & Description
<b>Pin 3</b>	<b>Remote Interlock input</b>
	<p>Apply a positive or negative voltage (<math>\pm 5</math>–24 VDC) with respect to Pin 11, Input Common, to enable lasing. If your system does not use a remote interlock, this pin must be connected to a voltage source in the range of <math>\pm 5</math>–24 VDC. Refer to the following Quick Start Plug wiring figure for a diagram showing how the Remote Interlock input is factory-jumpered on the Quick Start Plug. Because all DC power is removed from the laser's RF driver when this input is inactive, no lasing can occur until voltage is applied to Pin 3. Refer to following input specifications table for input circuit specifications.</p> <p>After voltage is removed and then re-applied to the Remote Interlock input on Key-switch-equipped lasers, the Keyswitch or the Remote Reset/Start Request input must be toggled to restart the laser. This action initiates a five-second delay during which lasing is inhibited.</p> <p>On OEM lasers, the Remote Interlock input is not latched. Re-applying a signal to Pin 3 enables laser output immediately, when the Shutter Open Request signal is present (SHT LED illuminated).</p>
<b>Pin 9</b>	<b>PWM Input</b>
	<p>Connect your PWM Command signal (+5 VDC, 5 kHz nominal, 160 kHz max) to Pin 9. This pulse width modulated Command signal controls laser output so that a duty cycle of 50% corresponds to a laser output of approximately one-half rated output power and a duty cycle of 95% corresponds to approximately full output power. Refer to Controlling laser power in this chapter for further information on laser control signals. Connect the PWM signal source return to Pin 1, PWM Return. Refer to following input specifications table for input circuit specifications.</p>
<b>Pin 10</b>	<b>Shutter Open Request input</b>
	<p>Apply a positive or negative voltage (<math>\pm 5</math>–24 VDC) with respect to Pin 11, Input Common, to enable lasing. If your system does not supply a Shutter Open Request signal, this pin must be connected to a voltage source in the range of <math>\pm 5</math>–24 VDC. Refer to Figure 3-7 for a diagram showing how the Shutter Open Request input is factory-jumpered on the Quick Start Plug. On Keyswitch-equipped lasers, a five-second delay occurs after the input is enabled. Because all DC power is removed from the laser's RF driver when this input is inactive, no lasing can occur until voltage is applied to Pin 10. Refer to following input specifications table for input circuit specifications.</p> <p>To enable Keyswitch-equipped lasers, you must apply a voltage (in the range of <math>\pm 5</math>–24 VDC) to the Shutter Open Request input and move the manual Shutter Switch to the Open position. Lasing is inhibited when voltage is removed from Pin 10 or the manual Shutter Switch is Closed.</p>
<b>Pin 11</b>	<b>Input Common</b>
	<p>Use this pin to connect return lines for Remote Interlock, Shutter Open Request, and Remote Reset/Start Request lines. Refer to following input specifications table for input circuit specifications.</p>

# Technical Reference

## User I/O Connections

The following figure illustrates how Remote Interlock and Shutter Open Request inputs are factory-jumpered on the Quick Start Plug to enable lasing for initial testing and troubleshooting purposes.

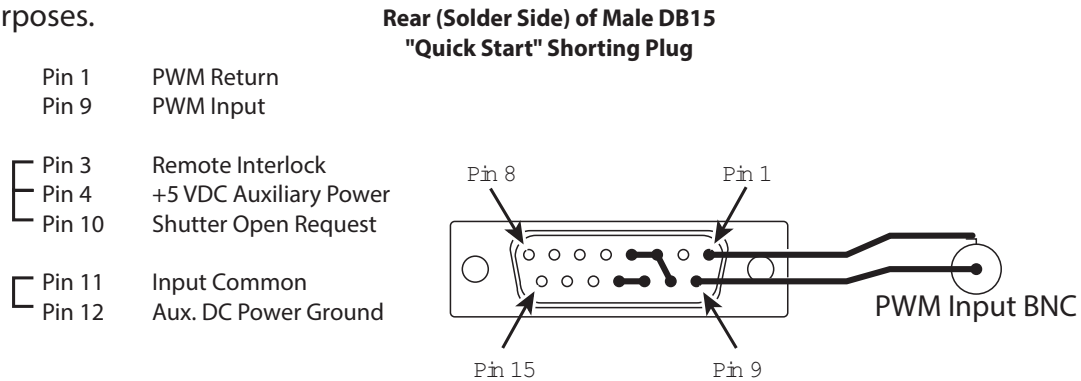

Figure 4-7 Auxillary DC power supply wiring.

**Warning**  
Serious  
personal  
injury



*The use of the Quick Start Plug bypasses the laser's safety interlock function, potentially exposing personnel in the area to invisible infrared laser radiation.*

*The Quick Start Plug is intended only for initial testing and troubleshooting by qualified personnel. In normal operation, the laser's Remote Interlock input should be connected to the machine's safety interlock circuitry.*

The figure below illustrates the input circuit's equivalent internal schematic while the table that follows provides ti-Series input circuit specifications.

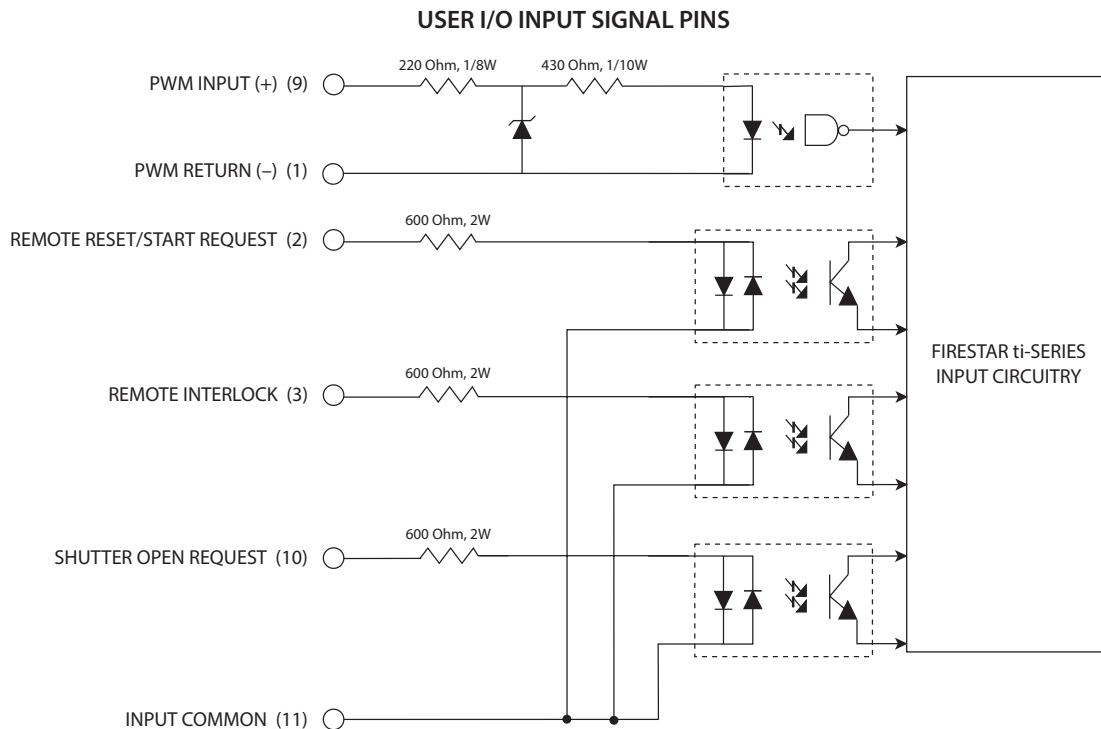

Figure 4-8 Input circuit specifications.

# Technical Reference

## User I/O Connections

Table 4-6 Input circuit specifications.

Input Signal Name	Input Device Type and Specifications
PWM Input	High-speed optoisolator LED, forward voltage drop ( $V_f$ ) 1.5 VDC Off state $V_{max}$ +0.8 VDC On state $V_{min}$ +3.5 VDC @ 3 mA On state (continuous) $V_{max}$ +6.7 VDC @ 10 mA Frequency, max. 160 kHz
Remote Reset/Start Request	Bi-directional optoisolator LED, forward voltage drop ( $V_f$ ) 1.15 VDC
Remote Interlock	Off state $V_{max}$ < 1.0 VDC
Shutter Open Request	On state $V_{min}$ $\pm$ 5.0 VDC @ 7 mA On state (continuous) $V_{max}$ $\pm$ 24.0 VDC @ 40 mA

**Note:** ! The Remote Reset/Start Request input must not be sent until +5 VDC power supply has stabilized (approximately 200 ms after DC power-up).

## Output signals

Ti-series five (5) user outputs correspond to the status functions described below. Outputs are optoisolated, bi-directional analog switches that allow for high-side or low-side switching. The shared connection, Output Common, is separate from the laser's chassis ground to allow high-side or low-side switching and to isolate control signals for optimum EMI performance.

Your laser's optically-isolated outputs are useful for sending laser status to a Programmable Logic Controller (PLC) or computerized control system. Each of the five outputs can source 50 mA at  $\pm$ 24 VDC maximum for a total load of 250 mA. For controlling larger loads, use these outputs to drive control relays.

**Note:** ! Laser Ready and Shutter Open outputs indicate separate functions. The RF driver is disabled until both Laser Ready and Shutter Open outputs are closed (both RDY and SHT LEDs On).

Table 4-7 Five user outputs & status functions.

Pin	Function & Description
Pin 6	<b>Laser Active output</b>
	This bi-directional switched output is internally connected to Pin 13, Output Common, when the laser is actively lasing (LASE indicator red). This output is open, in a high-impedance state, when no beam is being emitted (LASE indicator Off). Refer to the following table for output circuit specifications.



# Technical Reference

## User I/O Connections

Table 4-7 Five user outputs & status functions (continued).

Pin	Function & Description
<b>Pin 7</b>	<b>Fault Detected output</b>
	This bi-directional switched output is internally connected to Pin 13, Output Common, when an over temperature fault (TMP LED is red) or other improper operating condition (blue SHT indicator is flashing) exists. The output is open, in a high-impedance state, when laser operation is within limits (TMP LED green and SHT LED blue). Refer to the following table for output circuit specifications.
<b>Pin 8</b>	<b>Laser Ready output</b>
	This bi-directional switched output is internally connected to Pin 13, Output Common, when the laser is enabled (RDY indicator yellow), indicating that lasing will occur when a PWM Command signal is applied to Pin 9 and Pin 1. This output is open, in a high-impedance state, when the laser is disabled (RDY indicator Off). Refer to the following table for output circuit specifications.
<b>Pin 13</b>	<b>Output Common</b>
	Use this pin to complete the return (ground) path for any output connection (Pin 6, 7, 8, 14, or 15). The Output Common line is protected by a 0.3 A self-resetting fuse.
<b>Pin 14</b>	<b>Shutter Open output</b>
	This bi-directional switched output is internally connected to Pin 13, Output Common, when the Shutter Switch is Open (Keyswitch-equipped lasers) and a Shutter Open Request signal is present (SHT indicator blue), indicating that lasing may be enabled if other operating conditions are met. The output is open, in a high-impedance state, when the laser is disabled (SHT indicator Off). Refer to the following table for output circuit specifications.
<b>Pin 15</b>	<b>Interlock Open output</b>
	This bi-directional switched output is internally connected to Pin 13, Output Common, when remote interlock circuitry is open (INT indicator red), indicating that lasing is disabled. The output is open, in a high-impedance state, when lasing is enabled (INT indicator green). Refer to the following table for output circuit specifications.

# Technical Reference

## User I/O Connections

The following figure illustrates the output circuit's equivalent internal schematic and the following table provides ti-Series output circuit specifications.

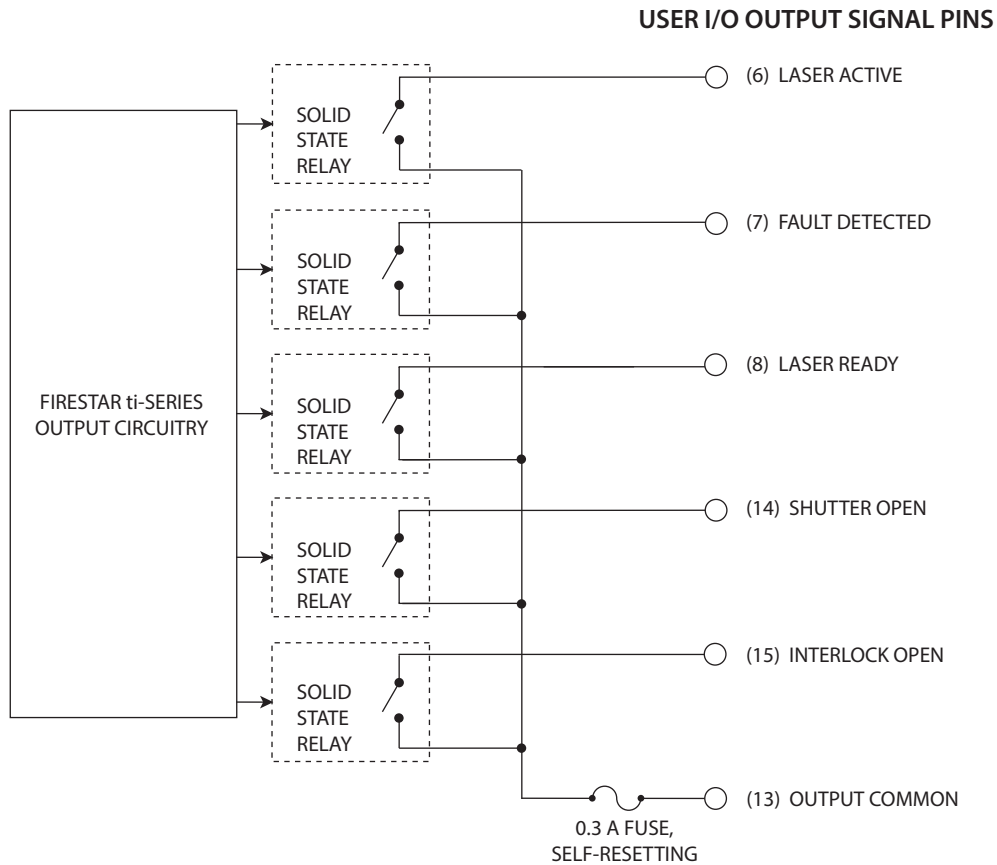

Figure 4-9 Output circuit specifications.

Table 4-8 Output circuit specifications.

Output Device	Specifications
Bi-directional MOSFET	2.5 Ohms Rdson 10 MOhms Off
	Voltage $\pm 24$ VDC, max.
	Current 50 mA, max.

# Technical Reference

## User I/O Connections

### Sample I/O circuits

#### Sample inputs

The figure below illustrates one method of supplying a Remote Interlock signal using a customer-supplied limit switch. Ti-series +24 VDC Auxiliary Power output powers the circuit. Note that Pin 4, +5 VDC Auxiliary Power, could have been used to power the circuit instead, depending on circuit voltage requirements.

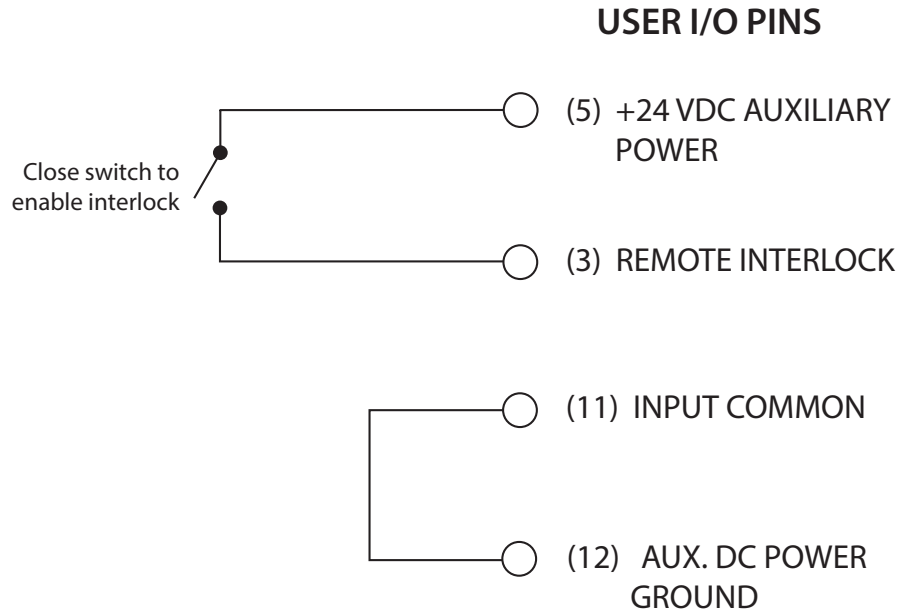

Figure 4-10 Customer-supplied interlock.

As shown in the figure below, another variation for supplying a Remote Interlock signal to the laser. In this case, the customer is using a switch and supplying a negative voltage to drive the laser's input circuit.

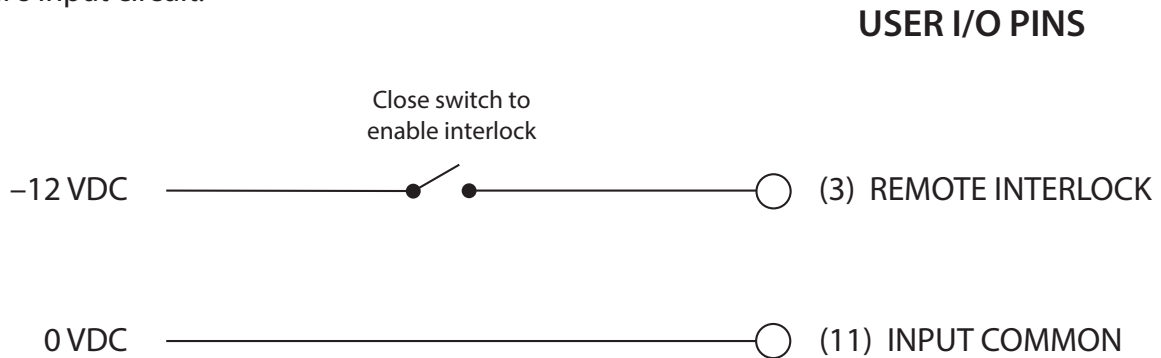

Figure 4-11 Customer-supplied interlock, negative voltage.

# Technical Reference

## User I/O Connections

A Programmable Logic Controller (PLC) can also drive inputs. The figure below shows a typical method for connecting to a PLC input module when only one input is used.

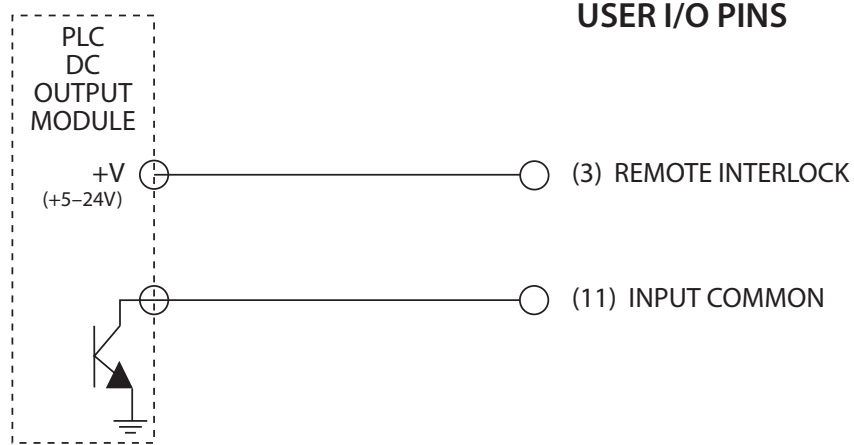

Figure 4-12 PLC driven interlock signal.

When multiple PLC inputs are required, connect inputs to the PLC as shown in the figure below. By supplying voltage (+VDC) to Pin 11, Input Common, and pulling individual inputs to ground, each input can be independently activated by the PLC's output module.

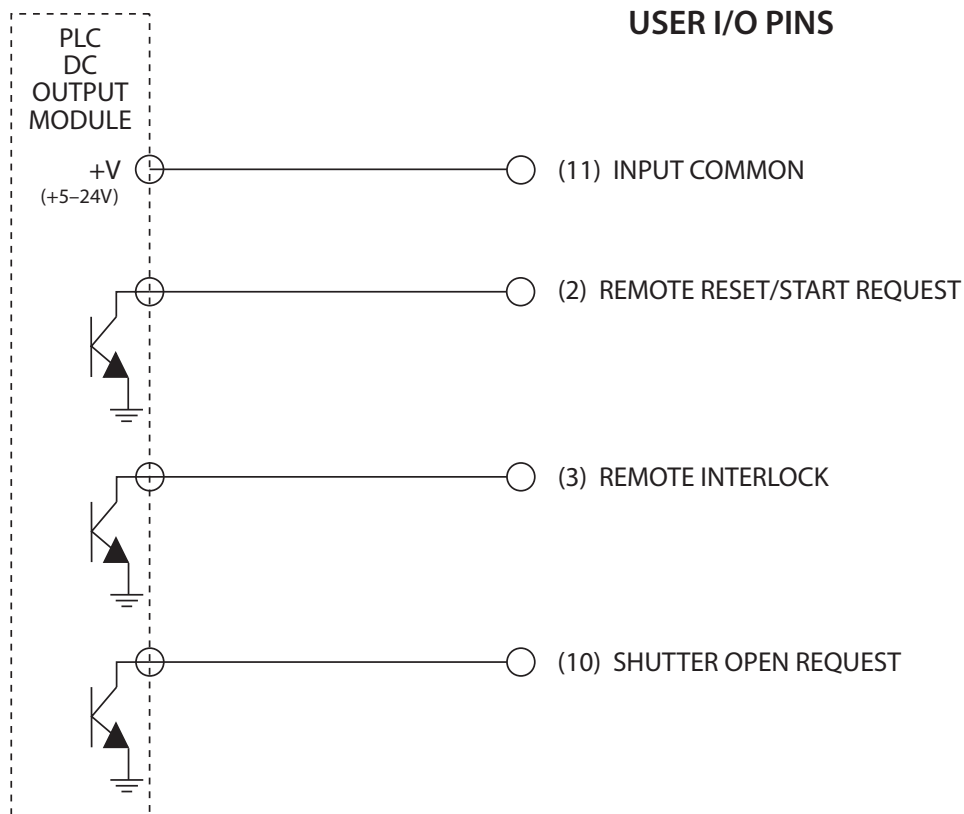

Figure 4-13 Multiple PLC driven inputs.

# Technical Reference

## User I/O Connections

### Sample outputs

Your laser's optoisolated, bi-directional switched outputs can drive small loads (50 mA max), PLC inputs, or relays that can control higher current loads. The following figure illustrates one method of controlling a remote warning lamp using power supplied by +24 VDC Auxiliary Power output. Remember to size current-limiting resistor, R1, so that the current draw does not exceed 50 mA.

#### USER I/O PINS

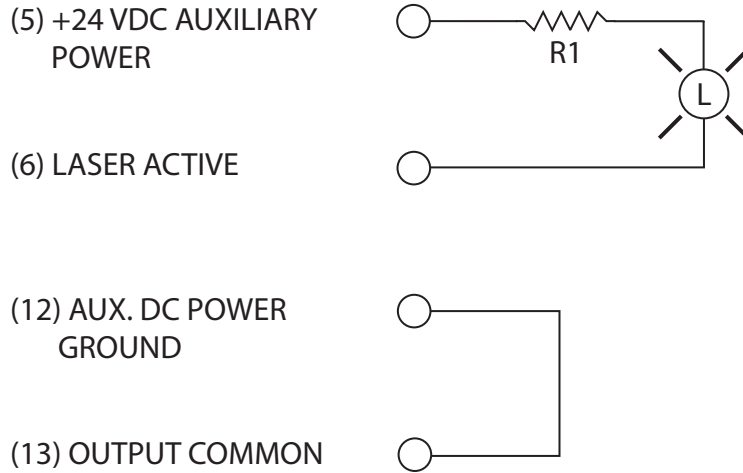

Figure 4-14 Output driving warning lamp.

The following figure illustrates a method for controlling a higher voltage, higher current load by using a 24 V control relay. Ensure that the relay coil's pull-in current does not exceed 50 mA. A diode or surge suppressor must be installed across the relay coil to prevent voltage spikes from damaging outputs.

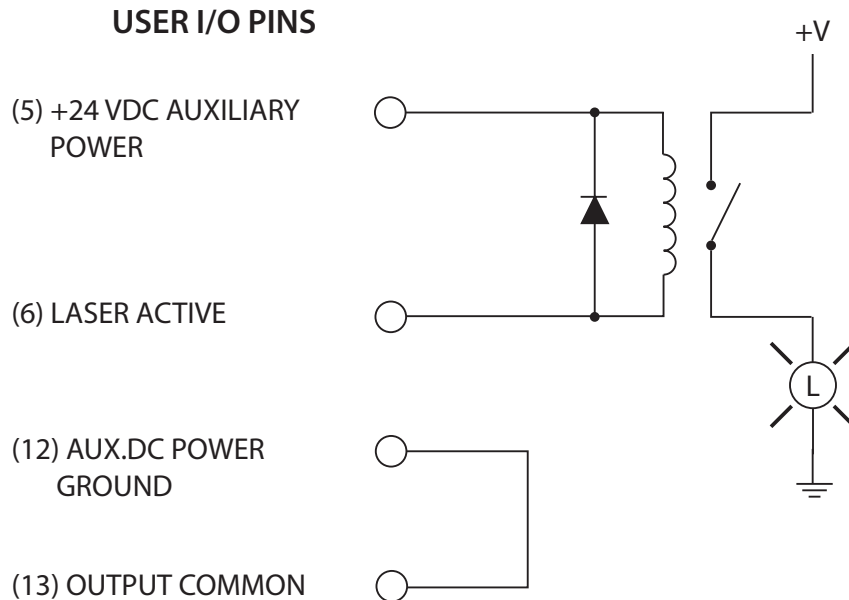

Figure 4-15 Output driving relay.

# Technical Reference

## User I/O Connections

The figure below illustrates how your laser's outputs can drive the DC Input Module of a Programmable Logic Controller (PLC). By supplying voltage (+VDC) to Pin 13, Output Common, each output is independently switched to activate individual PLC inputs.

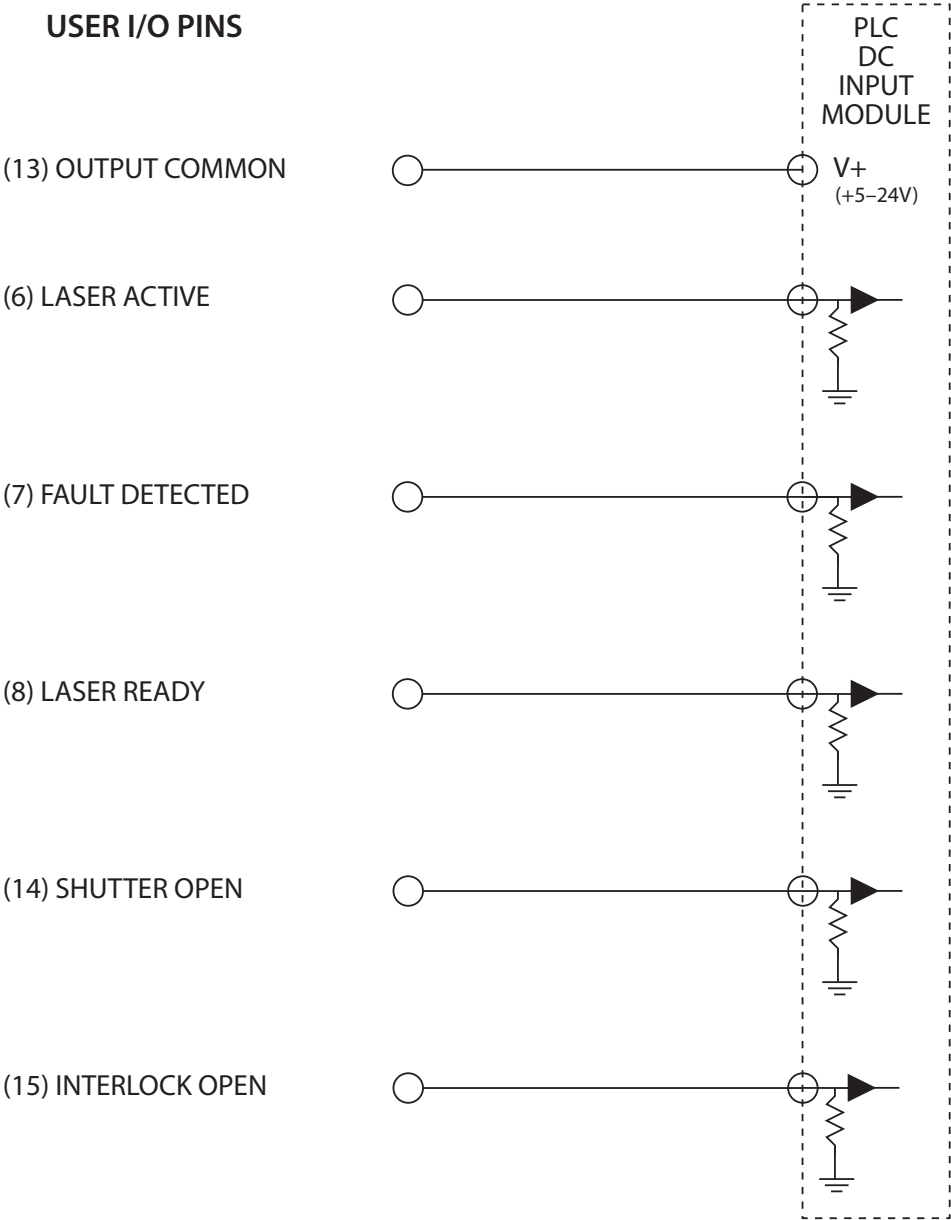

Figure 4-16 Output driving PLC input module.

# Technical Reference

## DB-9 I/O Connections (SA models only)

### DB-9 pin connections

- DB-9 pin descriptions
- 48 VDC fan speed control
- Isolated cooling fan connections

### DB-9 pin descriptions

The side-mounted DB-9 connector on SA model lasers provides a Shutter Switch input, auxiliary +5 V power, and +48 VDC for powering user-supplied 48 V cooling fans. The figure below illustrates DB-9 pinouts while the following table describes the function of each pin on the DB-9 connector.

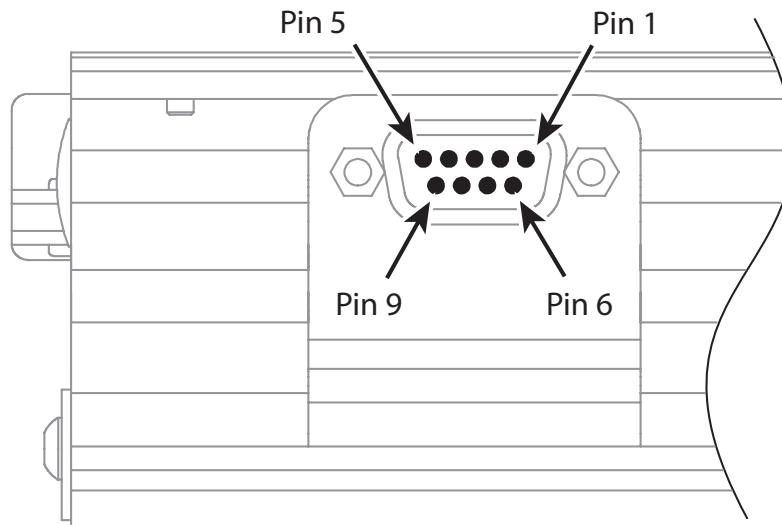

Figure 4-17 DB-9 connector pinouts.

**Important Note:** The pinout and functionality of the side-mounted DB-9 connector on ti-Series SA model lasers is **not** the same as the connector on t-Series or t70i SA model lasers.

Table 4-9 Side-mounted DB-9 pin descriptions.

Pin	Function & Description
-----	------------------------

<b>Pin 1</b>	<b>PWM Control Output (ti80 laser only)</b>
	This optoisolated output provides a 0–5 V pulse-width modulated (PWM) signal to drive the PWM input on variable-speed DC fans. This output is not current-limited or fused. The PWM output is driven by internal circuitry based on the laser’s output power and chassis temperature.

# Technical Reference

## DB-9 I/O Connections (SA models only)

Table 4-9 Side-mounted DB-9 pin descriptions (continued).

Pin	Function & Description
<b>Pin 2</b>	<b>Shutter Switch Input</b>
	On Keypswitch-equipped models, this input connects to the physical Shutter Switch. Leave this input open to enable lasing. Grounding this pin indicates that the shutter is Closed, which disables lasing. If connecting an external shutter switch to Pin 2, the circuit path must be grounded to Pin 6 or Pin 7, Signal Ground. With Keypswitch-equipped lasers, there is a five-second delay imposed from the time the shutter input is opened to the time that PWM Command signals are accepted.
<b>Pin 3</b>	<b>+ 5 VDC Auxiliary Power Output</b>
	This output provides +5 V for driving external inputs or outputs (like a diode pointer). The +5 VDC Auxiliary Power Output (Pin 3) is protected by a 0.5 A self-resetting fuse. The return (ground) path is through Pin 6 or Pin 7, Signal Ground.
<b>Pin 4</b>	<b>+ 48 VDC Fan Power Output</b>
	This output provides +48 V for powering a customer-supplied cooling fan. The + 48 VDC Fan Power Output (Pin 4) is sourced directly from the user's 48 V DC power supply and is protected by a 1.1 A self-resetting fuse. Pin 4 and Pin 8 can only source a combined current of 1.0 A total.
<b>Pin 5</b>	<b>Fan Power Return</b>
	This connection provides a return (ground) path for Pin 4 and Pin 8 (+ 48 VDC Fan Power Output) when using internal PWM fan control. Pin 5 and Pin 9 (Fan Power Return) can only sink a combined current of 1.0 A total. Internal circuitry allows the laser to control fan speed based on the laser's output power and chassis temperature. See 48 VDC fan speed control for detailed information.
<b>Pin 6</b>	<b>Signal Ground</b>
	Pin 6 and Pin 7 provide a return (ground) path for Pin 2 (Shutter Switch Input), Pin 3 (+5 VDC Auxiliary Power Output), or Pin 4/Pin 8 (+ 48 VDC Fan Power Output) when fan speed control is not required. Pin 6 and Pin 7, Signal Ground, are the only DB-9 pins connected to chassis ground. Do not use these pins if DC power is provided by an external customer-supplied DC power source.
<b>Pin 7</b>	<b>Signal Ground</b>
	Pin 6 and Pin 7 provide a return (ground) path for Pin 2 (Shutter Switch Input), Pin 3 (+5 VDC Auxiliary Power Output), or Pin 4/Pin 8 (+ 48 VDC Fan Power Output) when fan speed control is not required. Pin 6 and Pin 7, Signal Ground, are the only DB-9 pins connected to chassis ground. Do not use these pins if DC power is provided by an external customer-supplied DC power source.
<b>Pin 8</b>	<b>+ 48 VDC Fan Power Output</b>
	This output provides +48 V for powering a customer-supplied cooling fan. The + 48 VDC Fan Power Output (Pin 8) is sourced directly from the user's 48 V DC power supply and is protected by a 1.1 A self-resetting fuse. Pin 4 and Pin 8 can only source a combined current of 1.0 A total.



# Technical Reference

## DB-9 I/O Connections (SA models only)

Table 4-9 Side-mounted DB-9 pin descriptions (continued).

Pin	Function & Description
<b>Pin 9</b>	<b>Fan Power Return</b>
	This connection provides a return (ground) path for Pin 4 and Pin 8 (+ 48 VDC Fan Power Output) when using internal PWM fan control. Pin 5 and Pin 9 (Fan Power Return) can only sink a combined current of 1.0 A total. Internal circuitry allows the laser to control fan speed based on the laser's output power and chassis temperature. See 48 VDC fan speed control for detailed information.

## 48 VDC fan speed control

When operating air-cooled (SA model) ti-Series lasers with customer-supplied cooling fans, you can choose to run fans continuously at full-speed (no fan speed control) or at a variable speed using internal or external fan speed control. Each option is described below.

### No fan speed control

To operate 48 VDC cooling fans continuously at full-speed, connect the positive (+) fan leads to Pin 4 and Pin 8, + 48 VDC Fan Power Output, and connect the negative (-) fan leads to Pin 6 and Pin 7, Signal Ground as shown in the below figure.

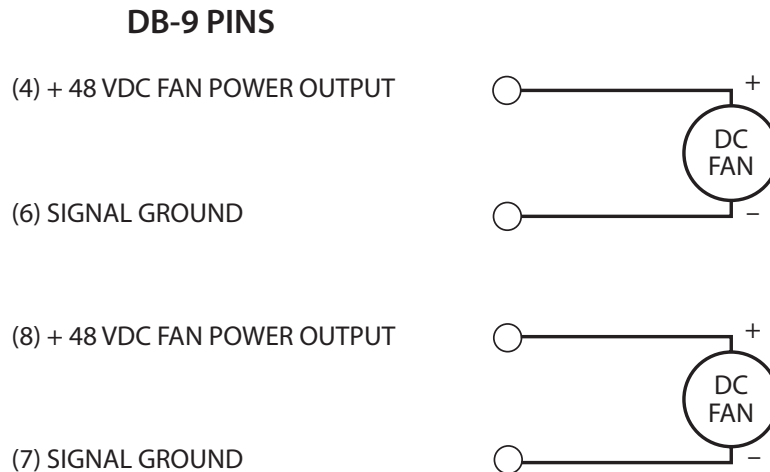

Figure 4-18 48 VDC fan connection- no speed control.

**Important Note:**

The combined current draw of **both** fans must not exceed 1.0 A to prevent tripping the internal 1.1 A self-resetting fuse.

# Technical Reference

## DB-9 I/O Connections (SA models only)

### Internal fan speed control

The side-mounted DB-9 connector on SA model lasers has internal circuitry that controls fan speed based on the laser's output power and chassis temperature. At tickle, or very low PWM duty cycles, cooling fans run at reduced speed to minimize noise; at higher PWM duty cycles, fan speed increases to match the cooling rate to power output. Fan speed is controlled by pulse width modulation (PWM) of the Fan Power Return lines (Pin 5/Pin 9) as shown in the figure below.

The following figure illustrates the connections for internal fan speed control when using customer-supplied 48 VDC cooling fans. Connect the positive (+) fan leads to Pin 4 and Pin 8, +48 VDC Fan Power Output, and connect the negative (-) fan leads to Pin 5 and Pin 9, Fan Power Return.

Some types of cooling fans are not designed for PWM control and will stall at low speeds. SYNRAD has tested Delta EFB1248SHE cooling fans with good results.

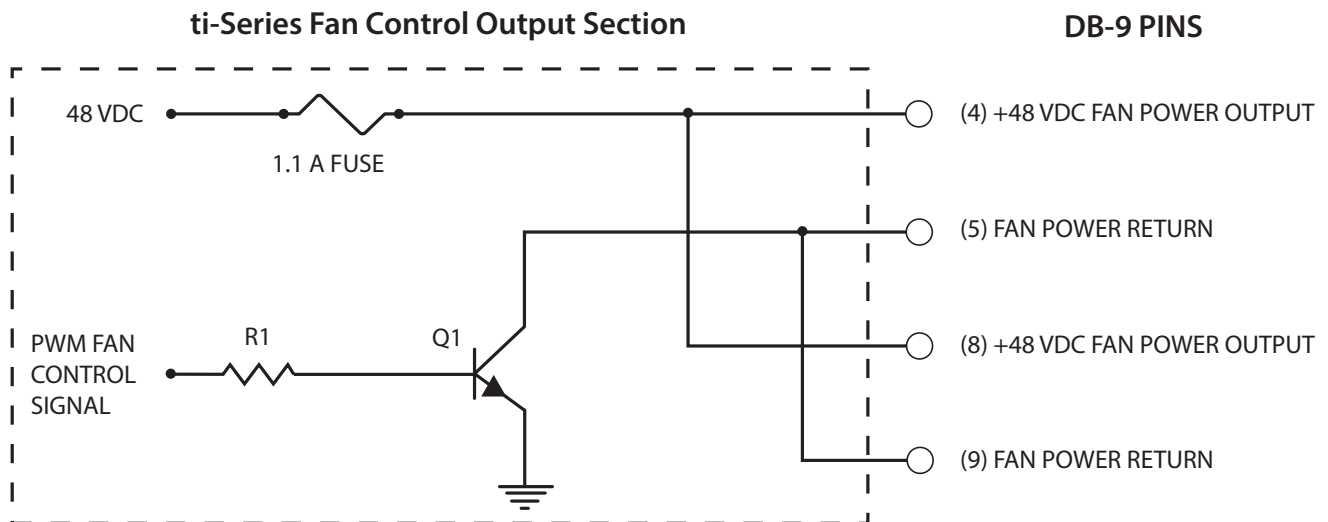

Figure 4-19 Internal fan speed control circuitry.

#### Important Note:

The combined current draw of **both (or any two)** fans must not exceed 1.0 A to prevent tripping the internal 1.1 A self-resetting fuse.

# Technical Reference

## DB-9 I/O Connections (SA models only)

### DB-9 PINS

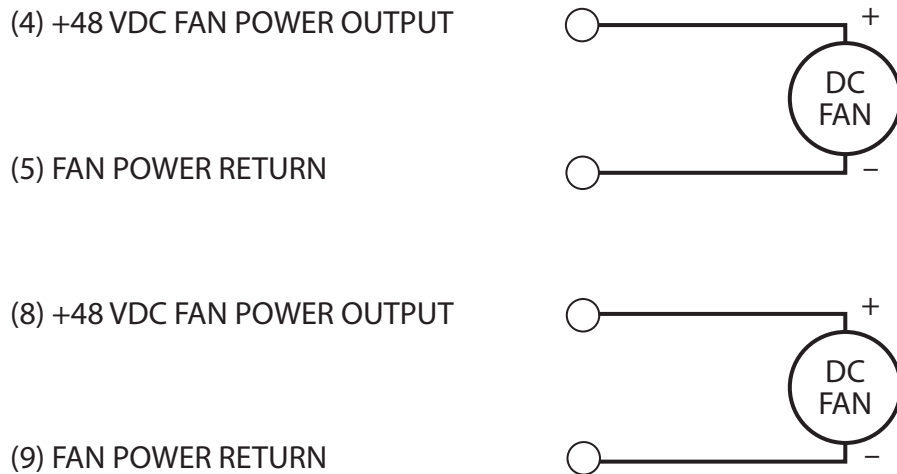

Figure 4-20 48 VDC fan connection - internal speed control.

### External fan speed control (ti80 only)

On ti80SA lasers only, the side-mounted DB-9 connector also provides an external PWM output, PWM Control Output, on Pin 1. This output provides a 5 V PWM signal for controlling the speed of PWM-enabled cooling fans based on the laser's output power and chassis temperature as shown in the figure below. At tickle, or very low PWM duty cycles, cooling fans run at reduced speed to minimize noise; at higher PWM duty cycles, fan speed increases to match the cooling rate to laser power output.

# Technical Reference

## DB-9 I/O Connections (SA models only)

The following figure illustrates the connections for external fan speed control when using customer-supplied 48 VDC cooling fans with PWM control capability. Connect the positive (+) fan leads to Pin 4 and Pin 8, +48 VDC Fan Power Output, connect the negative (-) fan leads to Pin 6 and Pin 7, Signal Ground, and connect Pin 1, PWM Control Output, to the PWM input terminal of both fans.

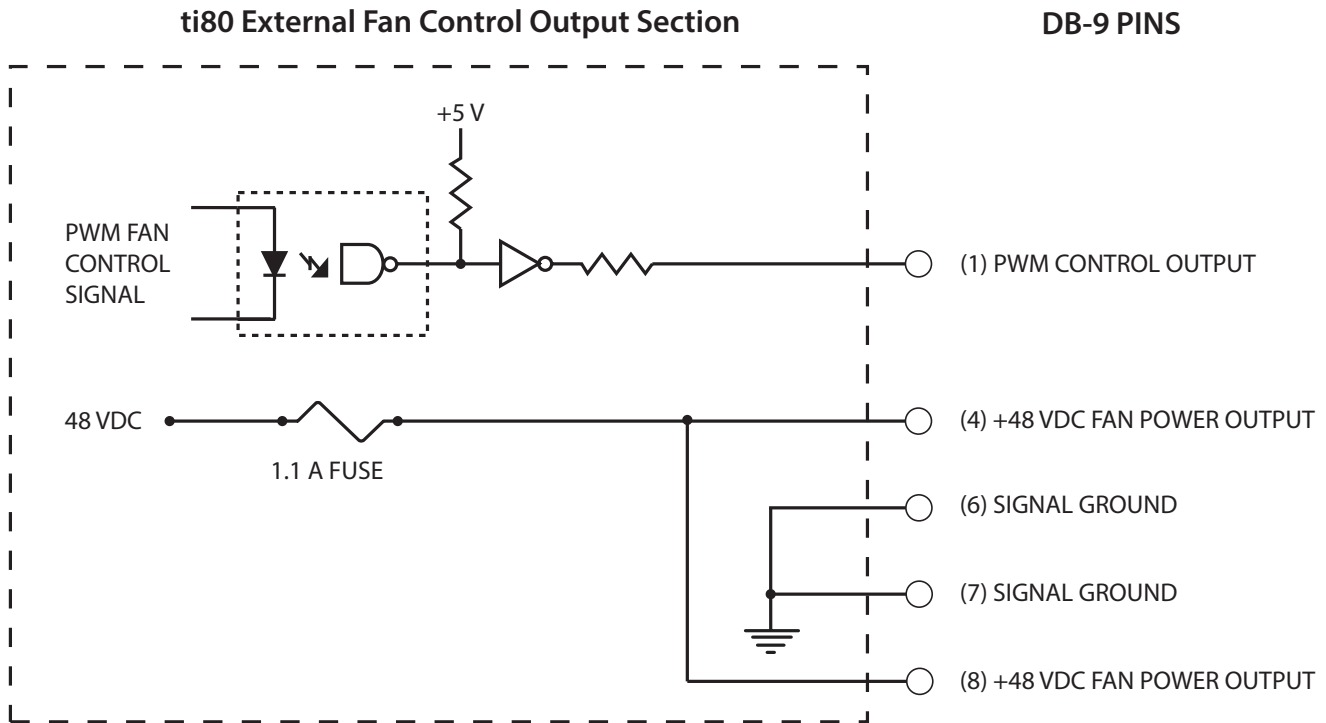

Figure 4-21 External fan speed control circuitry.

## Isolated cooling fan connections

To connect cooling fans operating at voltages other than 48 VDC or with currents greater than 1.0 A, a customer-designed isolation circuit like that shown in the figure below, could power almost any type of DC cooling fan (with a suitably sized resistor and optoisolator device) while minimizing voltage or current spikes that might damage the laser's control board.

# Technical Reference

## DB-9 I/O Connections (SA models only)

### DB-9 PINS

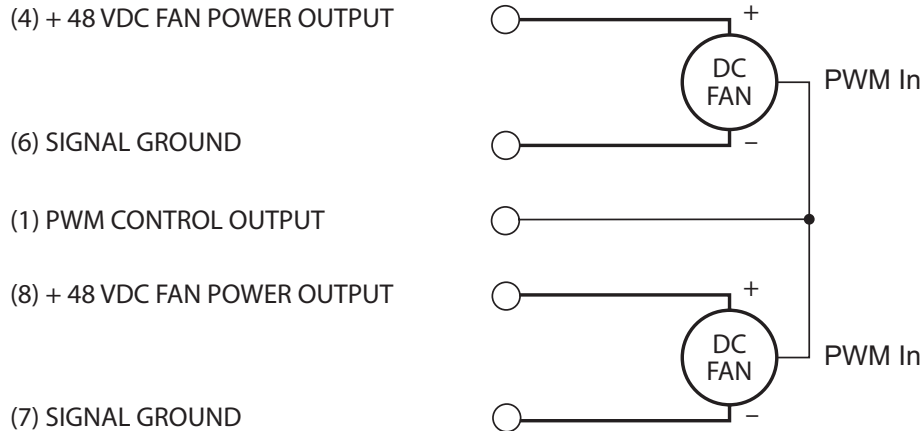

Figure 4-22 48 VDC fan connection - external speed control.

For fans with PWM control capability, follow the circuit above except connect the optoisolator returns to Pin 6 and Pin 7, Signal Ground (instead of Pins 5 and 9), and connect Pin 1, PWM Control Output, to the PWM input terminal of both fans.

### DB-9 PINS

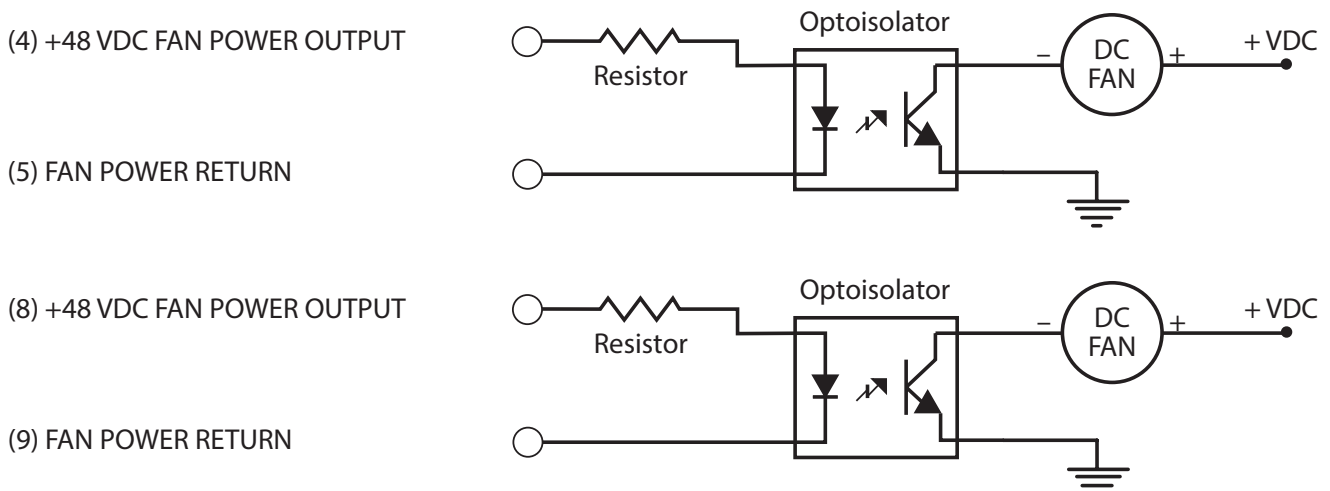

Figure 4-23 Alternate fan connections.

### Integrating ti-Series safety features

- Keyswitch functions
- Shutter functions
- Remote interlock functions

DB-15 User I/O connector allows system integrators or end-users to integrate safety features into their control system. Keyswitch, shutter, and remote interlock functions serve to enable or disable DC power to the RF drive. Without DC power, the RF driver cannot supply RF energy to the resonator, causing the CO<sub>2</sub> gas to remain in a zero-energy state. Status indicators provide users with a quick visual indication of the laser's operational status. All power to the laser's RF driver is removed whenever RDY or SHT indicators are Off (Laser Ready or Shutter Open outputs open).

### Keyswitch functions

#### Keyswitch lasers

After DC power-up or after a remote interlock fault, the Keyswitch must be toggled OFF/ON to reset the laser and enable the RDY LED, signaling that DC power is applied to the RF driver. Over temperature faults are reset by removing, then reapplying DC power after the laser has cooled.

For Keyswitch-equipped lasers in automated systems, this keyswitch/reset function is available via the Remote Reset/Start Request input on Pin 2 of the User I/O connector. To use this "remote keyswitch" functionality, first place the Keyswitch in the ON position. Then after each DC power-up cycle (or to reset a fault condition), apply a momentary voltage pulse in the range of  $\pm 5$ –24 VDC to Pin 2, the Remote Reset/Start Request input. Removing voltage allows DC power to reach the RF driver and begins a five-second delay after which lasing is enabled (RDY LED illuminates yellow). The RF driver is disabled as long as voltage is applied to Pin 2.

Your control system can monitor the laser's ready status on the User I/O connector by connecting your system's input between Pin 8, Laser Ready, and Pin 13, Output Common (see Figure 3-16). The Laser Ready output closes when the laser is enabled (RDY LED illuminated yellow), indicating that lasing is possible. The output is open (in a high-impedance state) and the RDY LED is off when lasing is disabled.

**Note:** After the Laser Ready output closes, a five-second delay occurs before lasing is enabled.

### OEM lasers

On OEM lasers, the RDY LED illuminates on DC power-up (provided that Shutter Open Request and Remote Interlock inputs are enabled) and DC power is applied to the RF driver. Over temperature faults are reset by removing and then reapplying DC power after the laser has

# Technical Reference

## Integrating Safety Features

cooled. Remote interlock faults are not latched; the RDY LED illuminates yellow as soon as the interlock circuit is closed (when the INT LED turns from red to green) and lasing is enabled immediately.

Although a Remote Reset/Start Request input is not required to reset OEM faults, it can be used to inhibit (disable) lasing. Disable the laser by applying a voltage in the range of  $\pm 5$ –24 VDC to Pin 2, the Remote Reset/Start Request input. Removing voltage allows power to reach the RF driver and lasing is enabled (RDY LED illuminates yellow) immediately. The RF driver is disabled as long as voltage is applied to Pin 2.

Your control system can monitor the laser's ready status on the User I/O connector by connecting your system's input between Pin 8, Laser Ready, and Pin 13, Output Common (see outputs driving PLC input module figure in the prior pages of this chapter).

The Laser Ready output closes when the laser is enabled (RDY LED illuminated yellow), indicating that lasing is possible. The output is open (in a high-impedance state) and the RDY LED is off when lasing is disabled.

## Shutter functions

A mechanical Shutter Switch is installed on all Keyswitch-equipped lasers. Lasing is enabled when the shutter is Open (SHT LED illuminated blue) and disabled when the shutter is Closed (SHT LED off). The SHT LED illuminates blue to indicate that DC power is applied to the RF driver.

For ti-Series OEM and Keyswitch-equipped lasers in automated systems, the shutter function is provided by the Shutter Open Request signal via Pin 10 on the User I/O connector. To use this "remote shutter", first place the Shutter Switch (if equipped) in the Open position and then apply a voltage in the range of  $\pm 5$ –24 VDC to Pin 10, Shutter Open Request. This input signal causes the SHT LED to illuminate and sends DC power to the RF driver, enabling lasing. On Keyswitch-equipped lasers, a five-second delay occurs after the input is enabled. Lasing is disabled until the manual Shutter Switch is placed in the Open position and a Shutter Open Request signal is applied to Pin 10.

Your control system can monitor the laser's shutter status on the User I/O connector by connecting your system's input between Pin 14, Shutter Open, and Pin 13, Output Common (see the outputs driving PLC input module earlier in this chapter). The Shutter Open output closes when the Shutter Switch is Open and a Shutter Open Request signal is present (SHT LED illuminated blue). The output is open (in a high-impedance state) and the SHT LED is off when the manual Shutter Switch is Closed or the Shutter Open Request signal is removed.

**Note:**  After the Shutter Open output closes, a five-second delay occurs (Keyswitch-equipped lasers only) before lasing is enabled.

### Remote interlock functions

Interlock circuits are often used to disable machinery when a shield, panel, or door is opened. Remote interlock function allows you to connect into an external remote interlock circuit and prevent lasing by removing DC power from the laser's RF driver when the circuit is electrically "open".

Lasing is enabled when a Remote Interlock signal is present (INT LED illuminated green), if RDY and SHT LEDs are illuminated, and disabled when the Remote Interlock signal is removed (INT LED red, RDY LED off). DC power is applied to the RF driver only when the INT LED is green and the RDY LED is yellow (and the SHT LED is illuminated blue). Remote interlock functionality is provided by the Remote Interlock input signal via Pin 3 on the User I/O connector.

To use the remote interlock feature, apply a voltage in the range of  $\pm 5$ –24 VDC to Pin 3, Remote Interlock. Applying an interlock signal causes the INT LED to illuminate green and sends DC power to the RF driver, which enables lasing (provided that the RDY LED is yellow and the SHT LED is blue). On Keyswitch-equipped lasers, a five-second delay occurs after the input is enabled. Removing the interlock signal removes DC power from the RF driver, causing the INT LED to turn red and the RDY LED to turn off. Lasing remains disabled until a Remote Interlock signal is reapplied to Pin 3.

Your control system can monitor the laser's remote interlock status on the User I/O connector by connecting your system's input between Pin 15, Interlock Open, and Pin 13, Output Common (see outputs driving PLC input module figure earlier in this chapter). This output is closed when remote interlock circuitry is open (INT indicator illuminated red). The output is open (in a high-impedance state) and the INT LED is green when interlock circuitry is closed.

**Note:**  After the Shutter Open output closes, a five-second delay occurs (Keyswitch-equipped lasers only) before lasing is enabled.



# Technical Reference

## ti-Series General Specifications

Table 4-5 Ti60 general specifications.

### ti-Series general specifications

Parameter			
Output Specifications	10.6 $\mu\text{m}$	10.2 $\mu\text{m}$	9.3 $\mu\text{m}$
Wavelength, $\mu\text{m}$	10.55–10.68 <sup>†</sup>	10.20–10.30	9.23–9.31
Power Output <sup>(1, 2)</sup>	60 W	60 W	60 W
Power Stability <sup>(3)</sup>	$\pm 7\%$	$\pm 7\%$	$\pm 7\%$
Mode Quality, $M^2$	$\leq 1.2$	$< 1.3$	$< 1.3$
Beam Waist Diameter, at $1/e^2$ , mm <sup>(4)</sup>	$2.0 \pm 0.3$	$2.0 \pm 0.3$	$2.0 \pm 0.3$
Beam Divergence, full angle, mrad	$< 7.0$	$< 7.0$	$< 7.0$
Ellipticity	$< 1.2$	$< 1.2$	$< 1.2$
Polarization	Linear, vert	Linear, vert	Linear, vert
Extinction Ratio	$> 100:1$	$> 100:1$	$> 100:1$
Rise Time	$< 75 \mu\text{s}$	$< 75 \mu\text{s}$	$< 75 \mu\text{s}$

#### Input Specifications

##### Power Supply

Voltage	48 V $\pm 1.0$ VDC
Maximum Current <sup>(5, 6)</sup>	18 A

##### Command Input Signal

Voltage	+3.5 to +6.7 VDC
Current	10 mA @ +6.7 VDC
Frequency <sup>(7)</sup>	DC–160 kHz
Duty Cycle	0%–100%
Logic Low State (Vmin–Vmax)	0.0 to +0.8 VDC
Logic High State (Vmin–Vmax)	+3.5 to +6.7 VDC

Cooling Specifications	(Air-cooled)	(Water-cooled)
Maximum Heat Load	900 Watts	900 Watts
Minimum Flow Rate, Air	140 CFM per fan (x2)	N/A
Static Air Pressure	0.36 in H <sub>2</sub> O	N/A
Recommended Flow Rate, Water	N/A	1.0–2.0 GPM
Maximum Coolant Pressure	N/A	$< 60$ PSI
Pressure Drop	N/A	11 PSI @ 1.5 GPM
Coolant Temperature <sup>(8)</sup>	$\leq 40$ °C, ambient	18–22 °C
Coolant Temperature Stability		$\pm 1.0$ °C

\* Specifications subject to change without notice.

† Typical. Actual wavelength range may vary from 10.2–10.8  $\mu\text{m}$ .

1 This power level is guaranteed for 12 months regardless of operating hours.

2 48 VDC input voltage to obtain guaranteed output power.

3 From cold start (guaranteed) at 95% duty cycle.

4 Measured at laser output.

# Technical Reference

## ti-Series General Specifications

Table 4-5 Ti60 general specifications (continued).

Parameter

### Environmental Specifications

Operating Ambient Temperature Range<sup>(9)</sup> ..... 15 °C–40 °C

Humidity ..... 0–95%, non-condensing

### Physical Specifications

#### ti60, water-cooled (KW, SW models)

Length ..... 22.98 in (58.4 cm)

Width ..... 5.62 in (14.3 cm)

Height ..... 5.90 in (15.0 cm)

Weight ..... 26.2 lbs (11.9 kg)

#### ti60, fan-cooled (KF, SF models)

Length ..... 22.46 in (57.1 cm)

Width ..... 7.72 in (19.6 cm)

Height ..... 5.90 in (15.0 cm)

Weight ..... 28.9 lbs (13.1 kg)

#### ti60, air-cooled (SA models)

Length ..... 22.46 in (57.1 cm)

Width ..... 6.22 in (15.8 cm)

Height ..... 5.83 in (14.8 cm)

Weight ..... 25.5 lbs (11.6 kg)

\* Specifications subject to change without notice.

5 User-supplied cooling fans on SA models may increase current load by an additional 1.0 A.

6 ti-Series lasers have no appreciable in-rush current.

7 Tested at 5 kHz.

8 Water-cooled lasers can be operated at coolant temperatures up to 30 °C (86 °F) in order to reduce problems associated with condensation; however, this may result in decreased laser performance and/or reduced laser lifetime.

9 Published specifications guaranteed at a cooling temperature of 22 °C. For ti-Series lasers, some performance degradation may occur when operated in ambient air or cooling water temperatures above 22 °C. With air-cooled lasers, output laser power typically decreases 0.5–1% per degree Celsius increase in ambient temperature.

# Technical Reference

## ti-Series General Specifications

Table 4-5 Ti80 general specifications.

Parameter			
Output Specifications	10.6 $\mu\text{m}$	10.2 $\mu\text{m}$	9.3 $\mu\text{m}$
Wavelength, $\mu\text{m}$ .....	10.55–10.68 <sup>†</sup> .....	10.20–10.30 .....	9.23–9.31
Power Output <sup>(1,2)</sup> .....	80 W .....	80 W .....	80 W
Power Stability <sup>(3)</sup> .....	$\pm 7\%$ .....	$\pm 7\%$ .....	$\pm 7\%$
Mode Quality, $M^2$ .....	$\leq 1.2$ .....	$< 1.3$ .....	$< 1.3$
Beam Waist Diameter, at $1/e^2$ , mm <sup>(4)</sup> .....	$2.0 \pm 0.3$ .....	$2.0 \pm 0.3$ .....	$2.0 \pm 0.3$
Beam Divergence, full angle, mrad ..	$< 7.0$ .....	$< 7.0$ .....	$< 7.0$
Ellipticity .....	$< 1.2$ .....	$< 1.2$ .....	$< 1.2$
Polarization .....	Linear, vert .....	Linear, vert .....	Linear, vert
Extinction Ratio .....	$> 100:1$ .....	$> 100:1$ .....	$> 100:1$
Rise Time .....	$< 75 \mu\text{s}$ .....	$< 75 \mu\text{s}$ .....	$< 75 \mu\text{s}$
<b>Input Specifications</b>			
<b>Power Supply</b>			
Voltage .....	48 V $\pm 1.0$ VDC		
Maximum Current <sup>(5,6)</sup> .....	22 A		
<b>Command Input Signal</b>			
Voltage .....	+3.5 to +6.7 VDC		
Current .....	10 mA @ +6.7 VDC		
Frequency <sup>(7)</sup> .....	DC–160 kHz		
Duty Cycle .....	0%–100%		
Logic Low State (Vmin–Vmax) .....	0.0 to +0.8 VDC		
Logic High State (Vmin–Vmax) ...	+3.5 to +6.7 VDC		
<b>Cooling Specifications</b>			
	(Air-cooled) .....	(Water-cooled)	
Maximum Heat Load .....	1200 Watts .....	1200 Watts	
Minimum Flow Rate, Air .....	190 CFM per fan ( $\times 2$ ) .....	N/A	
Static Air Pressure .....	0.70 in H <sub>2</sub> O .....	N/A	
Recommended Flow Rate, Water .....	N/A .....	1.0–2.0 GPM	
Maximum Coolant Pressure .....	N/A .....	60 PSI	
Pressure Drop .....	N/A .....	11 PSI @ 1.5 GPM	
Coolant Temperature <sup>(8)</sup> .....	$\leq 40^\circ\text{C}$ , ambient .....	18–22 $^\circ\text{C}$	
Coolant Temperature Stability .....	$\pm 1.0^\circ\text{C}$		

\* Specifications subject to change without notice.  
 † Typical. Actual wavelength range may vary from 10.2–10.8  $\mu\text{m}$ .  
 1 This power level is guaranteed for 12 months regardless of operating hours.  
 2 48 VDC input voltage to obtain guaranteed output power.  
 3 From cold start (guaranteed) at 95% duty cycle.  
 4 Measured at laser output.

# Technical Reference

## ti-Series General Specifications

Table 4-5 Ti80 general specifications (continued).

---

### Environmental Specifications

Operating Ambient Temperature Range<sup>(9)</sup> ..... 15 °C–40 °C

Humidity ..... 0–95%, non-condensing

---

### Physical Specifications

#### ti80, water-cooled (KW, SW models)

Length ..... 22.98 in (58.4 cm)

Width ..... 5.62 in (14.3 cm)

Height ..... 5.90 in (15.0 cm)

Weight ..... 26.2 lbs (11.9 kg)

---

#### ti80, fan-cooled (KF, SF models)

Length ..... 22.46 in (57.1 cm)

Width ..... 7.72 in (19.6 cm)

Height ..... 5.90 in (15.0 cm)

Weight ..... 28.9 lbs (13.1 kg)

---

#### ti80, air-cooled (SA models)

Length ..... 22.46 in (57.1 cm)

Width ..... 6.22 in (15.8 cm)

Height ..... 5.83 in (14.8 cm)

Weight ..... 25.5 lbs (11.6 kg)

---

\* Specifications subject to change without notice.

5 User-supplied cooling fans on SA models may increase current load by an additional 1.0 A.

6 ti-Series lasers have no appreciable in-rush current.

7 Tested at 5 kHz.

8 Water-cooled lasers can be operated at coolant temperatures up to 30 °C (86 °F) in order to reduce problems associated with condensation; however, this may result in decreased laser performance and/or reduced laser lifetime.

9 Published specifications guaranteed at a cooling temperature of 22 °C. For ti-Series lasers, some performance degradation may occur when operated in ambient air or cooling water temperatures above 22 °C. With air-cooled lasers, output laser power typically decreases 0.5–1% per degree Celsius increase in ambient temperature.

# Technical Reference

## ti-Series General Specifications

Table 4-5 Ti100 general specifications.

Parameter			
<b>Output Specifications</b>	10.6 $\mu\text{m}$	10.2 $\mu\text{m}$	9.3 $\mu\text{m}$
Wavelength, $\mu\text{m}$ .....	10.55–10.68 <sup>†</sup> .....	10.20–10.30 .....	9.23–9.31
Power Output <sup>(1,2)</sup> .....	100 W .....	100 W .....	100 W
Power Stability <sup>(3)</sup> .....	$\pm 7\%$ .....	$\pm 7\%$ .....	$\pm 7\%$
Mode Quality, $M^2$ .....	$\leq 1.2$ .....	$< 1.3$ .....	$< 1.3$
Beam Waist Diameter, at $1/e^2$ , mm <sup>(4)</sup> .....	$2.0 \pm 0.3$ .....	$2.0 \pm 0.3$ .....	$2.0 \pm 0.3$
Beam Divergence, full angle, mrad ..	$< 7.0$ .....	$< 7.0$ .....	$< 7.0$
Ellipticity .....	$< 1.2$ .....	$< 1.2$ .....	$< 1.2$
Polarization .....	Linear, vert .....	Linear, vert .....	Linear, vert
Extinction Ratio .....	$> 100:1$ .....	$> 100:1$ .....	$> 100:1$
Rise Time .....	$< 60 \mu\text{s}$ .....	$< 60 \mu\text{s}$ .....	$< 60 \mu\text{s}$
<b>Input Specifications</b>			
<b>Power Supply</b>			
Voltage .....	48 V $\pm 1.0$ VDC		
Maximum Current <sup>(5)</sup> .....	35 A		
<b>Command Input Signal</b>			
Voltage .....	+3.5 to +6.7 VDC		
Current .....	10 mA @ +6.7 VDC		
Frequency <sup>(6)</sup> .....	DC–160 kHz		
Duty Cycle .....	0%–100%		
Logic Low State (Vmin–Vmax) .....	0.0 to +0.8 VDC		
Logic High State (Vmin–Vmax) ..	+3.5 to +6.7 VDC		
<b>Cooling Specifications (Water-cooled)</b>			
Maximum Heat Load .....	1700 Watts		
Recommended Flow Rate, Water .....	1.0–2.0 GPM		
Maximum Coolant Pressure .....	60 PSI		
Pressure Drop .....	11 PSI @ 1.5 GPM		
Coolant Temperature <sup>(7)</sup> .....	18–22 °C		
Coolant Temperature Stability .....	$\pm 1.0$ °C		

\* Specifications subject to change without notice.

† Typical. Actual wavelength range may vary from 10.2–10.8  $\mu\text{m}$ .

1 This power level is guaranteed for 12 months regardless of operating hours.

2 48 VDC input voltage to obtain guaranteed output power.

3 From cold start (guaranteed) at 95% duty cycle.

4 Measured at laser output.

5 ti-Series lasers have no appreciable in-rush current.

# Technical Reference

## ti-Series General Specifications

Table 4-5 Ti100 general specifications (continued).

Parameter	
<b>Environmental Specifications</b>	
Operating Ambient Temperature Range <sup>(8)</sup>	15 °C–40 °C
Humidity	0–95%, non-condensing
<b>Physical Specifications</b>	
ti100, water-cooled (KW, SW models)	
Length	22.98 in (58.4 cm)
Width	5.62 in (14.3 cm)
Height	5.90 in (15.0 cm)
Weight	26.2 lbs (11.9 kg)

\* Specifications subject to change without notice.  
6 Tested at 5 kHz.  
7 Water-cooled lasers can be operated at coolant temperatures up to 30 °C (86 °F) in order to reduce problems associated with condensation; however, this may result in decreased laser performance and/or reduced laser lifetime.  
8 Published specifications guaranteed at a cooling temperature of 22 °C. For ti-Series lasers, some performance degradation may occur when operated in ambient air or cooling water temperatures above 22 °C.

# Technical Reference

## ti-Series Drawings

### Technical Drawings

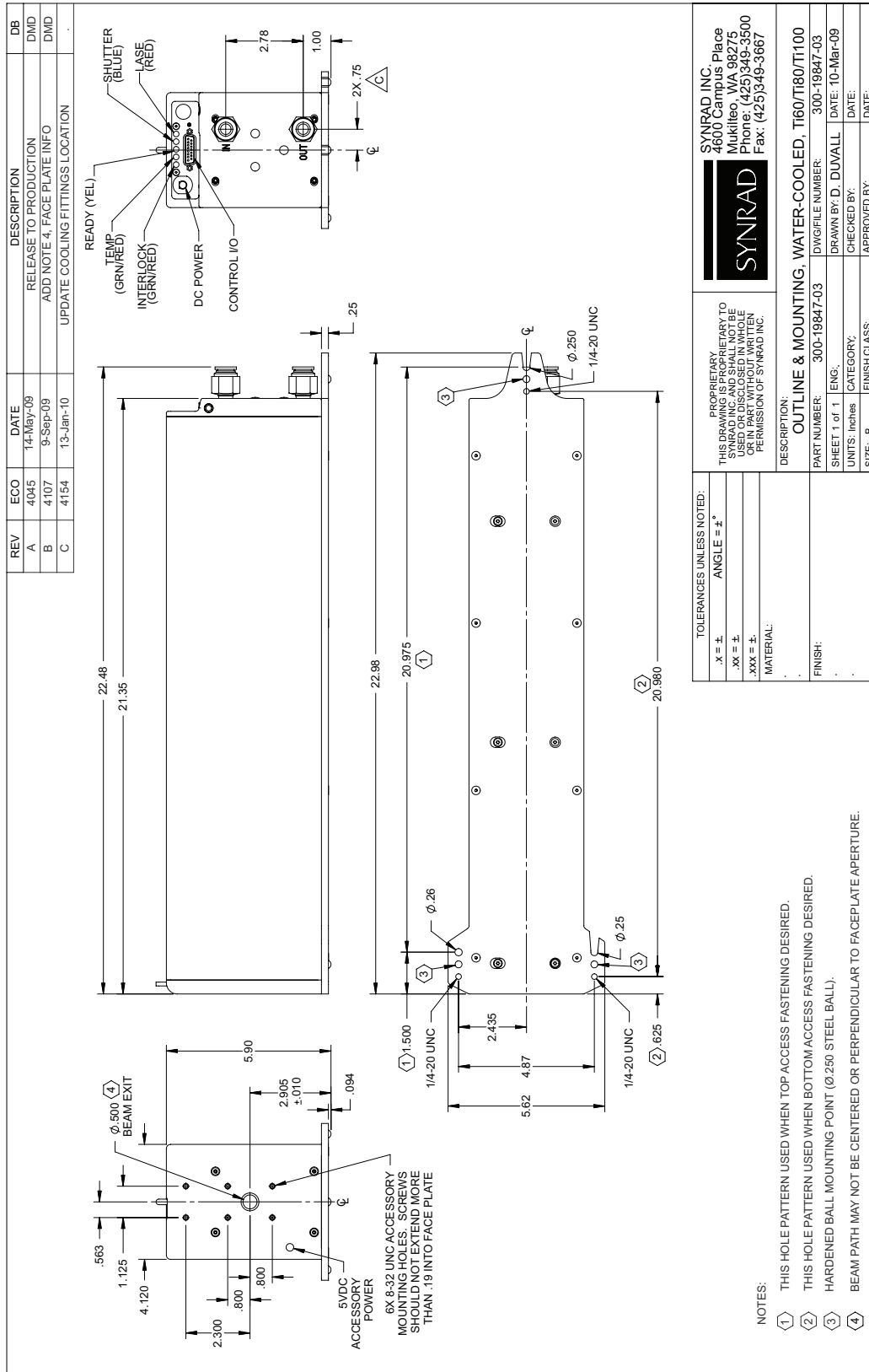

Figure 4-24 Water-cooled ti60/ti80/ti100 package outline and mounting dimensions.

# Technical Reference

## ti-Series Drawings

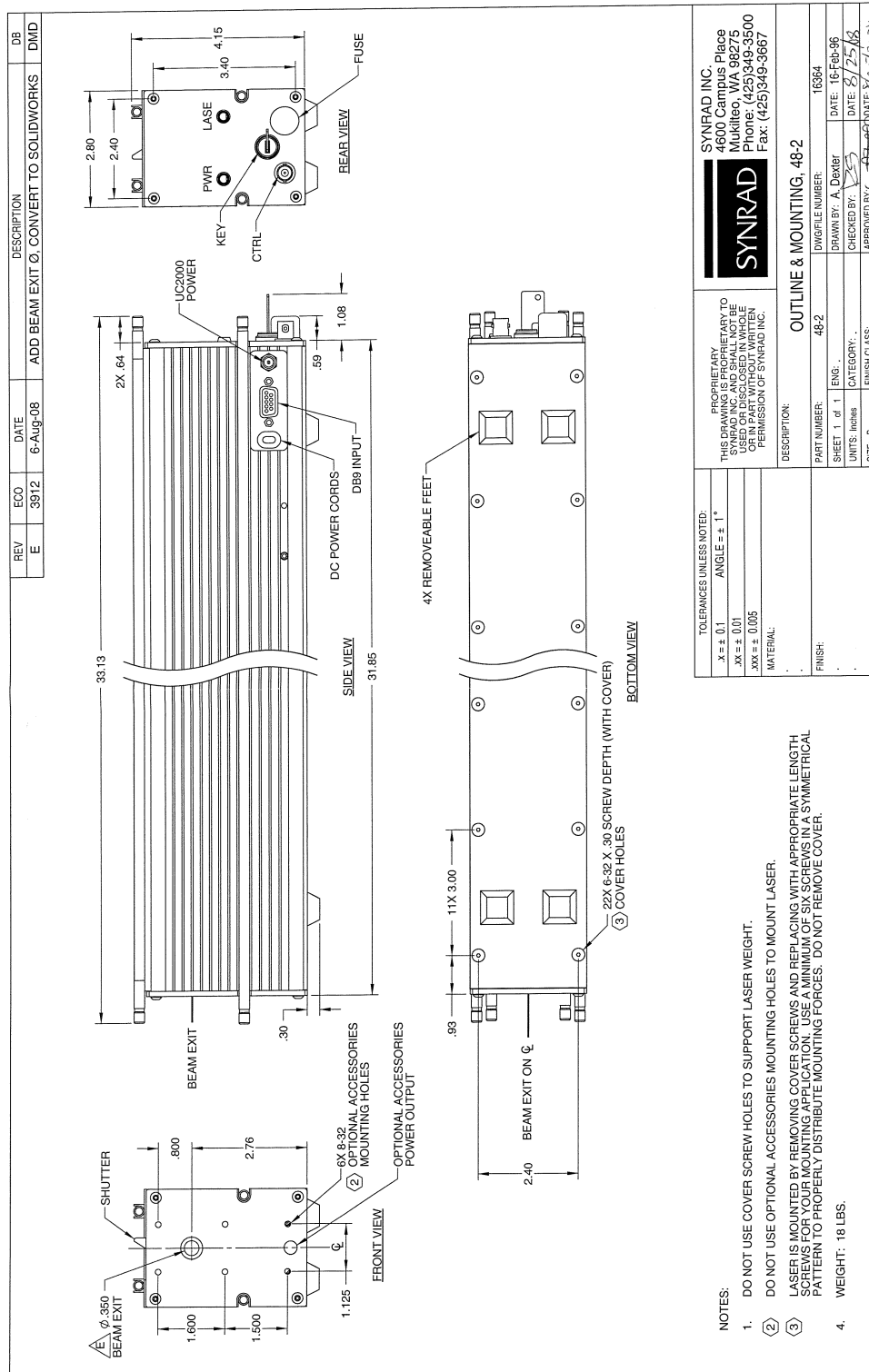

Figure 4-25 Water-cooled ti60/ti80/ti100 package outline and mounting dimensions.



# Technical Reference

## ti-Series Drawings

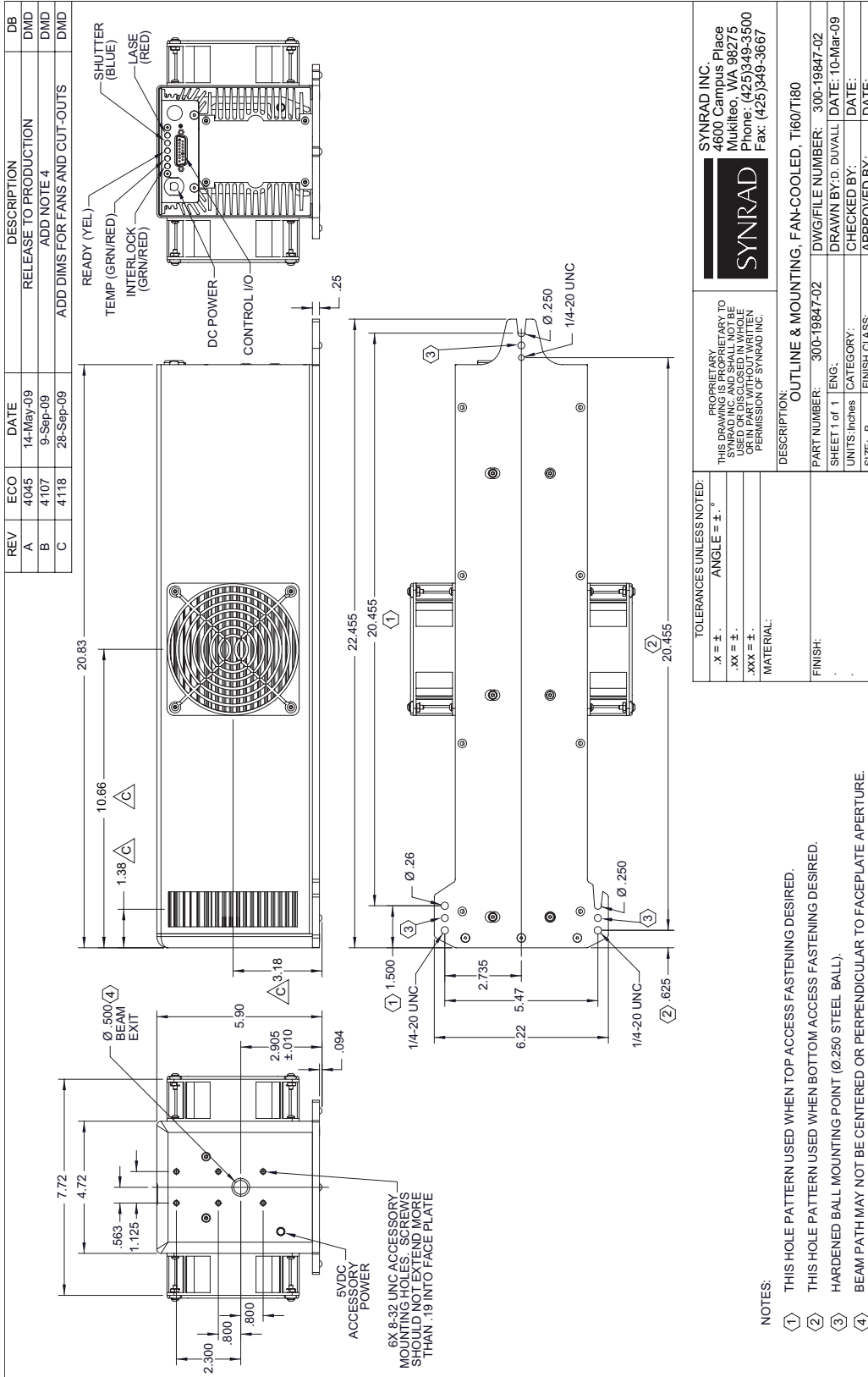

Figure 4-26 Fan-cooled ti60/ti80 package outline and mounting dimensions.

# Technical Reference

## ti-Series Drawings

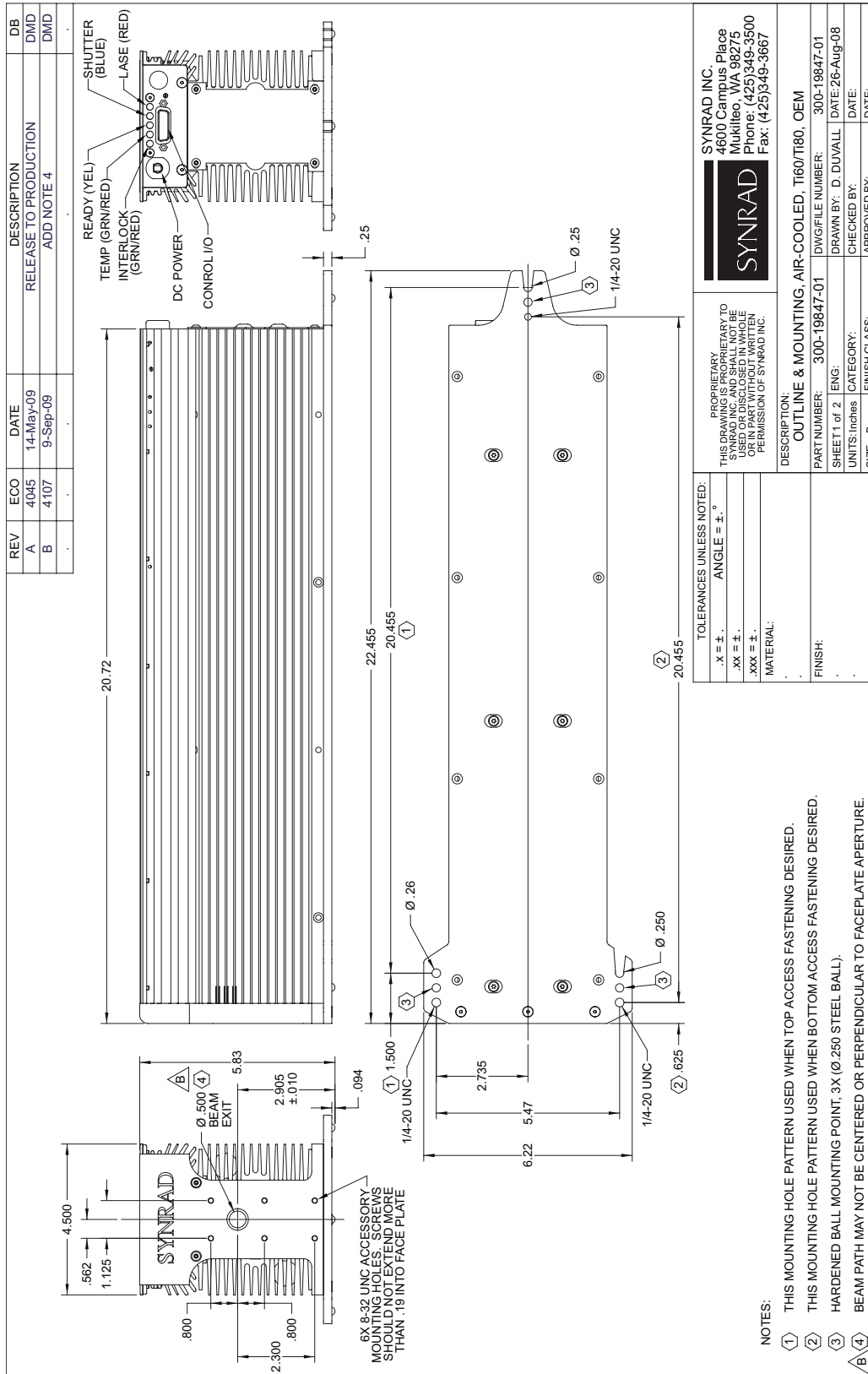

Figure 4-27 OEM air-cooled ti60/ti80 (SA model) package outline and mounting dimensions, 1 of 2.

# Technical Reference

## ti-Series Drawings

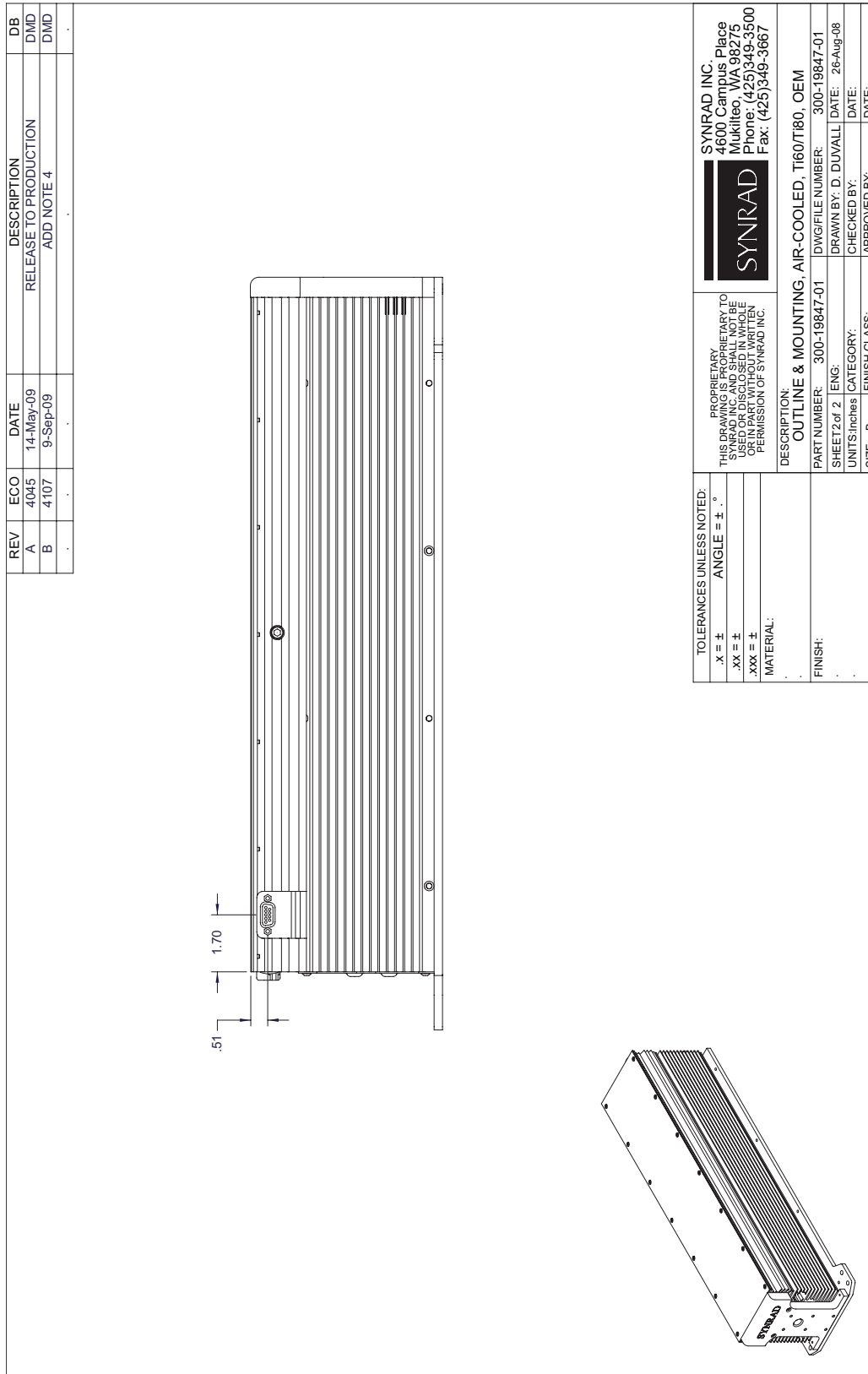

Figure 4-28 OEM air-cooled ti60/ti80 (SA model) package outline and mounting dimensions, sheet 2 of 2.

# Technical Reference

## ti-Series Drawings

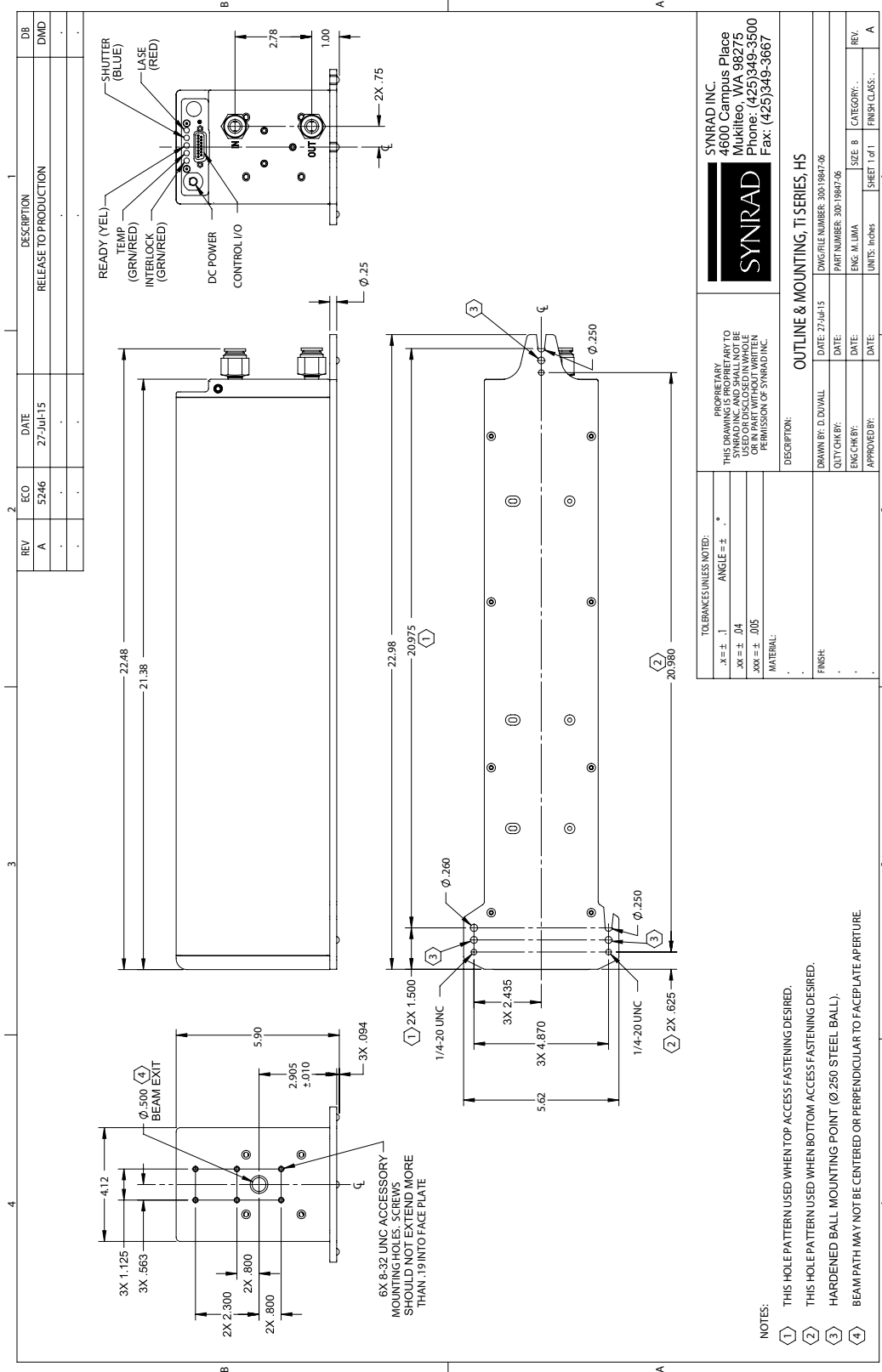

Figure 4-27 Ti-Series HS Outline and Mounting.

# Technical Reference

## ti-Series Drawings

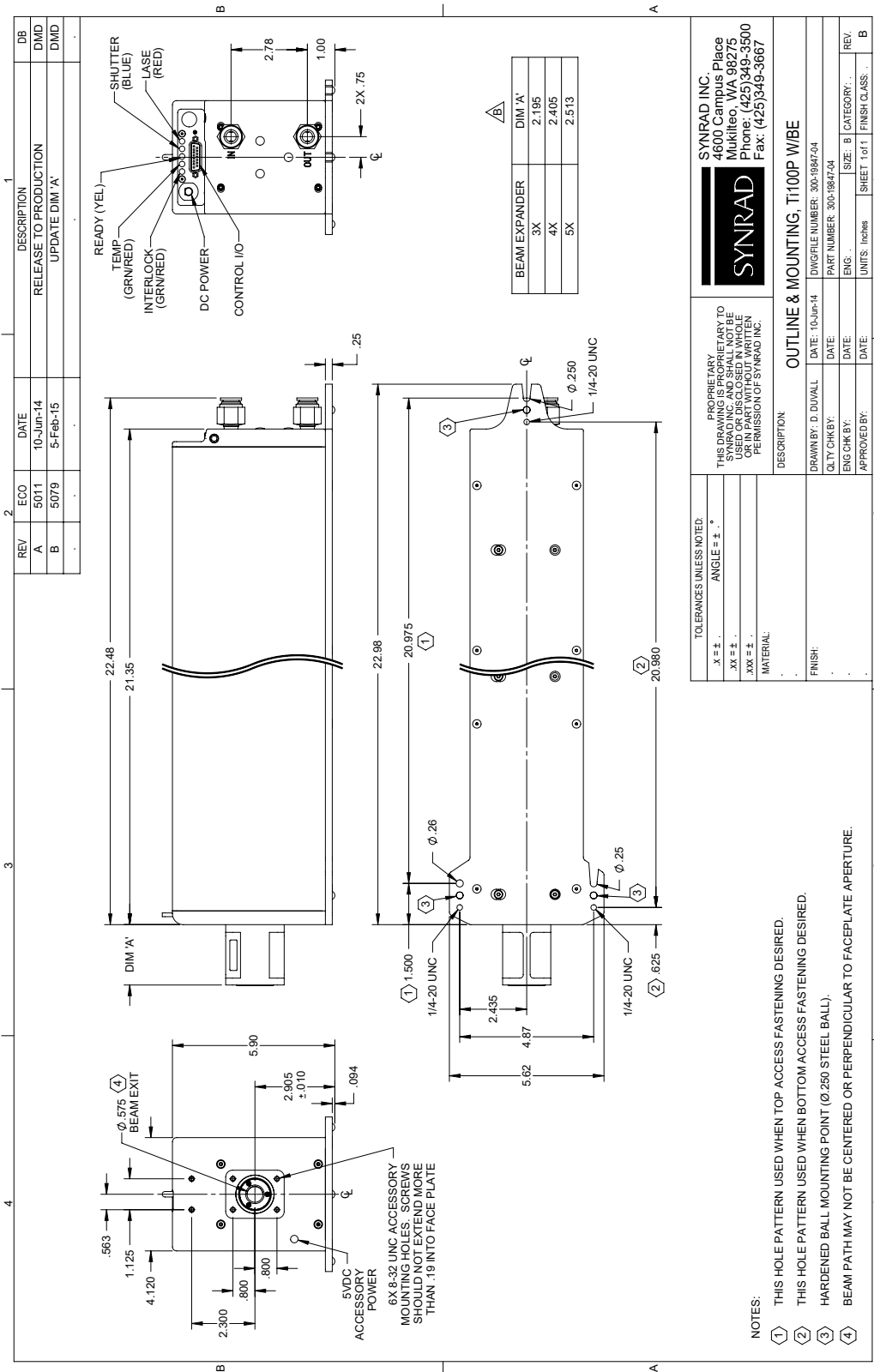

Figure 4-28 Ti-100p Outline and Mounting.

# Technical Reference

## ti-Series Drawings

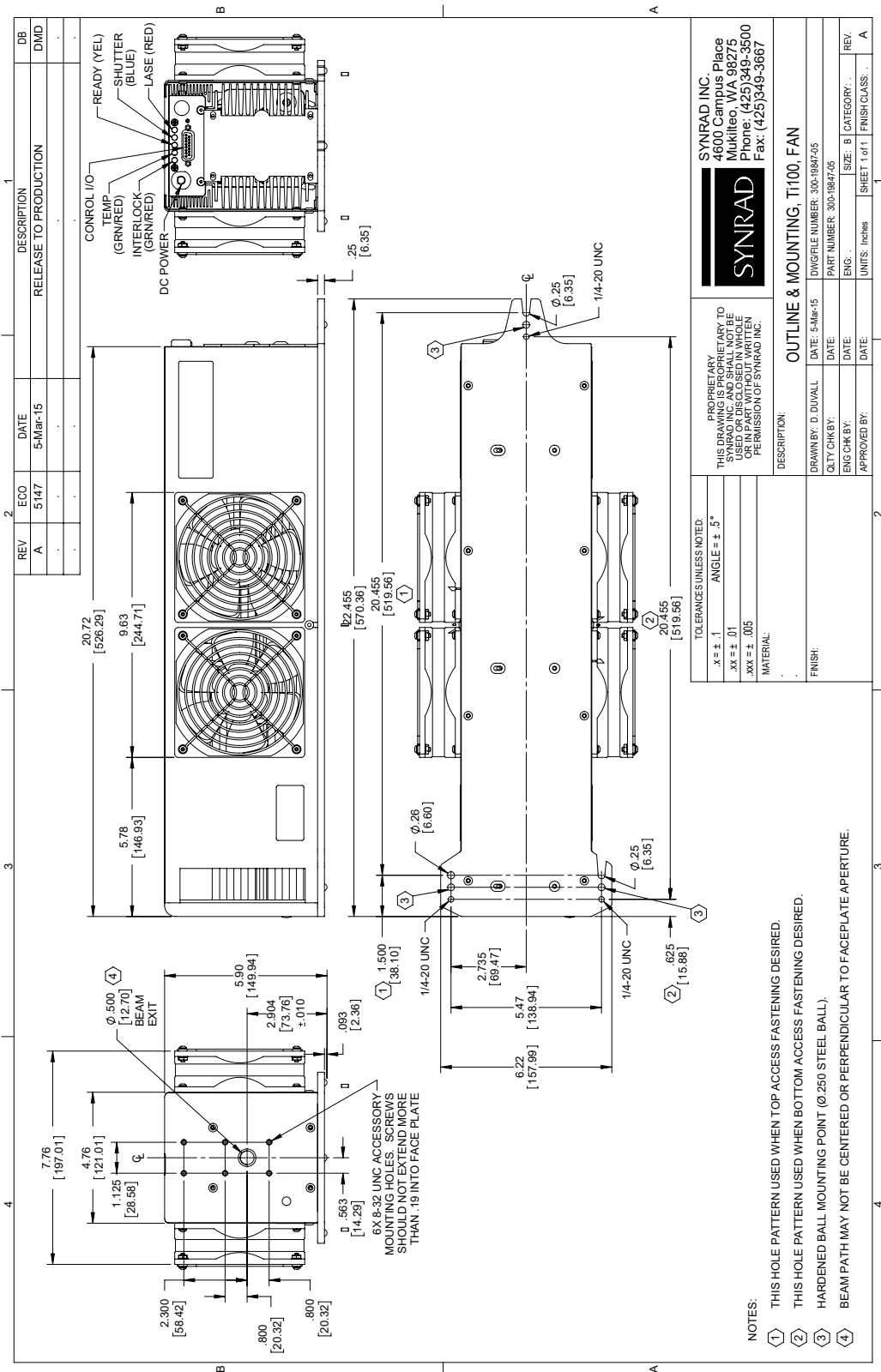

Figure 4-29 Ti-100 Fan Outline and Mounting.

# Technical Reference

## ti-Series Drawings

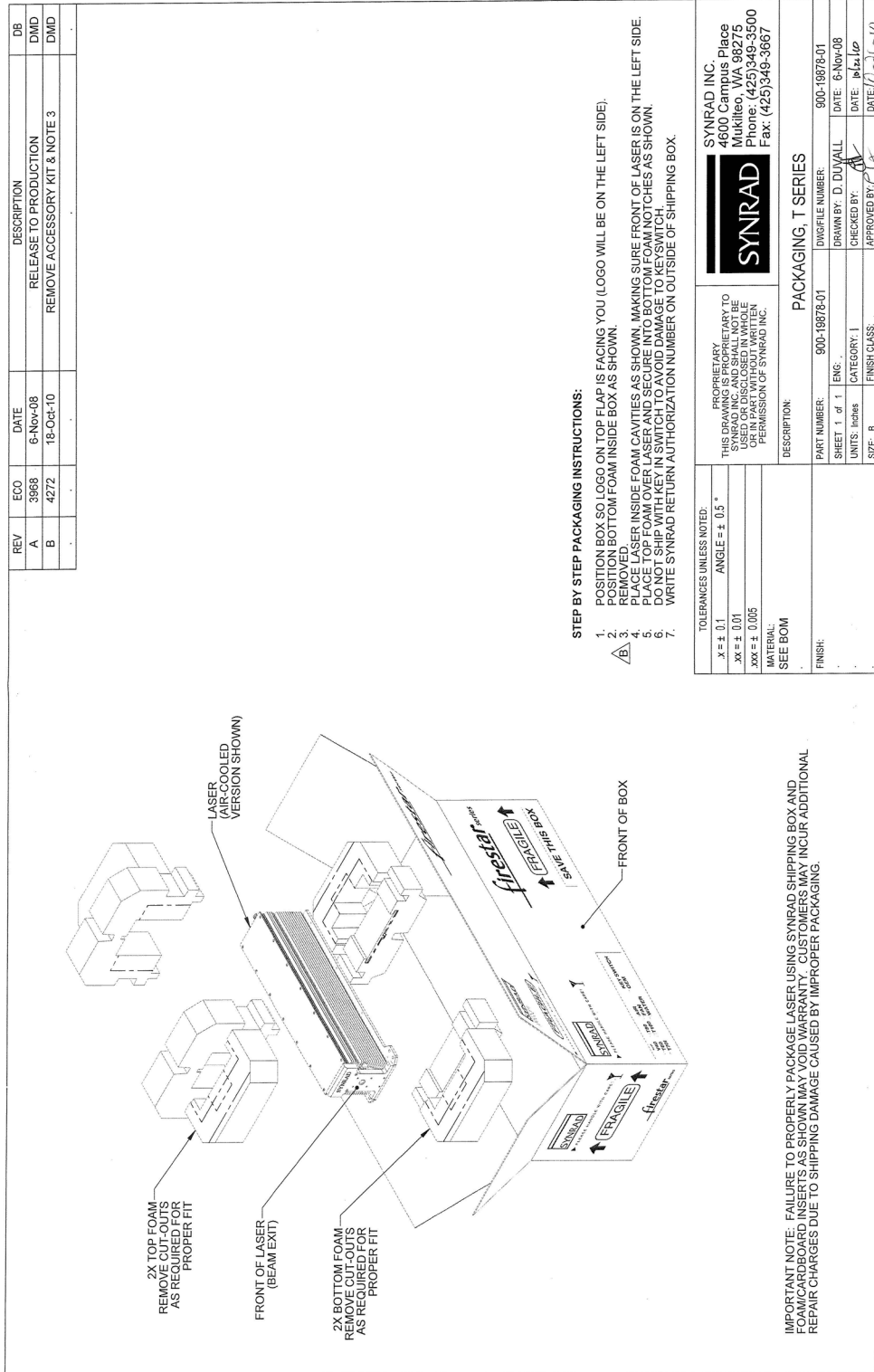

Figure 4-29 ti-Series packaging instructions.

# Index

## Symbols

- +5 VDC , 100, 58
  - signal description, 51
- +24 VDC 58, 60
  - signal description, 51

## A

- American National Standards Institute (ANSI) 18
- Assist gas purity
  - specifications, 37, 39
- Aux. DC Power Ground , 100, 50
  - signal description, 51
- Auxiliary DC power 51
  - +5 VDC 51, 58
  - +24 VDC 51, 58, 60
  - Aux. DC Power Ground, 51

## B

- Beam characteristics 37

## C

- Caution
  - condensation, 6, 15, 30, 35, 50, 88, 90, 92, 93
  - User I/O connector, 50
- CDRH 23
- Chiller
  - flow rate, 101
  - temperature setpoint, , 40
- Class IV safety features 26
- Code of Federal Regulations (CFR) 23, 24
- Command signal
  - PWM duty cycle, 43
  - signal amplitude, 43
- Condensation damage 88
- Controlling laser power
  - control signals, 42
- Control signals 42
  - Tickle pulse, 42
- Cooling fans
  - clearance, 101
- Customer Service 9

## D

- Daily inspections 88
- Danger
  - laser radiation, 15, 16, 17, 18, 30, 43, 45, 47, 54, 87, 89, 98, 103
  - OEM faults, 98
- DC power
  - +5 VDC 51
  - +24 VDC 51
  - Aux. DC Power Ground, 51
- DC Power cable 88
- Disabling Firestar 88

## E

- EU

## F

- Flowchart
  - laser start-up, 94
- Focusing optics 38
- Food and Drug Administration (FDA) 23

## H

- Hazard information 16
  - label locations, 20, 21, 22
  - terminology, 16

## I

- Input circuit
  - sample diagrams, 58
- Input Common , 49, 59
- Input signals
  - Input Common, , 49, 59
  - PWM Input, 53
  - PWM Return, 48, 52
  - Remote Interlock, , 52, 58, 69, 71, 53
  - Remote Reset/Start Request , 48, 52
  - Shutter Open Request, , 49, 53, 69, 70, 49
- Inspections
  - daily, 88
- Interlock Open output , 50, 56

## L

- Label locations 20, 21, 22
- Lase (LASE) indicator 33, 49, 55
- Laser Active output 49
- Laser Institute of America (LIA) 19
- Laser Ready output 49, 55, 56, 69, 70
- Laser tube 36

## M

- Maintenance
  - daily inspections, 88
  - disabling Firestar, 88
  - storage/shipping, 89
- MSDS 91

## O

- Occupational Safety and Health Administration (OSHA) 19
- Operating modes
  - analog current control, 45
  - analog voltage control, 45
  - external control, 45
- Optical resonator
- Output Common 50, 56, 69, 70
- Output signals



# Index

Interlock Open, , 50, 56  
Laser Active, 49  
Laser ready, 49, 55, 56, 69, 70  
Output Common, 50, 56, 69, 70  
Over Temperature, 49  
Shutter Open, 49, 55, 56  
Over Temperature output 49

## P

PWM Input signal 43, 46, 53  
specifications, 55  
PWM Return signal 43, 46, 48, 52

## Q

Quick Start Plug 100, 102

## R

Ready (RDY) indicator 48, 49, 52, 56, 69, 71  
Reference materials 9  
Remote Interlock input , 52, 58, 69, 71, 53  
specifications, 55  
Remote Interlock (INT) indicator 50, 56, 70, 71  
Remote Reset/Start Request input , 48, 52  
specifications, 55  
RoHS 25

## S

Sales and Applications 9  
Sample I/O circuits 58  
Shutter Open output 49, 55, 56  
Shutter Open Request input , 49, 53, 69, 70, 49  
specifications, 55  
Shutter (SHT) indicator 33, 69  
Specifications  
assist gas purity, 37, 39  
Storage/shipping 89

## T

Technical Support 9  
Temp (TMP) indicator , 49, 56  
Trademark information 7  
Troubleshooting 90  
operational flowchart, 94

## U

UC-2000 Laser Controller 45  
User I/O connections  
Input/Output signals, 48  
summary, 48  
User I/O connector , 33, 43, 46, 102, 51, 69, 70

## W

Warning  
laser output, 43  
Warranty information 8

# Index

# Appendix



## Appendix

- Stabilized ti Series laser addenda for the Operators Manual ver 1.7.
- ti100 fan cooled laser installation and operation addenda for the Operators Manual version 1.7.
- ti100p pulsed laser addenda for the ti-Series Operators Manual version 1.7.

# Appendix

## Stabilized ti Series laser addenda

High Stability laser (ti-60w, ti-80w, ti-100w-HS): Except as noted here, refer to the ti-Series Operator's Manual for additional installation, integration, and operation information. Front panel for ti-60w, ti-80w, and ti-100w models: The High Stability (HS) laser does not provide DP power.

### Physical Specifications:

ti-60w, ti-80w, ti-100w (HS), water-cooled (SW models)

Length .....	21.4 in (544 mm)
Width .....	4.1 in (104 mm)
Height .....	5.9 in (150 mm)
Weight .....	42 lbs (19 kg)

### Stability Specifications:

ti-60W-HS, ti-80HS, ti-100HS, water-cooled (SW models)

Stabilized Laser Power (typical) Stability.....	$\pm 4\%$ (cold) .....	$\pm 4\%$ (cold).....	$\pm 4\%$ (cold)
After three (3) min (guaranteed).....	$\pm 2\%$ .....	$\pm 2\%$ .....	$\pm 2\%$

## ti100 fan cooled laser installation and operation addenda

Except as noted here, refer to the ti-Series Operator's Manual located on our web site for installation, integration, and operation information.

### Operation:

Front Panel: The ti100 fan-cooled laser does not provide a DP Power connector.

### Technical Reference:

General Specifications: Physical Specifications.

Length .....	22.46 in (57.0 cm)
Width .....	7.76 in (19.7 cm)
Height .....	5.9 in (15.0 cm)
Weight .....	27.0 lbs (12.3 kg)

# Appendix

## ti100p pulsed laser addenda

ti100p that differs from standard ti-Series lasers: Otherwise refer to the ti-Series Operator's Manual located on our web site for installation, integration, and operation information.

- The ti100p is currently available in 9.3  $\mu\text{m}$  and 10.6  $\mu\text{m}$  wavelengths.
- The ti100p is a pulsed laser; therefore, the maximum PWM duty cycle is limited to 50%.
- Maximum Pulse Repetition Frequency (PRF) is 100 kHz.
- Pulse width is limited to 500  $\mu\text{s}$  maximum.

The ti100p is shipped with a beam expander mounted and aligned to the faceplate. Available expansion ratios are 3X, 4X, and 5X. Beam diameter (1/e<sup>2</sup>) at the beam expander output is shown in the table below:

Expander Ratio	Beam Diameter	Beam Divergence
3X	6.6 mm	~2.3 mrad
4X	8.8 mm	~1.8 mrad
5X	11.0 mm	~1.4 mrad

**Important Note:**



Do not apply a tickle signal. Do not use a UC-2000 Controller or other PWM signal source that generates a tickle signal. Applying a tickle signal to the ti100p may interfere with its pulsing performance.

## The minimum power supply requirement for the ti100p laser is:

Voltage: 48 V  $\pm$  1.0 VDC

Current: 35 A (50 A peak for < 500  $\mu\text{s}$ )