

p250 OEM Series Operator's Manual



SYNRAD[®]

A Novanta Company

4600 Campus Place
Mukilteo, WA 98275
1.800.SYNRAD1
tel 1.425.349.3500
fax 1.425.349.3667
e-mail synrad@synrad.com
web www.synrad.com

Pulstar® p250 Operator's Manual

Version 1.9

SYNRAD® is a registered trademark of Novanta Corporation. ©Novanta Corporation 2019. All Rights Reserved. No reproduction without written authorization.

DATE: July 2019

Table of contents

Introduction 1

- Chapter Introduction Summary..... 5
- Trademark & Copyright information 6
- Sales and Applications 8
- Customer Service 8
- Technical Support 8
- Reference materials 8
- EU headquarters 9
- Guidelines & Content..... 10
- Unpacking/packing, Storage/shipping, Mounting, Connecting and Cooling..... 10
- Contents Description..... 10
- Nomenclature..... 13

Laser Safety 2

- Laser Safety Introduction 15
- Hazard Information 16
- Terms..... 16
- General hazards 17
- Disposal 19
- Other hazards 19
- Additional laser safety information 19
- P250 label locations 20
- Agency compliance 21
- Center for Devices and Radiological Health (CDRH) requirements..... 21
- European Union (EU) requirements..... 23

Operation 3

- Chapter Introduction 27
- Controls and indicators 28
- OEM p250 front panel..... 28
- OEM p250 rear panel..... 29
- Start-up and pulsed operation 30
- Initial Start-up..... 30

Technical Reference 4

- Chapter Introduction 31
- Technical overview 32
- Laser design 32
- Beam delivery optics and setup..... 35
- Focusing optics 36
- RF power supply 37
- Controlling laser power..... 41
- Control signals..... 41

Table of contents

Technical Reference 4

- Operation modes 42
- User I/O connection summary..... 54
- User I/O connections..... 54
- Input/output signals 56
- Sample I/O circuits 64
- DC power cables 68
- DC power cables 68
- Pulstar p250 web interface 69
- Accessing the p250 web page..... 69
- Set your computer’s static IP address 69
- Set your computer’s static IP address continued..... 70
- Event log page layout..... 73
- Alternate Ethernet connection..... 74
- Changing the p250’s IP address 74
- Pulstar p250 firmware upgrade..... 75
- Required materials/equipment..... 75
- Firmware upgrade procedure..... 75
- Integrating Pulstar safety features 81
- Key-switch functions..... 81
- Shutter functions..... 82
- Remote interlock functions 82
- Pulstar p250 General Specifications 83
- Pulstar p250 Outline & Mounting Drawings..... 85

Maintenance & Troubleshooting 5

- Chapter Introduction 88
- Maintenance 89
- Disabling the p250 laser 89
- Daily inspections 89
- Storage/shipping..... 90
- Cleaning optical components 90
- Cleaning guidelines..... 91
- Required cleaning materials..... 91
- Cleaning optics 91
- Troubleshooting 93
- Operational flowchart 94
- Status LED’s..... 95
- Troubleshooting Status LED’s 96

Index

- Index 103

Introduction

1

Chapter Introduction Summary

- Pulstar™ Trademark, copyright, contact (service & support) information
- Pulstar nomenclature

Important Note:  This Operation Manual explains operation activities related to Pulstar p250 lasers. If you cannot operate the unit using the information described in this manual, contact SYNRAD® (+1.425.349.3500) or an authorized SYNRAD Distributor.

Lift the laser only by the mounting feet or baseplate. Do not lift or support the laser by its cooling fittings.

Please reference the [Quick Start Guide](#) for unpacking, mounting, and connecting.

Failure to properly package the laser using SYNRAD shipping box and foam/cardboard inserts as shown in Packaging Instructions may void the warranty. Customers may incur additional repair charges due to shipping damage caused by improper packaging.

Before beginning any maintenance or inspections of your p250 laser, be sure to completely disable the laser by disconnecting the DC Power cable (or cables) from the rear of the laser.

Caution **Possible** **Equipment** **Damage**



A **risk of exposure** to toxic elements may result when certain optical or beam delivery components are damaged. In the event of damage to laser, marking head, or beam delivery optics, contact SYNRAD, or the optics manufacturer for handling instructions.

If you **operate your laser in dirty or dusty environments**, contact SYNRAD about the risks of doing so and precautions you can take to increase the longevity of your laser, marking head, and associated optical components.

Warning **Serious** **personal** **injury**



Remote interlock faults are not latched on OEM lasers. Clearing the fault condition re-enables the RDY indicator and the laser will fire immediately provided the SHT indicator is lit and a PWM Command signal is applied.

Because exposure to CO₂ laser radiation in the (9-11) μm range can inflict severe corneal injuries and seriously burn human tissue, the OEM or System Integrator must ensure that appropriate safeguards are in place to prevent unintended lasing.

Introduction

Introduction Summary (Continued):

Warning
Serious
personal
injury



A risk of exposure to toxic elements may result when certain optical or beam delivery components are damaged. In the event of damage to laser, marking head, or beam delivery optics, contact SYNRAD, or the optics manufacturer for handling instructions.

Trademark & Copyright information

SYNRAD® and Pulstar™ are registered trademarks of SYNRAD.

All other trademarks or registered trademarks are the property of their respective owners.

2019 by SYNRAD.
All rights reserved.

Introduction

Warranty information

This is to certify that Pulstar™ p250 lasers are guaranteed by SYNRAD® to be free of all defects in materials and workmanship for a period of two years from the date of shipment. This warranty does not apply to any defect caused by negligence, misuse (including environmental factors), accident, alteration, or improper maintenance. This includes, but is not limited to, damage due to corrosion, condensation, or failing to supply properly conditioned purge gas.

We request that you examine each shipment within 10 days of receipt and inform SYNRAD of any shortage or damage. If no discrepancies are reported, SYNRAD shall assume the shipment was delivered complete and defect-free.

If, within two years from the date of shipment, any part of the Pulstar p250 laser should fail to operate, contact the SYNRAD Customer Service department at 1.800.SYNRAD1 (outside the U.S. call 1.425.349.3500) and report the problem. When calling for support, please be prepared to provide the date of shipment, model number and serial number of the unit, and a brief description of the problem. When returning a unit for service, a Return Authorization (RA) number is required; this number must be clearly marked on the outside of the shipping container in order for the unit to be properly processed. If replacement parts are sent to you, then you are required to send the failed parts back to SYNRAD for evaluation unless otherwise instructed.

If your Pulstar p250 laser fails within the first 45 days after shipment, SYNRAD will pay all shipping charges to and from SYNRAD when shipped as specified by SYNRAD Customer Service. After the first 45 days, SYNRAD will continue to pay for the costs of shipping the repaired unit or replacement parts back to the customer from SYNRAD. The customer, however, will be responsible for shipping charges incurred when sending the failed unit or parts back to SYNRAD or a SYNRAD Authorized Distributor. In order to maintain your product warranty and to ensure the safe and efficient operation of your Pulstar p250 laser, only authorized SYNRAD replacement parts can be used. This warranty is void if any parts other than those provided by SYNRAD are used.

SYNRAD and SYNRAD Authorized Distributors have the sole authority to make warranty statements regarding SYNRAD products. SYNRAD and its Authorized Distributors neither assumes nor authorizes any representative or other person to assume for us any other warranties in connection with the sale, service, or shipment of our products. SYNRAD reserves the right to make changes and improvements in the design of our products at any time without incurring any obligation to make equivalent changes in products previously manufactured or shipped. Buyer agrees to hold SYNRAD harmless from any and all damages, costs, and expenses relating to any claim arising from the design, manufacture, or use of the product, or arising from a claim that such product furnished buyer by SYNRAD, or the use thereof, infringes upon any Patent, foreign or domestic.

Introduction

Service & support information

SYNRAD® worldwide headquarters are located north of Seattle in Mukilteo, Washington. U.S.A.
Our mailing address is:

SYNRAD
4600 Campus Place
Mukilteo, WA 98275
U.S.A.

Phone us at: 1.800.SYNRAD1 (1.800.796.7231)

Outside the U.S.: +1.425.349.3500

Fax: +1.425.349.3667

web: www.synrad.com

E-mail: synrad@synrad.com

Sales and Applications

SYNRAD Regional Sales Managers work with customers to identify and develop the best CO₂ laser solution for a given application. Because they are familiar with you and your laser application, use them as a first point of contact when questions arise. Regional Sales Managers also serve as the liaison between you and our Applications Lab in processing material samples per your specifications. To speak to the Regional Sales Manager in your area, call SYNRAD at 1.800.SYNRAD1.

Customer Service

For assistance with order or delivery status, service status, or to obtain a Return Authorization (RA) number, contact SYNRAD at 1.800.SYNRAD1 and ask to speak to a Customer Service representative, or you can email us by sending a message to customercare@synrad.com.

Technical Support

SYNRAD Regional Sales Managers are able to answer many technical questions regarding the installation, use, troubleshooting, and maintenance of our products. In some cases, they may transfer your call to a Laser, Marking Head, or Software Support Specialist. You may also e-mail questions to the Technical Support Group by sending your message to customercare@synrad.com.

Reference materials

Your Regional Sales Manager can provide reference materials including Outline & Mounting drawings, Operator's Manuals, Technical Bulletins, and Application Newsletters. Most of these materials are also available directly from SYNRAD web site at <http://www.synrad.com>.

Introduction

EU headquarters

For assistance in Europe, contact SYNRAD® European subsidiary, Synrad Europe, at:

©Novanta Distribution (USD) GmbH
Parkring 57-59
85748 Garching bei München, Germany

Phone: +49-89-31707-0

web: www.synrad.com

e-mail: EMEA-service@novanta.com

Introduction

Guidelines & Content

Refer to the drawings, located in the technical reference chapter, when installing and operating your Pulstar™ p250 laser. Also reference the [p250 quick start guide](#) located on our website.

- Unpacking/Packing, Storage/Shipping, Mounting, Connecting, Cooling, Contents
- p250 nomenclature/features

Unpacking/packing, Storage/shipping, Mounting, Connecting and Cooling

SYNRAD® recommends saving all of the laser's original packaging. This specially designed packaging will protect the laser from damage during storage, relocation and/or shipping. Reference the drawings in the technical references section of this manual and the Quick Start Guide Series at Synrad.com for re-packaging p250 laser.

See the drawings located on our website Synrad.com, or in the technical reference chapter in this operation manual mounting sections in the p250 Quick Start Guide located on our website. When mounting the laser, use only one metric or SAE fastener per mounting tab on the baseplate. Do not use any type of jackscrew arrangement as this will twist the baseplate and may distort the tube.

Contents Description

Customer Communication Flier 'Laser Web Guide' - Instead of the laser manual CD, please follow the instructions for our latest laser [manual\(s\)](#) located on our website.

Quick Start Plug p250 – connects to the User I/O connector. Jumpers are built into the plug to enable the laser's interlock circuits for initial start-up and testing.

Ethernet Crossover Cable– provides the communications link between a host computer and the p250 laser for accessing operating parameters via a TCP/IP web-based interface.

DC Power Cable Set (not shown) p250 – connects 48 VDC from the DC power supply to the p250 laser. Standard cable length is 2.0 meters (6.5 ft).

BNC Control Cable – coaxial cable delivers the PWM Command signal from your PWM controller to the laser's Quick Start Plug.

1/2" Tubing Fitting Kit – provides a means to replace the p250's 12 mm coolant fittings with fittings that accept 1/2" coolant tubing. See the Connecting section for important installation details.

Cooling Tubing p250 – carries cooling water from the chiller (not included) to the laser and back. This black polyethylene tubing is 12 mm O.D. by 30 feet and must be cut to length.

Introduction

Contents and Description (Continued):

p250 Mounting Bolts (not standard)– Fasten the p250 to your mounting surface. Three M8 x 1.25 (Metric) 5/16-18 mm (English).

Spherical Washer Sets – provides a filtering and connection point to the laser from your facility’s gas purge system.

Gas Purge Kit p250– provides a filtering and connection point to the laser from your facility’s gas purge system.

Spare Fuses (not shown) p250– 30A slow-blow fuses protect the p250’s internal circuitry.

Final Test Report (not shown) p250– contains data collected during the laser’s final pre-shipment test.

Table 1-1 p250 ship kit contents.

Shipping Box Contents	Qty	Shipping Box Contents	Qty
p250 Laser.....	1	Quick Start Plug	1
Laser Web Guide	1	Mounting Hardware Kit.....(*Not Standard)	
Ethernet Crossover Cable	1	Gas Purge Kit	1
BNC Control Cable	1	Spare Fuses (not shown).....	4
12 mm Cooling Tubing.....	1	Final Test Report (not shown)	1
DC Power Cables.....	1		

Maximum torque 12 Nm (106 in-lb). Minimum thread engagement should be 16 mm or 0.625 in.

*Recommend using low-outgassing thread lock adhesive or locking washer.

Caution Do not use more than one fastener per foot, otherwise damage to your
Possible laser will occur!
Equipment
Damage



Introduction

Contents Description (Continued)

SYNRAD[®] CO₂
Laser Web Guide

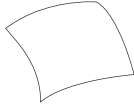

Quick Start Plug



Ethernet Crossover
Cable



1/2" Tubing Fittings



BNC Control Cable



Mounting Bolts/
Spherical Washers



12 mm Cooling Tubing

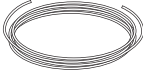

Gas Purge Kit



DC Power Cables

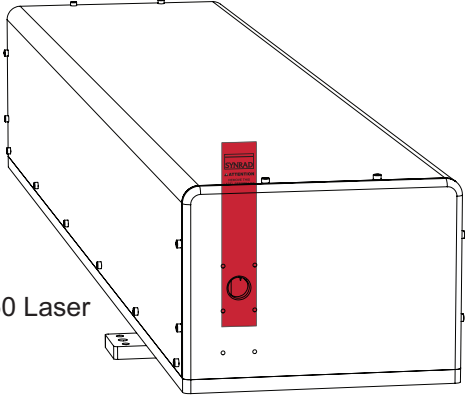

Pulstar p250 Laser

Figure 1-1 p250 ship kit contents.

Introduction

Nomenclature

The nomenclature section includes:

- Model numbers
- Laser versions

The first three characters designate the Model Series, second three characters indicate the power option, the next character signifies the safety option which is an "S" (Standard) for OEM models. The next character indicates the model revision or laser build and the last three characters indicate the beam options where 10.6 is 10.6um.

Refer to the following figure for further examples.

Laser versions

Pulstar™ lasers are divided into two distinct functional categories: Keyswitch and OEM models. In addition to a manual Keyswitch for resetting faults, all Keyswitch-equipped lasers incorporate a manual shutter switch to block the laser's output aperture as an added safety measure.

SYNRAD® OEM lasers are primarily designed as components for integration into larger processing systems by the Original Equipment Manufacturer (OEM) or System Integrator who bears the responsibility for meeting the appropriate laser safety requirements for Class 4 laser systems.

Pulstar p250 lasers are currently available only as OEM lasers; however, they do include an EM shutter assembly.

Introduction

Nomenclature (Continued)

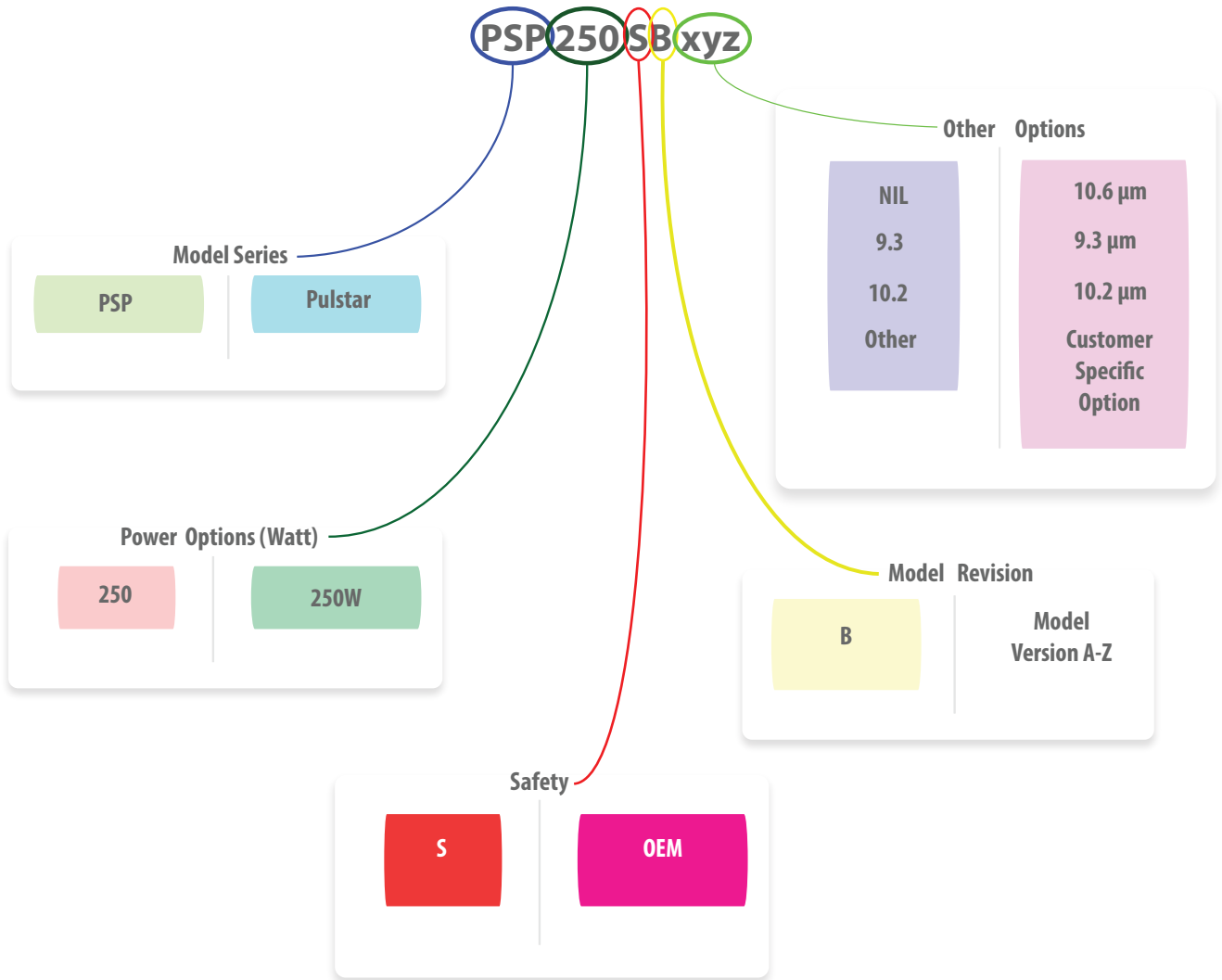

Figure 1-2 Anatomy of a model number.

Laser Safety

2

Laser Safety Introduction

- Hazard Information – includes equipment label terms and hazards, please familiarize yourself with all definitions and their significance.
- General & Other Hazards – provides important information about the hazards and unsafe practices that could result in death, severe injury, or product damage.
- Disposal – information on your p250 laser parts and/or components as they pertain to disposal.
- Additional Safety Information – describes how to find additional information about your p250 laser.
- Compliance – explains in the subsections therein applicable and appropriate regulation information.

Note: Read the entire safety section. This will ensure you are familiar with the hazards and warnings prior to starting.

Warning Serious personal injury



This Class 4 CO₂ laser product emits invisible infrared laser radiation in the 9.3–10.6 μm wavelength band.

Because direct or diffuse laser radiation can inflict severe corneal injuries, always wear eye protection when in the same area as an exposed laser beam.

Do not allow the laser beam to contact a person!

This product emits an invisible laser beam that is capable of seriously burning human tissue.

Always be aware of the beam's path and always use a beam block while testing.

Laser Safety

Hazard Information

Hazard information includes terms, symbols, and instructions used in this manual or on the equipment to alert both operating and service personnel to the recommended precautions in the care, use, and handling of Class 4 laser equipment.

Terms

Certain terms are used throughout this manual or on the equipment labels. Please familiarize yourself with their definitions and significance.









Parameter	Description
 	<p>WARNING: Potential & Imminent hazards which, if not avoided, could result in death or serious injury.</p> <p>Alerts operator of serious dangers, hazardous radiation, hazardous voltages, vapor hazard, & reflective dangers.</p>
	<p>DANGER: Hazards which, if not avoided, could result in minor or moderate injury.</p> <p>Alerts operator of lifting dangers.</p>
	<p>CAUTION: Potential hazards or unsafe practices which, if not avoided, may result in product damage.</p> <p>Alerts operator of equipment dangers.</p>
  	<p>IMPORTANT NOTES & TIPS:</p> <p>Content specific information and/or recommendations.</p>

Figure 2-1 Labeling terms and definitions.

Warning
Serious personal injury





For laser systems being used or sold within the U.S.A., customers should refer to and follow the laser safety precautions described American National Standards Institute (ANSI) document Z136.1-2014, Safe Use of Lasers.

For laser systems being used or sold outside the U.S.A., customers should refer to and follow the laser safety precautions described in European Normative and International Electrotechnical Commission documents IEC/TR 60825-14:2014, Safety of Laser Products – §14: A User's Guide.

Laser Safety

General hazards

Following are descriptions of general hazards and unsafe practices that could result in death, severe injury, or product damage. Specific warnings and cautions not appearing in this section are found throughout the manual.

Warning Serious personal injury



Do not allow laser radiation to enter the eye by viewing direct or reflected laser energy.

CO₂ laser radiation can be reflected from metallic objects even though the surface is darkened. Direct or diffuse laser radiation can inflict severe corneal injuries leading to permanent eye damage or blindness. All personnel must wear eye protection suitable for CO₂ radiation, e.g. 9.3–10.6 μm when in the same area as an exposed laser beam.

Eye wear protects against scattered energy but is not intended to protect against direct viewing of the beam—never look directly into the laser output aperture or view scattered laser reflections from metallic surfaces.

Enclose the beam path whenever possible. Exposure to direct or diffuse CO₂ laser radiation can seriously burn human or animal tissue, which may cause permanent damage.

This product is not intended for use in explosive, or potentially explosive, atmospheres!

Materials processing with a laser can generate air contaminants such as vapors, fumes, and/or particles that may be noxious, toxic, or even fatal. Safety Data Sheets (SDS) for materials being processed should be thoroughly evaluated and the adequacy of provisions for fume extraction, filtering, and venting should be carefully considered. Review the following references for further information on exposure criteria:

ANSI Z136.1-2014, Safe Use of Lasers, § 7.3.

U.S. Government's Code of Federal Regulations: 29 CFR §1910, §§ Z.

Threshold Limit Values (TLV's) published by the American Conference of Governmental Industrial Hygienists (ACGIH).

It may be necessary to consult with local governmental agencies regarding restrictions on the venting of processing vapors.

The use of aerosol dusters containing difluoroethane causes "blooming", a condition that significantly expands and scatters the laser beam. This beam expansion can effect mode quality and/or cause laser energy to extend beyond the confines of optical elements in the system, possibly damaging acrylic safety shielding. Do not use air dusters containing difluoroethane in any area adjacent to CO₂ laser systems because difluoroethane persists for long time periods over wide areas.

Laser Safety

P250 lasers should be installed and operated in manufacturing or laboratory facilities by trained personnel only. Due to the considerable risks and hazards associated with the installation and operational use of any equipment incorporating a laser, the operator must follow product warning labels and instructions to the user regarding laser safety. To prevent exposure to direct or scattered laser radiation, follow all safety precautions specified throughout this manual and exercise safe operating practices per ANSI Z136.1-2014, Safe Use of Lasers at all times when actively lasing.

Due to the specific properties of laser light, a unique set of safety hazards that differ from other light sources must be considered. Just like light, lasers can be reflected, refracted, diffracted or scattered.

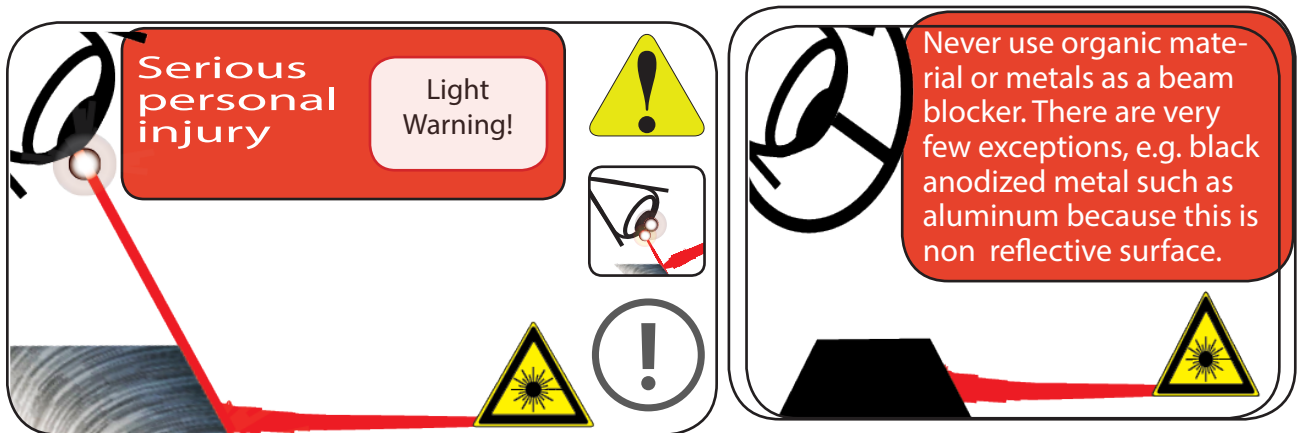

Figure 2-2 Always wear safety glasses or protective goggles with side shields to reduce the risk of damage to the eyes when operating the laser.

A CO₂ laser is an intense energy source and will ignite most materials under the proper conditions. Never operate the laser in the presence of flammable or explosive materials, gases, liquids, or vapors.

Warning
Serious
personal
injury

“Caution ⚠ - The use of controls or adjustments or performance of procedures other than those specified herein may result in hazardous radiation exposure.”



Safe operation of the laser requires the use of an external beam block to safely block the beam from traveling beyond the desired work area. Do not place your body or any combustible object in the path of the laser beam. Use a water-cooled beam dump or power meter, or similar non-scattering, noncombustible material as the beam block. Never use organic material or metals as the beam blocker; organic materials, in general, are apt to combust or melt and metals act as specular reflectors which may create a serious hazard outside the immediate work area.

Always wear safety glasses or protective goggles with side shields to reduce the risk of damage to the eyes when operating the laser.

Laser Safety

Disposal

This product contains components that are considered hazardous industrial waste. If a situation occurs where the laser is rendered non-functional and cannot be repaired, it may be returned to SYNRAD® who, for a fee, will ensure adequate disassembly, recycling and/or disposal of the product.

Other hazards

The following hazards are typical for this product family when incorporated for intended use: (A) risk of injury when lifting or moving the unit; (B) risk of exposure to hazardous laser energy through unauthorized removal of access panels, doors, or protective barriers; (C) risk of exposure to hazardous laser energy and injury due to failure of personnel to use proper eye protection and/or failure to adhere to applicable laser safety procedures; (D) risk of exposure to hazardous or lethal voltages through unauthorized removal of covers, doors, or access panels; (E) generation of hazardous air contaminants that may be noxious, toxic, or even fatal.

Additional laser safety information

The SYNRAD web site https://www.synrad.com/resources/general_information/lasersafetyresources contains an online laser safety handbook that provides information on (1) Laser Safety Standards for OEM's/System Integrators, (2) Laser Safety Standards for End Users, (3) References and Sources, and (4) Assistance with Requirements.

In addition, the Occupational Safety and Health Administration (OSHA) provides an online Technical Manual located at http://www.osha.gov/dts/osta/otm/otm_iii/otm_iii_6.html Section III, Chapter 6 and Appendix III are good resources for laser safety information.

Another excellent laser safety resource is the Laser Institute of America (LIA). Their comprehensive web site is located at <http://www.lia.org>.

Laser Safety

P250 label locations

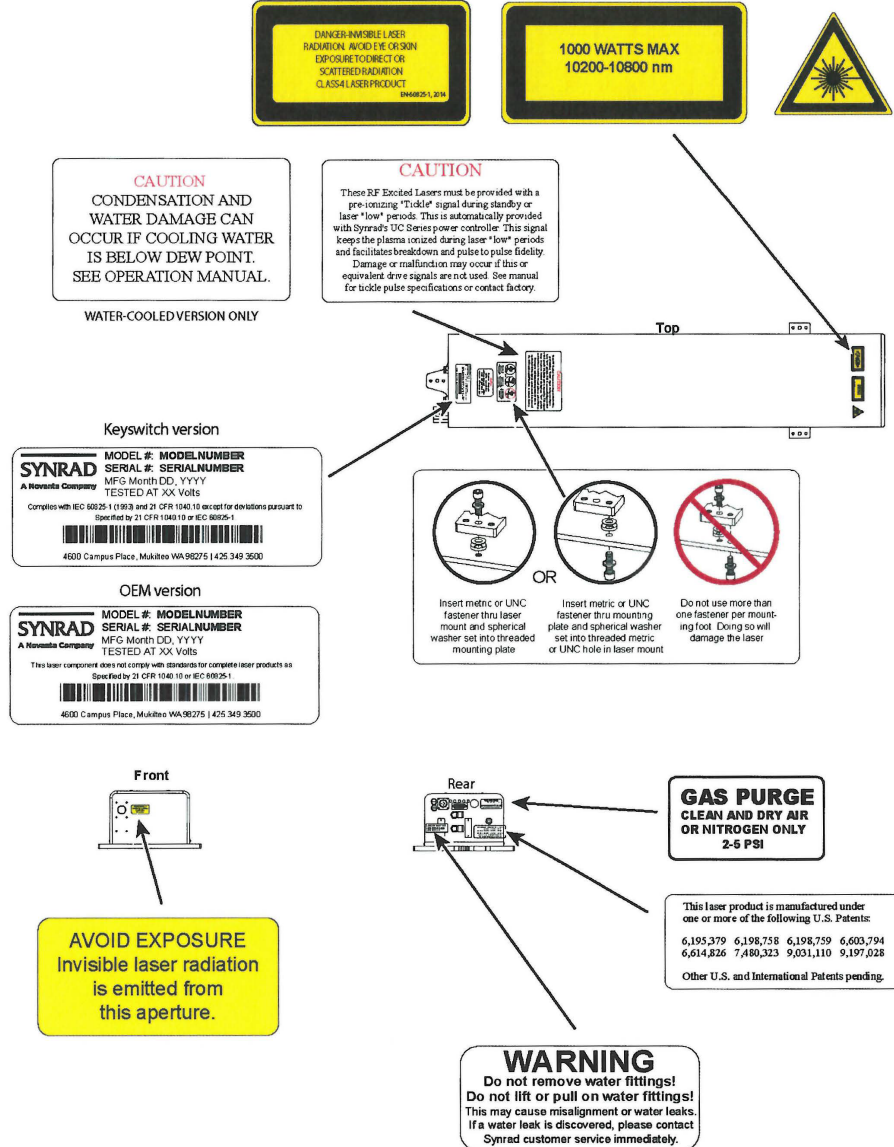

P250

Synrad	Description: DOCUMENT, COMPLIANCE, LABELING, LASER	Rev. A
File #: 900-21590-01	Page 12 of 20	

Figure 2-3 P250 hazard label locations.

Laser Safety

Agency compliance

- Center for Devices and Radiological Health (CDRH) requirements.
- Federal Communications Commission (FCC) requirements.
- European Union (EU) requirements.

SYNRAD® lasers are designed, tested, and certified to comply with certain United States (U.S.) and European Union (EU) regulations. These regulations impose product performance requirements related to electromagnetic compatibility (EMC) and product safety characteristics for industrial, scientific, and medical (ISM) equipment. The specific provisions to which systems containing p250 lasers must comply are identified and described in the following paragraphs. Note that compliance to CDRH, FCC, and EU requirements depends in part on the laser version selected—Keyswitch or OEM.

In the U.S., laser safety requirements are governed by the Center for Devices and Radiological Health (CDRH) under the auspices of the U.S. Food and Drug Administration (FDA) while radiated emission standards fall under the jurisdiction of the U.S. Federal Communications Commission (FCC). Outside the U.S., laser safety and emissions are governed by European Union (EU) Directives and Standards.

In the matter of CE-compliant laser products, SYNRAD assumes no responsibility for the compliance of the system into which the product is integrated, other than to supply and/or recommend laser components that are CE marked for compliance with applicable European Union Directives.

Because OEM laser products are intended for incorporation as components in a laser processing system, they do not meet all of the Standards for complete laser processing systems as specified by 21 CFR, §1040 or EN 60825-1. SYNRAD assumes no responsibility for the compliance of the system into which OEM laser products are integrated.

Center for Devices and Radiological Health (CDRH) requirements

Product features incorporated into the design of p250 lasers to comply with CDRH requirements are integrated as panel controls or indicators, internal circuit elements, or input/output signal interfaces. Specifically, these features include a laser and laser ready indicators, remote interlock for power on/off, a laser aperture shutter switch, and a five-second delay between power on and lasing. Incorporation of certain features is dependent on the laser version (Keyswitch or OEM). Table 1, Class 4 safety features, indicates which features are available on p250 lasers, the type and description of the feature, and if the feature is required by CDRH regulations.

OEM models

P250 OEM lasers are OEM products intended for incorporation as components in laser processing systems. As supplied by SYNRAD, these lasers do not meet the requirements of 21 CFR, §§J without additional safeguards. In the U.S., the Buyer of these OEM laser components is solely responsible for the assurance that the laser processing system sold to an end user

Laser Safety

components to ensure that they meet all applicable local laser safety requirements. In cases where the Buyer is also the end-user of the OEM laser product, the Buyer/end-user must integrate the laser so that it complies with all applicable laser safety standards as set forth above.

Federal Communications Commission (FCC) requirements

The United States Communication Act of 1934 vested the Federal Communications Commission (FCC) with the authority to regulate equipment that emits electromagnetic radiation in the radio frequency spectrum. The purpose of the Communication Act is to prevent harmful electromagnetic interference (EMI) from affecting authorized radio communication services. The FCC regulations that govern industrial, scientific, and medical (ISM) equipment are fully described in 47 CFR, §18, §5C.

SYNRAD® p250 lasers have been tested and found to comply by demonstrating performance characteristics that have met or exceeded the requirements of 47 CFR, §18, Radiated and Conducted Emissions.

FCC information to the user

Note: The following FCC information to the user is provided to comply with the requirements of 47 CFR, §18, §5213.

Interference Potential

In our testing, SYNRAD has not discovered any significant electrical interference traceable to p250 lasers.

System Maintenance

Ensure that all exterior covers are properly fastened in position.

Measures to Correct Interference

If you suspect that your laser interferes with other equipment, take the following steps to minimize this interference:

- 1 Use shielded cables to and from the equipment that is experiencing interference problems.
- 2 Ensure that the laser is properly grounded to the same electrical potential as the equipment or system it is connected to.

FCC caution to the user

The Federal Communications Commission warns the user that changes or modifications of the unit not expressly approved by the party responsible for compliance could void the user's authority to operate the equipment.

Laser Safety

European Union (EU) requirements

RoHS compliance

SYNRAD® p250 lasers meet the requirements of the European Parliament and Council Directive 2015/863/EU on the Restriction of the Use of Certain Hazardous Substances in Electrical and Electronic Equipment that establishes maximum concentration values for certain hazardous substances in electrical and electronic equipment.

Laser safety standards

Under the Low Voltage Directive, 2014/35/EC, the European Norm (EN) document EN 60825-1:2007 was developed to provide laser safety guidance and includes clauses on Engineering Specifications, Labeling, Other Informational Requirements, Additional Requirements for Specific Laser Products, Classification, and Determination of the Accessible Emission Level. To develop a risk assessment plan/laser safety program for users, see IEC/TR 60825-14:2004 that includes clauses on Administrative Policies, Laser Radiation Hazards, Determining the MPE, Associated Hazards, Evaluating Risk, Control Measures, Maintenance of Safe Operation, Incident Reporting and Accident Investigation, and Medical Surveillance.

OEM models

p250 OEM lasers are OEM products intended for incorporation as components in laser processing systems. As supplied by SYNRAD, these lasers do not meet the requirements of EN 60825-1 without additional safeguards. European Union Directives state that “OEM laser products which are sold to other manufacturers for use as components of any system for subsequent sale are not subject to this Standard, since the final product will itself be subject to the Standard.” This means that Buyers of OEM laser components are solely responsible for the assurance that the laser processing system sold to an end-user complies with all laser safety requirements before the actual sale of the system. Note that when an OEM laser component is incorporated into another device or system, the entire machinery installation may be required to conform to EN 60825-1; EN 60204-1:2006, Safety of Machinery; the Machinery Directive, EN 2006/42/EC; and/or any other applicable Standards and in cases where the system is being imported into the U.S., it must also comply with CDRH regulations.

In cases where the Buyer is also the end-user of the OEM laser product, the Buyer/end-user must integrate the laser so that it complies with all applicable laser safety standards as set forth above. Table 1, Class 4 safety features, summarizes p250 product features, indicating the type and description of features and whether those features are required by European Union regulations.

Electromagnetic interference standards

The European Union’s Electromagnetic Compatibility (EMC) Directive, 2014/30/EU, is the sole Directive developed to address electromagnetic interference (EMI) issues in electronic equipment. In particular, the Directive calls out European Norm (EN) documents that define the emission and immunity standards for specific product categories. For p250 lasers, EN 61000-6-4 defines radiated and conducted RF emission limits while EN 61000-6-2 defines immunity requirements for industrial environments.

Laser Safety

SYNRAD® p250 lasers have demonstrated performance characteristics that have met or exceeded the requirements of EMC Directive 2014/30/EU.

Table 2-1 Class 4 safety features.

Feature	Location / Description	Required by:		Available on:
		CDRH	EN60825-1	OEM P250
Keyswitch¹	Rear panel control On/Off/Reset Keyswitch controls power to laser electronics. Key cannot be removed from switch in the "On" position.	Yes	Yes	No
Shutter function	Laser control Functions as a beam attenuator to disable RF driver/laser output when closed.	Yes	Yes	Yes
Shutter indicator	Rear panel indicator (Blue) Illuminates blue to indicate shutter is open.	No	No	Yes
Ready indicator	Rear panel indicator (Yellow) Indicates that laser has power applied and is capable of lasing.	Yes	Yes	Yes
Lase indicator	Rear panel indicator (Red) Indicates that is actively lasing. Lase LED illuminates when the duty cycle of the Command signal is long enough to produce laser output.	No	No	Yes
Five second delay	circuit element Disables RF driver/laser output for five seconds after Keyswitch is turned to "On" or remote reset/start pulse is applied when Keyswitch is in "On" position.	Yes	No	Yes
Power fail lockout¹	circuit element Disables RF driver/laser output if input power is removed then later reapplied (AC power failure or remote interlock actuation) while Keyswitch is in "On" position.	Yes	Yes	No
Remote Interlock	Rear panel connection Disables RF driver/laser output when a remote interlock switch on an equipment door or panel is opened.	Yes	Yes	Yes
Remote Interlock	Rear panel indicator (Green/Red) Illuminates green when Remote Interlock circuitry is closed indicator Illuminates red when interlock circuitry is open.	No	No	Yes
Over temperature	circuit element Temperature shutdown occurs if temperature of the laser protection tube rises above safe operating limits.	No	No	Yes
Temp indicator	Rear panel indicator (Green/Red) Illuminates green when laser temperature is within operating limits, changing to red when thermal limits are exceeded.	No	No	Yes
Warning labels	p250 exterior Labels attached to various external housing locations to warn personnel of potential laser hazards.	Yes	Yes	Yes

1 Not available on p250 OEM lasers

Laser Safety

When integrating SYNRAD® p250 OEM lasers, the Buyer and/or integrator of the end system is responsible for meeting all applicable Standards to obtain the CE mark. To aid this compliance process, SYNRAD testing program has demonstrated that p250 lasers comply with the relevant requirements of Directive 2014/30/EU, the Electromagnetic Compatibility Directive, as summarized in Table 2 below.

Table 2-2 European Union Directives.

Applicable Standards / Norms

2004(2014)/108(30)/EU	Electromagnetic Compatibility Directive
2006/95/EC	Low Voltage Directive
2015/863/EU	RoHS Directive
EN 61010-1:2001	Safety Requirements for Electrical Equipment for Measurement, Control, and Laboratory Use - Part 1: General Requirements
EN 61000-6-4:2007	Radiated Emissions Group 1, Class A
EN 61000-6-4:2007	Conducted Emissions Group 1, Class A
EN 61000-6-2:2005	Electrostatic Discharge Immunity
EN 61000-6-2:2005	RF Electromagnetic Field Immunity
EN 61000-6-2:2005	Electrical Fast Transient/Burst Immunity
EN 61000-6-2:2005	Conducted RF Disturbances Immunity

After a laser or laser processing system has met the requirements of all applicable EU Directives, the product can bear the official compliance mark of the European Union as a Declaration of Conformity.

Laser Safety



Declaration of Conformity	
in accordance with ISO / IEC 17050-2:2004	
We,	
Manufacturer's Name:	SYNRAD® A ©Novanta Company
Manufacturer's Address:	4600 Campus Place Mukilteo, WA 98275 U.S.A.
Hereby declare under our sole responsibility that the following equipment:	
Product Name:	Pulstar™ OEM p250 Laser
Model Number:	PSP250SB (*OEM)
Conforms to the following Directive(s) and Standard(s):	
Applicable Directive(s):	2014/30/EU Electromagnetic Compatibility Directive 2014/35/EU Low Voltage Directive (EU) 2015/863 RoHS Directive
Applicable Standard(s):	EN 61010-1:2010 Safety Requirements for Electrical Equipment for Measurement, Control, and Laboratory Use - Part 1: General Requirements EN 61000-6-4:2007 Radiated Emissions, Group 1, Class A EN 61000-6-4:2007 Conducted Emissions, Group 1, Class A EN 61000-6-2:2005 Electrostatic Discharge Immunity EN 61000-6-2:2005 RF Electronic Fields Immunity EN 61000-6-2:2005 Electrical Fast Transient/burst Immunity EN 61000-6-2:2005 Conducted RF Disturbances Immunity
*OEM lasers do not comply with EN 60825-1:2014, <i>Safety of Laser Products</i> . Buyers of OEM laser products are solely responsible for meeting applicable Directives and Standards for CE compliance and marking.	
Corporate Officer:	European Contact:
 _____ Glenn Gardner, President & GM of SYNRAD	Novanta Distribution (USD) GmbH Parkring 57-59 85748 Garching bei München, Germany
Dated: 7/22/19 _____	 MADE IN THE U.S.A. 900-20976-04 Rev D

Figure 2-3 p250 Declaration Document.

Operation

3

Chapter Introduction

Use information in this chapter to familiarize yourself with Pulstar p250 controls and indicators and to begin operating the laser.

- Controls and indicators – displays and describes exterior controls and indicators on Pulstar p250 lasers.
- Initial start-up – Reference the appropriate [Quick Start Guide](#) on our website to learn how to start your p250 laser while verifying proper operation.

Warning **Serious** **personal** **injury**



This CO₂ laser emits *invisible infrared laser radiation* in the 9.3 – 10.6 μm wavelength band that can seriously damage human tissue.

Because direct or diffuse laser radiation can inflict severe corneal injuries, always wear eye protection when in the same area as an exposed laser beam.

Do not allow the laser beam to contact a person!

This product emits an invisible laser beam that is capable of seriously burning human tissue. Always be aware of the beam's path and always use a beam block while testing.

Caution **Possible** **Equipment** **Damage**



Remove the aperture seal before firing the laser!

The self-adhesive seal is installed to prevent dust from entering the laser housing during shipment and installation and must be removed before operation.

During laser operation, use a gas purge to keep dust and vapor out of the beam path.

When mounting optical components to OEM p250 lasers, the 8–32 UNC fasteners must extend no further than 8.8 mm (0.35") into the laser's faceplate otherwise possible damage may occur.

Operation

Controls and indicators

- OEM p250 front panel
- OEM p250 rear panel

OEM p250 front panel

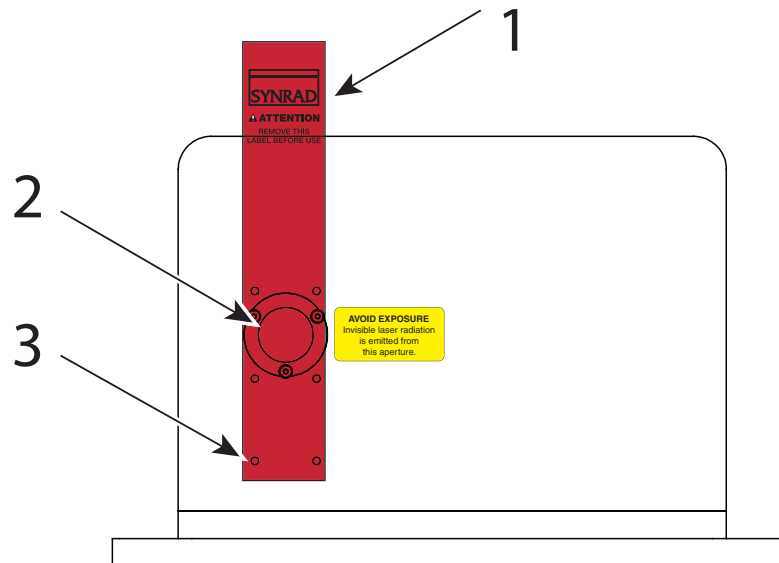

Figure 3-1 Pulstar OEM p250 front panel controls and indicators.

- 1 Aperture Seal** – prevents dust from damaging laser optics during shipping. Remove the red self-adhesive label before applying power to the laser.
- 2 Laser Aperture** – provides an opening in the p250's front panel from which the beam exits.
- 3 Optical Accessories Mounting** – provides four threaded holes (8–32 UNC) for mounting optional beam delivery components. Because excessive weight may damage the laser, consult SYNRAD before mounting components not specifically designed as Pulstar options. Refer to the OEM p250 package outline drawings in the Technical Reference chapter for mounting dimensions.

Operation

OEM p250 rear panel

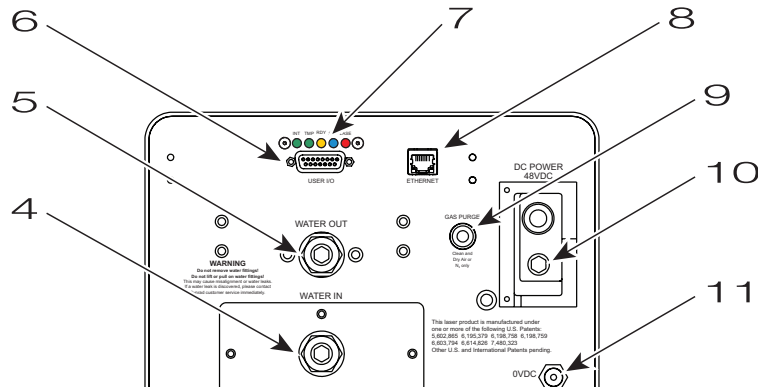

Figure 3-2 Pulstar OEM p250 rear panel controls and indicators.

- 4 WATER IN Port** – provides a 12 mm inlet connection to the p250 laser’s cooling system for 12 mm O.D. cooling tubing.
- 5 WATER OUT Port** – provides a 12 mm outlet connection from the p250 laser’s cooling system for 12 mm O.D. cooling tubing.
- 6 User I/O Port** – provides a connection point for auxiliary output power, as well as input and output signals. Refer to the Technical Reference chapter for interface details and signal descriptions.
- 7 Status Indicators** – LED indicators display p250 operating status. From left to right:
 - INT** (Remote Interlock) LED – illuminates green to indicate the remote interlock circuit is closed and lasing may be enabled; the LED is red and lasing is disabled if the interlock input is open.
 - TMP** (Temperature) LED – illuminates green to indicate laser temperature is within limits and lasing may be enabled; the LED is red and lasing is disabled if laser temperature rises above safe operating limits.
 - RDY** (Ready) LED – illuminates yellow when the laser is enabled to indicate that lasing will begin when a PWM Command signal is applied, provided the SHT LED is illuminated.
 - SHT** (Shutter) LED – illuminates blue to indicate that a Shutter Open Request signal is connected to the User I/O port and lasing may be enabled.
- 8 Ethernet Port**- provides the connection point for a TCP/IP web-based interface between your computer or network and the laser.
- 9 Gas Purge Port** – provides a low pressure nitrogen (or pure air) connection to prevent dust and debris from damaging electronic or optical components inside the laser housing.
- 10 +48 VDC Input Terminal** – M6 threaded stud receives 48 VDC from the DC power supply.
- 11 GND (-) Terminal** – M6 threaded stud provides connection point for negative (ground) side of the 48 VDC power supply.

Operation

Start-up and pulsed operation

Warning **Serious** **personal** **injury**



Remote interlock faults are not latched on Pulstar OEM p250 lasers. Clearing the fault condition re-enables the RDY indicator and the laser will fire immediately provided the SHT indicator is lit and a PWM Command signal is applied. Because exposure to 10.2-10.6 μm CO₂ laser radiation can inflict severe corneal injuries and seriously burn human tissue, the OEM or System Integrator must ensure that appropriate safeguards are in place to prevent unintended lasing.

Caution **Possible** **Equipment** **Damage**



Operating the laser at **coolant temperatures above 22 °C (72 °F)** may result in decreased performance and/or premature failure of electronic components.

Contamination on the laser's output window (or on any beam delivery optic) can absorb enough energy to damage optical components in the beam path.

Periodically inspect the p250's output window and all other beam delivery optics for signs of contaminants and then carefully clean as required.

In dirty environments, purge laser optics using filtered air or nitrogen to prevent vapor and debris from accumulating on optical surfaces.

Initial Start-up

See your laser's Quick Start Guide located on our website. Also reference the Laser Start Sequence figure in the Maintenance and Troubleshooting section within this manual.

4

Chapter Introduction

This chapter contains technical information for your Pulstar p250 laser.

- Technical overview – briefly describes Pulstar’s technology and basic optical setup.
- Controlling laser power – explains various aspects of Pulstar control signals.
- User I/O connections – describes input/output signals and specifications for the 15-pin User I/O connector.
- DC power cables – provides information about p250 DC power and voltage sense cables.
- Pulstar p250 web interface – explains details about the Pulstar p250’s Ethernet interface.
- Pulstar p250 firmware upgrade – describes how to perform an upgrade to the p250’s operating firmware.
- Integrating Pulstar safety features – describes how to integrate Pulstar p250 safety features into your automated control system.
- Pulstar p250 general specifications – provides specifications for the Pulstar p250 laser.
- Pulstar p250 outline and mounting drawings – illustrates laser package outline and mounting dimensions for p250 lasers.
- Pulstar p250 packaging instructions – illustrates how to package Pulstar p250 lasers for shipment.

Warning **Serious** **personal** **injury**



The long 9-11 μm wavelength of CO_2 lasers are easily reflected or scattered off metallic surfaces which can lead to personnel injury and/or damage to equipment.

Enclose the processing area in an interlocked enclosure and ensure proper safety glasses are worn.

Technical Reference

Technical overview

- Laser design
- RF power supply
- Optical setup

Laser design

Optical resonator

Pulstar® p250 lasers were developed using new technology developed by SYNRAD. This new technology, based on a hybrid waveguide/unstable resonator design, as shown in the figure below, enables SYNRAD to economically produce a symmetrical laser beam from a small but powerful laser capable of operating for many years with virtually no maintenance. Pulstar's unique extruded aluminum envelope offers excellent heat transfer, long gas life, and low operating costs in contrast to other laser tube technologies. Besides being the vessel that maintains the lasing environment, the aluminum tube is also the structural platform that integrates the laser's optical, electrical, and cooling components.

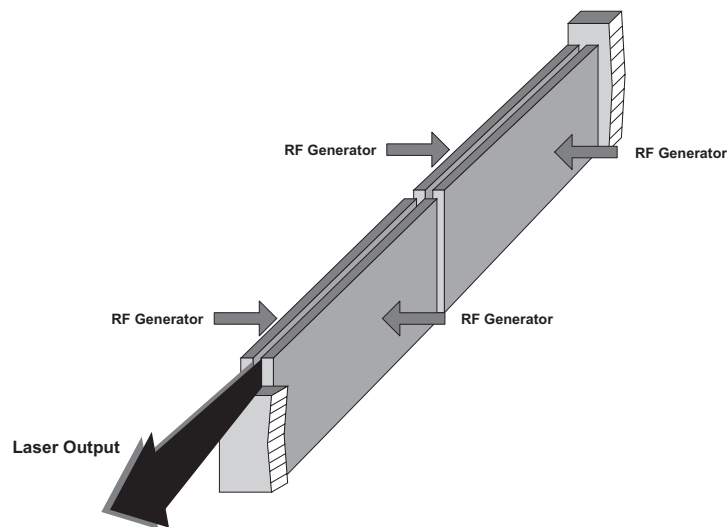

Figure 4-1 Hybrid waveguide/unstable resonator design.

The optical resonator, in conjunction with the electrodes and the gas mixture, generates the laser beam. Pulstar p250 optical resonators are comprised of three optical elements: a front mirror, a rear mirror, and an output window. These optical elements are fastened to the tube's exterior and are exposed to its interior through holes in the end caps. O-rings are sandwiched between optical elements and the end cap to form a gas seal and to provide a flexible cushion that allows the slight movement necessary for alignment. All optical elements are aligned and locked into place by factory technicians before the laser is shipped.

Technical Reference

The structure of the resonator and internal beam conditioning optics combine to produce a near Gaussian mode quality (M^2 factor) of <1.2 . (p250 only) Beam waist diameter is typically 6.7 mm at the output aperture and full-angle divergence due to diffraction is approximately 2.5 milliradians (a 2.5 mrad divergence means that beam diameter increases 2.5 mm over every one-meter distance traveled-p250 only). Beam ellipticity measures approximately <1.2 as it exits the resonator, but becomes closer to 1.0 in the far field (or at the point of focus) as shown in the figure below.

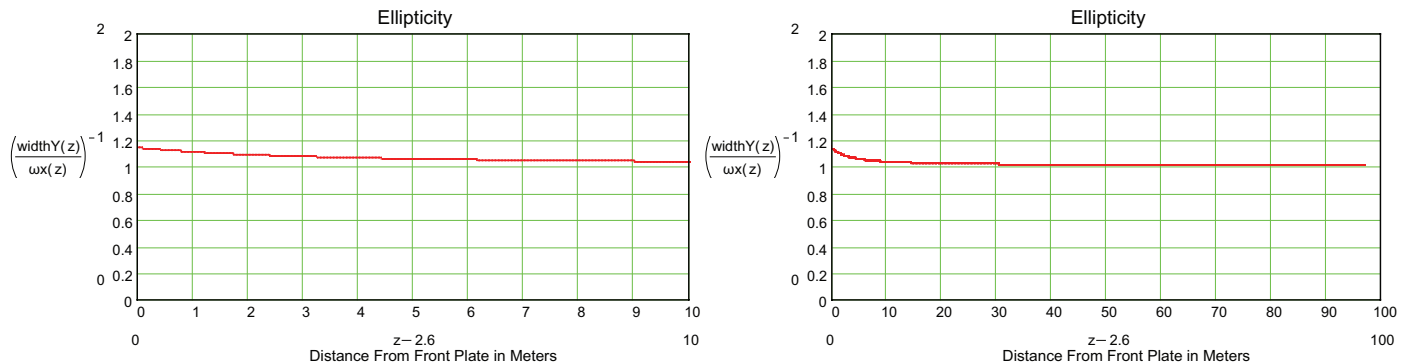

Figure 4-2 Pulstar p250 beam ellipticity.

Heat removal

Heat generated by excited CO_2 molecules is transferred to the bore walls by diffusion. Collected heat is transferred to the water in the cooling tubes by conduction of the electrodes and aluminum envelope. The coolant path is directed through corrosion-resistant copper alloy tubing to regulate laser temperature for maximum stability.

Beam conditioning

The p250 laser incorporates a novel beam conditioning system that first converts the beam to a circular profile, cleans up the beam to remove side lobes and improve beam quality. To do this, the laser beam exits the resonator and is turned back on itself through a front folding block that directs the beam into a cylindrical lens located about 0.63 m (25 in) away from the resonator output. The cylindrical lens converts the beam into a round beam which is then focused by a spherical focusing mirror through a water-cooled aperture (to remove any side lobes) and then onto another spherical mirror that collimates the beam. This beam then passes the shutter mechanism and through the rear folding mirror.

Polarization

Polarization is important in achieving the best cut quality from a laser and this is usually achieved with linear polarization aligned with the cut direction; however, in most applications where two axes of cut are required, linearly polarized light can lead to differences in cut quality depending on the orientation of the polarization with respect to the cutting direction.

Technical Reference

Converting the laser polarization from linear to circularly polarized light gives uniform cut quality in both axes. Circularly polarized light can be generated without significant power loss by using a circular polarizer (also known as a cut quality enhancer or CQE) or a simple phase retarding mirror. For the simplest and most cost-effective solution, a reflective phase retarder, laser polarization must be rotated by 45°.

The p250 is horizontally polarized at the faceplate. Rotating the polarization is usually done by mounting the laser at 45° to the horizontal or by using two or more mirrors. A CQE typically incorporates the turning mirrors and phase retarder into one housing.

Beam conditioning

The p250 laser incorporates a novel beam conditioning system that first converts the beam to a circular profile, cleans up the beam to remove side lobes and improve beam quality. To do this, the laser beam exits the resonator and is turned back on itself through a front folding block that directs the beam into a cylindrical lens. The lens converts the beam into a round beam which is then focused by a spherical focusing mirror through a water-cooled aperture (to remove any side lobes) and then onto another spherical mirror that collimates the beam.

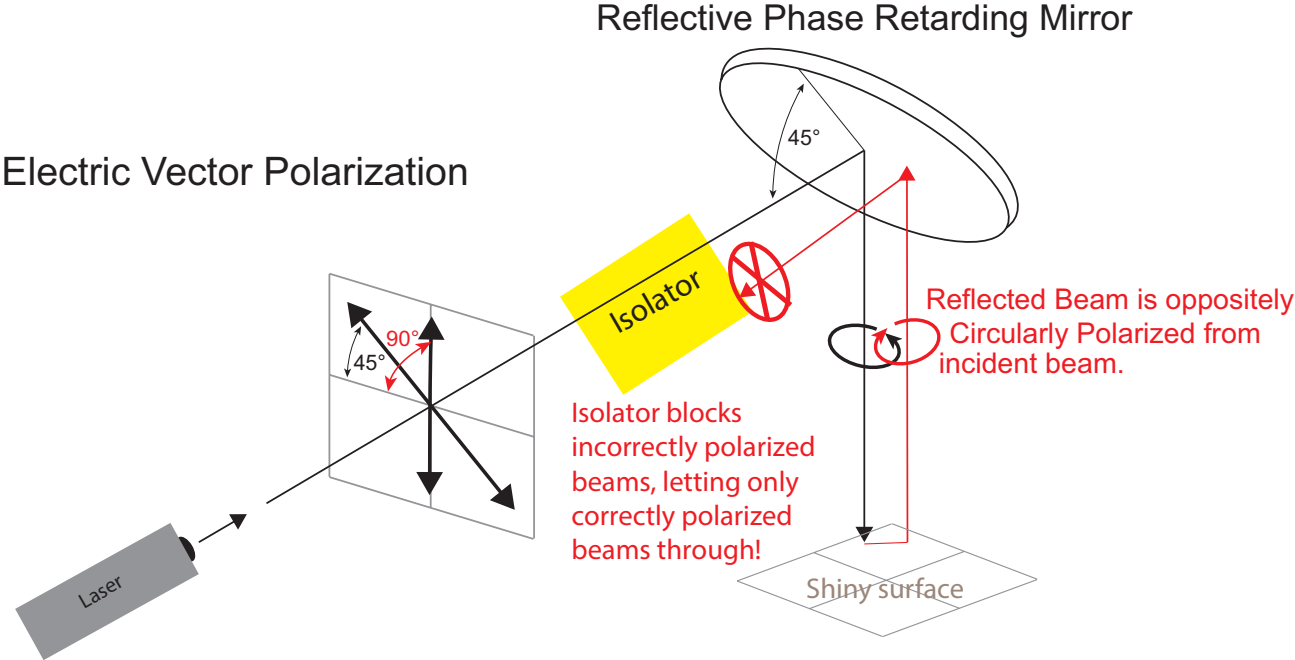

Figure 4-3 Converting 45° linear polarization to circular polarization.*

*(Original Pulstar p250 Operation Manual Version 1 illustration courtesy of II-VI inc.). p250 Output Beam is Linearly Polarized parallel in respect to the Baseplate. The polarization must be rotated by 45° before hitting the phase retarder.

Technical Reference

Caution
Possible
Equipment
Damage



Use an **optical isolator** to protect the laser from damage. Failure to do this, may **void the warranty** as equipment damage can occur.

Optical isolator

An optical isolator is an optical component that allows only the desired linearly polarized light through, preventing unwanted feedback back into the laser. P250 lasers do not have internal isolation. If isolation is required, an external third party unit is needed. An optical isolator only works with linearly polarized light and in conjunction with a (quarter wave) phase retarder. Beam delivery manufacturers may package the phase retarder and isolator inside one component commonly marketed as a “Beam Quality Enhancer.” Always double check the system with your supplier to ensure the isolator is present.

When laser processing reflective metals like iron, steel or aluminum, problems can occur if CO₂ laser energy is reflected by the workpiece back through the beam-delivery path and into the laser cavity. Back reflection can result in unwanted fluctuations of laser power, or even damage the cavity optics inside the laser. When a reflective material is processed, the use of a back reflection isolator is required.

An optical isolator only works with linearly polarized light and in conjunction with a (quarter wave) phase retarder. The isolator has to be oriented in a very specific rotational orientation relative to the linear polarization. Failure to do so will eliminate the protection of the isolator and incorrectly polarized outgoing lasing energy will not be blocked. Beam delivery manufacturers may package both the phase retarder and the isolator inside one component commonly marketed as a “Beam Quality Enhancer” or BQE. For example, the Haas Laser Technology Part Number [BQE-25-10.6-SYN](#) incorporates both polarization and isolation into one housing that can easily be mounted onto the face plate of the laser. Always double check the system with your supplier to ensure the isolator is present.

Beam delivery optics and setup

After selecting a laser for a CO₂ laser processing system, the two most important elements to consider are: (1) beam delivery optics to transmit the beam to the work area; and (2) focusing optics to focus the beam onto the part or material to be processed. Each element is crucial in the development of a reliable laser-based material processing system and each element should be approached with the same careful attention to detail.

Divergence, or expansion, of the laser beam is important in materials processing since a larger beam entering the focusing optic produces a smaller focused spot.

Technical Reference

Note: Optical components in the beam path must always be aligned to the actual beam path, not the laser faceplate. Because of slight variations in laser construction, the beam path may not always be centered in, or perpendicular to, the aperture in the faceplate.

Expander/collimators are optical devices that reduce beam divergence while at the same time increasing beam diameter by a selectable magnification factor. Adding an expander/collimator substantially reduces beam divergence and any variance in beam diameter caused by the changing optical path length in an XY (“flying optics”) table application. In fixed-length delivery systems where the laser is positioned only one meter away from the focusing optic and a small spot size is required, an expander/collimator is again the best solution to provide the required beam expansion before reaching the focusing optic.

Focusing optics

When selecting a focusing optic, the primary consideration should be material thickness and any vertical tolerances that occur during final part positioning rather than making a selection based only on minimum spot size. The chosen focal length should create the smallest possible focused spot while providing the depth of field required for the material to be processed.

Optics are fragile and must be handled carefully, preferably by the mounting ring only. Be careful to select optics that are thick enough to withstand the maximum assist gas pressure available for the process. This is especially important in metal cutting applications using high-pressure assist gases.

Cleanliness is another important issue affecting performance; a dirty or scratched lens will under perform and exhibit a vastly shortened lifetime. When the laser application requires air as an assist gas, use only breathing quality air available in cylinders from a welding supply company. Compressed shop air contains minute particles of oil and other contaminants that will damage optical surfaces. If compressed shop air is the only choice available, it must be filtered to the specifications shown in the following table.

Technical Reference

Table 4-1 Assist gas purity specifications.

Assist Gas	Typical Purpose	Specification
Air	Cutting/Drilling	Breathing Grade $\geq 99.9996\%$ purity; filtered to ISO Class 1 particulate level
Air	Cutting/Drilling	Compressed Instrument-grade air filtered and dried to ISO 8573-1:2010 Class 1, 2, 1 (≤ 10 1.0–5.0 μm particles/ m^3 ; ≤ -40 °F (-40 °C) dew point; ≤ 0.01 mg/ m^3 oil vapor)
Argon	Welding	High Purity Grade $\geq 99.998\%$ purity; filtered to ISO Class 1 particulate level
Helium	Welding	High Purity Grade $\geq 99.997\%$ purity; filtered to ISO Class 1 particulate level
Nitrogen	Cutting/Drilling	High Purity Grade $\geq 99.9500\%$ purity; filtered to ISO Class 1 particulate level
Oxygen	Cutting/Drilling	Ultra Pure Grade $\geq 99.9998\%$ purity; filtered to ISO Class 1 particulate level

Table 4-2 Purge gas specifications.

Purge Gas	Specification
Nitrogen	High Purity Grade $\geq 99.9500\%$ purity; filtered to ISO Class 1 particulate level
Air	Breathing Grade $\geq 99.9996\%$ purity; filtered to ISO Class 1 particulate level
Air	Compressed Instrument-grade air filtered and dried to ISO 8573-1:2010 Class 1, 2, 1 (≤ 10 1.0–5.0 μm particles/ m^3 ; ≤ -40 °F dew point; ≤ 0.01 mg/ m^3 oil vapor)
Gas Purge Pressure	Gas purge pressure range 0.14–0.34 bar (2–5 PSI) or a flow rate of 849–1699 liters/hour (30–60 SCFH). Do not exceed a pressure of 0.34 bar (5 PSI). Use only nitrogen or CDA (clean dry air) as a purge gas.

RF power supply

Pulstar p250 lasers are driven by two compact RF modules mounted internally in the laser chassis. Each RF module converts 48 VDC input power into a radio frequency (RF) signal that is then amplified and routed to its corresponding electrode structure in the laser tube where it excites the gas mixture in the tube to produce lasing.

Control circuitry built into the laser interrupts operation if any critical parameter is violated. Switches and sensors on the control board monitor various conditions and parameters that, if exceeded, pose a risk of potential damage to the laser. Additionally, laser operation is interrupted in response to the following conditions: (1) the EM shutter is closed; (2) the Shutter Open Request input signal is missing; (3) an over temperature or low coolant flow condition occurs; (4) the Remote Reset/Start Request input signal is enabled; (5) the Remote Interlock input signal is missing; or (6) any fault is present.

Technical Reference

Cooling & Setting coolant temperature

Choosing the correct coolant temperature is important to the proper operation and longevity of your laser. When coolant temperature is lower than the dew point (the temperature at which moisture condenses out of the surrounding air), condensation forms inside the laser housing leading to failure of laser electronics as well as damage to optical surfaces.

The greatest risk of condensation damage occurs when water-cooled lasers are run in a high heat/high humidity environment and the chiller's coolant temperature is colder than the dew point temperature of the surrounding air or when the system is shut down, but coolant continues to flow through the laser for extended periods of time.

Cooling guidelines

SYNRAD® recommends that the laser's cooling fluid contain at least 90% water (distilled or tap) by volume. In closed loop systems, use a corrosion inhibitor such as Optishield® Plus or equivalent. Avoid glycol-based additives as they reduce the coolant's capacity and high concentrations may affect power stability. For SYNRAD lasers, the minimum coolant set-point is 19 °C (66) °F so glycol is not necessary unless the chiller is subjected to freezing temperatures.

- In applications where biocides containing chlorides are used, concentrations should not exceed 25 parts per million (PPM).
- Maintain a coolant pH level above 7.0. We recommend the installation of a filter on the chiller's return line, especially in areas where water hardness is a problem.

The chiller's temperature setpoint must always be set above the dew point temperature. In cases where this is not possible within the specified coolant temperature range of 18 °C to 22 °C (64 °F to 72 °F), then the following steps MUST be taken to reduce the risk of condensation damage.

- Stop coolant flow when the laser is shut down.
- Increase coolant flow by an additional 3.8 LPM (1.0 GPM). Do not exceed a coolant pressure of 414 kPa (60 PSI).

To use the following dew point table, look down the Air Temp column and locate an air temperature in Fahrenheit or Celsius (°C values are shown in parentheses) that corresponds to the air temperature in the area where your laser is operating. Follow this row across until you reach a column matching the relative humidity in your location. The value at the intersection of the Air Temp and Relative Humidity columns is the Dew Point temperature in °F (or °C). The chiller's temperature setpoint must be set above the dew point temperature.

For example, if the air temperature is 85 °F (29 °C) and the relative humidity is 60%, then the dew point temperature is 70 °F (21 °C). Adjust the chiller's temperature setpoint to 72 °F (22 °C) to prevent condensation from forming inside the laser.

Technical Reference

Cooling guidelines

Refer to the following dew point temperature table for a range of air temperature and relative humidity values. Remember that the laser’s coolant temperature must be set above the dew point temperatures shown in the chart, but should not exceed the environmental specifications located in the General Specifications within this chapter of this manual.

- Air-condition the room or the enclosure containing the laser.
- Install a dehumidifier to reduce the humidity of the enclosure containing the laser.

Table 4.3 Dew point temperatures.

Dew Point Table °F

Air Temp (°F)	Relative Humidity (%)															
	20%	25%	30%	35%	40%	45%	50%	55%	60%	65%	70%	75%	80%	85%	90%	95%
60 °F	-	-	-	32	36	39	41	44	46	48	50	52	54	55	57	59
65 °F	-	-	33	37	40	43	46	48	51	53	55	57	59	60	62	64
70 °F	-	33	37	41	45	48	51	53	56	58	60	62	64	65	67	69
75 °F	-	37	42	46	49	52	55	58	60	62	65	67	68	70	72	73
80 °F	35	41	46	50	54	57	60	62	65	67	69	71	73	75	77	78
85 °F	40	45	50	54	58	61	64	67	70	72	74	76	78	80	82	83
90 °F	44	50	54	59	62	66	69	72	74	77	79	81	83	85	87	88
95 °F	48	54	59	63	67	70	73	76	79	81	84	86	88	90	92	93
100 °F	52	58	63	68	71	75	78	81	84	86	88	91	93	95	97	98

Technical Reference

Table 4.3 Dew point temperatures (Continued).

Dew Point Table °C

Air Temp (°C)	Relative Humidity (%)															
	20%	25%	30%	35%	40%	45%	50%	55%	60%	65%	70%	75%	80%	85%	90%	95%
16 °C	-	-	-	0	2	4	5	7	8	9	10	11	12	13	14	15
18 °C	-	-	1	3	4	6	8	9	11	12	13	14	15	16	17	18
21 °C	-	1	3	5	7	9	11	12	13	14	16	17	18	18	19	21
24 °C	-	3	6	8	9	11	13	14	16	17	18	19	20	21	22	23
27 °C	2	5	8	10	12	14	16	17	18	19	21	22	23	24	25	26
29 °C	4	7	10	12	14	16	18	19	21	22	23	24	26	27	28	28
32 °C	7	10	12	15	17	19	21	22	23	25	26	27	28	29	31	31
35 °C	9	12	15	17	19	21	23	24	26	27	29	30	31	32	33	34
38 °C	11	14	17	20	22	24	26	27	29	30	31	33	34	35	36	37

Technical Reference

Controlling laser power

- Control signals
- Operating modes

Note: Because all Pulstar OEM p250 lasers incorporate a built-in tickle generator (2-6 μ s pulses at 5kHz), there is no need to supply external tickle pulses. The application of external tickle pulses may affect the p250's pulsing performance.

Control signals

Much of the information provided in this section describes the application of PWM command signals to the p250 laser. If using an alternate method of laser control, thoroughly review this section, controlling laser power, as well as the following section, User I/O connections, for an understanding of the signal requirements necessary to control Pulstar lasers.

Tickle pulse

Tickle pulses pre-ionize the laser gas to just below the lasing threshold so that a further increase in pulse width adds enough energy to the plasma to cause laser emission. Tickle pulses cause the laser to respond predictably and almost instantaneously to PWM Command signals, even when there is considerable delay (laser off time) between applied Command signals. All Pulstar p250 lasers incorporate a built-in tickle generator, freeing customers from the need to supply external tickle pulses between lasing commands.

Warning
Serious
personal
injury



Because of phase differences, external tickle pulses may combine with the internally-generated tickle signal causing the LASE LED to flicker during the transition from tickle to lasing.

Laser output may occur if the LASE LED flickers.

Internal circuitry monitors the incoming PWM signal and determines the amount of time the laser was on (lasing) during the last 200 microsecond (μ s) interval. If the lasers 'on time' was greater than the preset tickle value, then no tickle pulse is generated because the PWM signal was sufficient to maintain a plasma state. If no PWM signal was applied during the 200- μ s measurement period (or was shorter than the preset tickle value), internal circuitry generates a tickle pulse such that the laser always receives a pre-set amount of RF drive averaged over any 200- μ s interval.

Technical Reference

Operation modes

Pulse Width Modulation (PWM)

Pulse Width Modulation, or PWM, controls laser power by varying the duty cycle of Pulstar's RF amplifiers, which in turn control the time-averaged RF power applied to the laser. The percentage of optical output increases as duty cycle increases (at a constant PWM frequency) or as PWM frequency decreases (at a constant duty cycle).

Pulstar p250 lasers are designed to operate at Command signal base frequencies up to 100 kHz; however, the choice of PWM frequency depends on the user's specific application. When considering Command frequencies at 5 kHz or below, please review Marking/engraving operation later in this section. For high-speed motion applications that cannot tolerate any ripple in the optical beam response but still require adjustable power levels, we recommend the use of higher PWM frequencies, up to 100 kHz maximum.

Command signal

The modulated Command signal applied between Pin 9, PWM Input, and Pin 1, PWM Return, of the User I/O connector on the Pulstar p250 laser has three parameters: signal amplitude, base frequency, and PWM duty cycle. By changing these parameters, you can command the beam to perform a variety of marking, cutting, welding, or drilling operations.

Warning **Serious** **personal** **injury**



Always use shielded cable when connecting to your PWM Command signal source to PWM Input/PWM Return inputs.

In electrically-noisy environments, long lengths of unshielded wire act like an antenna and may generate enough voltage to trigger un-commanded lasing.

The first Command signal parameter, signal amplitude, is either logic low—corresponding to laser beam off, or logic high—corresponding to beam on. The laser off voltage, typically 0 V, can range from 0.0 V to +0.8 VDC while the laser on voltage, typically 5 V, can range from +3.5 V to +6.7 VDC. Please refer to the following figures.

Pulse frequency, the second parameter, is the repetition rate of the PWM input signal. The p250's pulse frequency can range from a single-shot up to a maximum frequency of 100 kHz. The following figures illustrate representative output energy profiles of the p250 laser at various PWM duty cycles and pulse repetition frequencies (PRF).

The third Command signal parameter, PWM duty cycle, is the percentage of the period that the Command signal is high. For example, if the Command signal's amplitude (at 5 kHz) is high for 100 μ s and low for 100 μ s, it has a 50% duty cycle; if the amplitude is high for 190 μ s and low for 10 μ s, it has a 95% duty cycle. The following figure illustrates typical PWM Command signal parameters.

Technical Reference

As shown in the following figures, at low frequencies (approximately 1 kHz or less) and low duty cycles (approximately 20%), the p250 delivers maximum peak output power and energy while providing full depth of modulation (where the output rises from zero power to peak power on each pulse).

As illustrated in the following figure, the p250 laser delivering full peak power (approximately 800 W) and peak pulse energy (at the maximum 1000 μ s pulse width) with 100% depth of modulation. The leading edge of the output energy pulse reaches full peak power and then drops off slightly as the tube gain diminishes due to plasma heating.

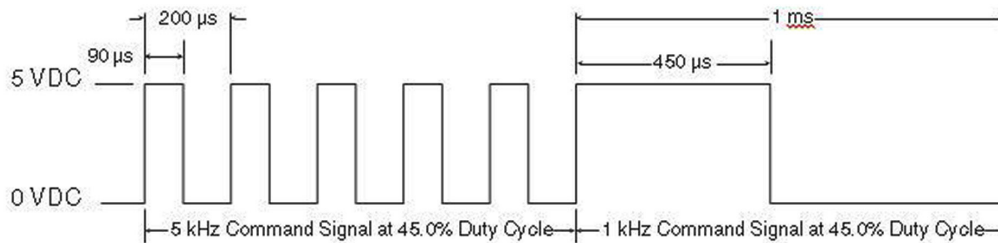

Figure 4-4 PWM command signal wave form.

Caution

Possible
Equipment
Damage



Hazardous DC voltages exist on DC power supply output terminals when the power supply is energized.

Contacting energized terminals may result in serious personal injury or death. Protect all 48 VDC connections from incidental contact in accordance with local, state, and national code requirements for electrical insulation and labeling.

All AC input wiring and fusing to the DC power supply must be sized and connected in accordance with applicable local, state, and National Electrical Code (NEC) requirements.

Local, state, and national code requirements supersede any recommendations provided in this manual. Do not plug and unplug the DC Power cable on the rear of the laser to switch DC power to the laser. Switching power under load causes arcing that will damage the connector and laser control board. To properly cycle power to the laser, switch the AC power source controlling the PS-48/4000 DC power supply.

Do not plug and unplug the DC Power cable on the rear of the laser to switch DC power to the laser. Switching power under load causes arcing that will damage the connector and laser control board. To properly cycle power to the laser, switch the AC power source controlling the PS-48/4000 DC power supply.

Do not reverse polarity when connecting the DC Power cable to your DC power source. Reversed DC polarity may damage the laser's internal RF power supply.

Carefully follow directions in the Operator's Manual to ensure that DC Power cable leads are properly connected to the correct DC output terminals.

Note: If you are not using a DC supply recommended by SYNRAD, we highly recommend installing a DC power supply with remote sense capability that can compensate for a minimum load lead loss (round-trip) of 1.0 V.

Technical Reference

Laser power is nominally linearly proportional to the PWM duty cycle. As PWM frequency increases, it will take a larger duty cycle before the laser starts to fire. However, at high PWM frequencies there is a significant threshold effect as shown in the figure below.

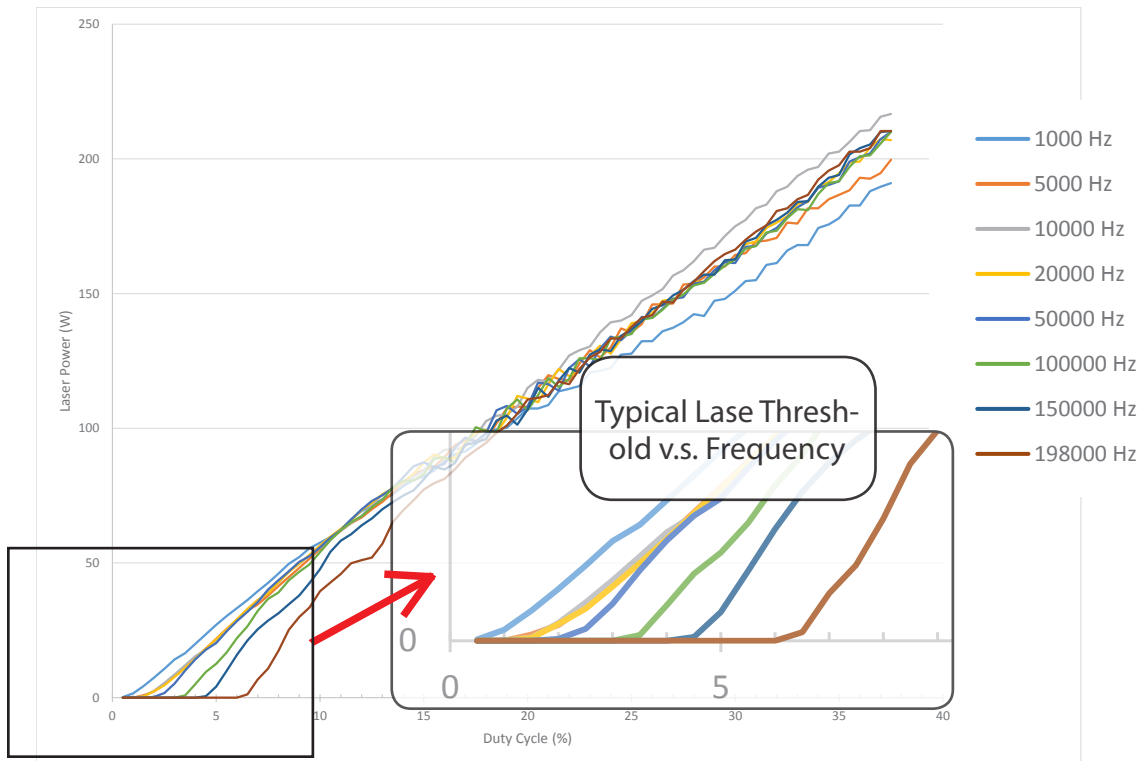

Figure 4-5 Typical power curve.

Important Note:



Because the p250 is a pulsed laser, it will not operate when a constant 5V (100% duty cycle) PWM signal is applied. If this occurs, lasing will halt and status LEDs/outputs will indicate a fault condition (see Troubleshooting in the Maintenance/Troubleshooting chapter for further information). The laser will begin lasing immediately when the PWM duty cycle drops below 100%.

Technical Reference

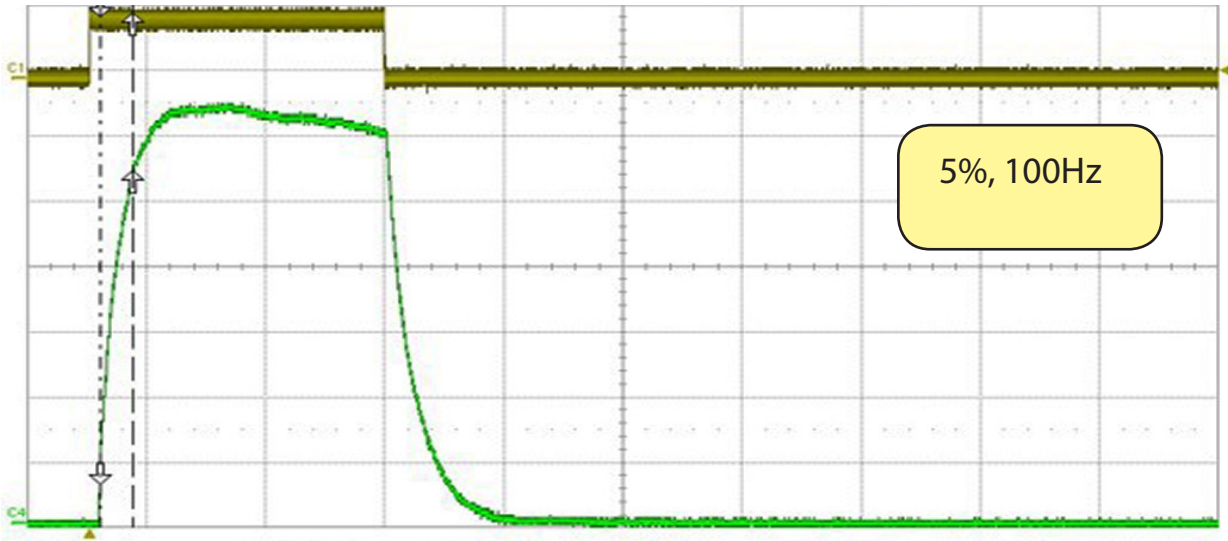

Figure 4-6 Representative output energy profile-5% duty cycle, 100Hz, time base 200 μs/Div.

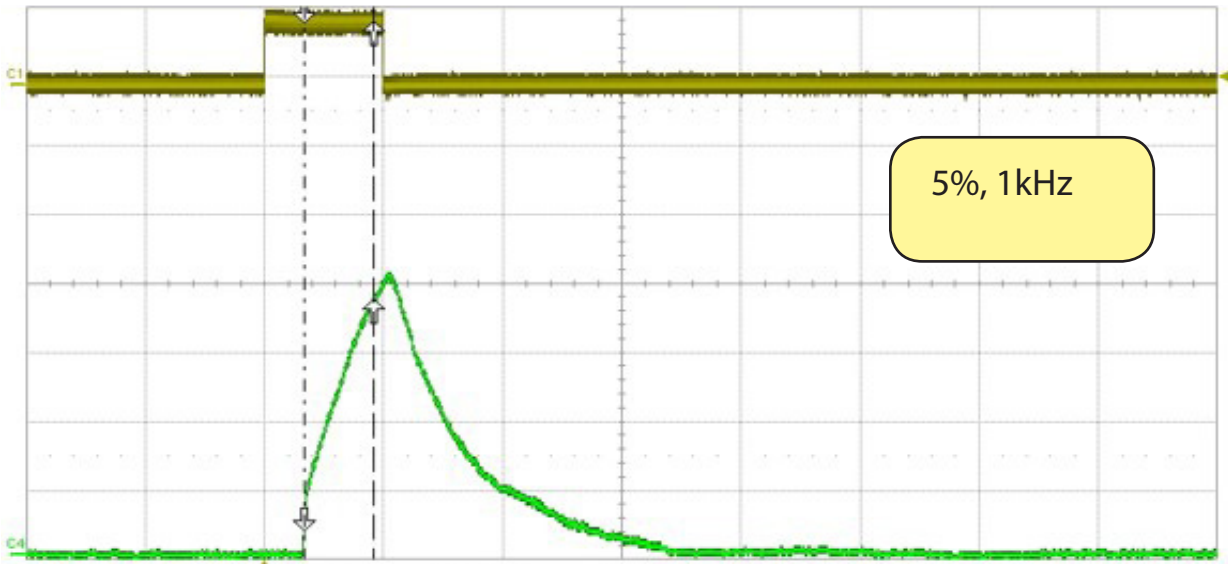

Figure 4-7 Representative output energy profile-5% duty cycle, 1kHz, time base 50 μs/Div.

Technical Reference

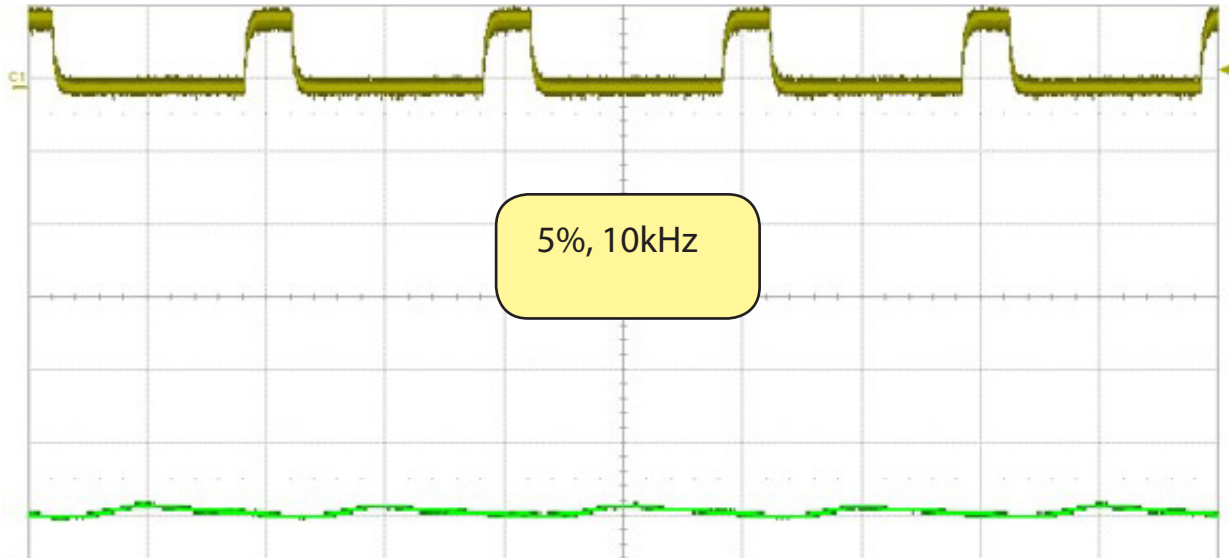

Figure 4-8 Representative output energy profile-5% duty cycle, 10kHz, 50 μ s/Div time base.

Figure below Shows details of the output energy waveform at approximately 85% of peak power.

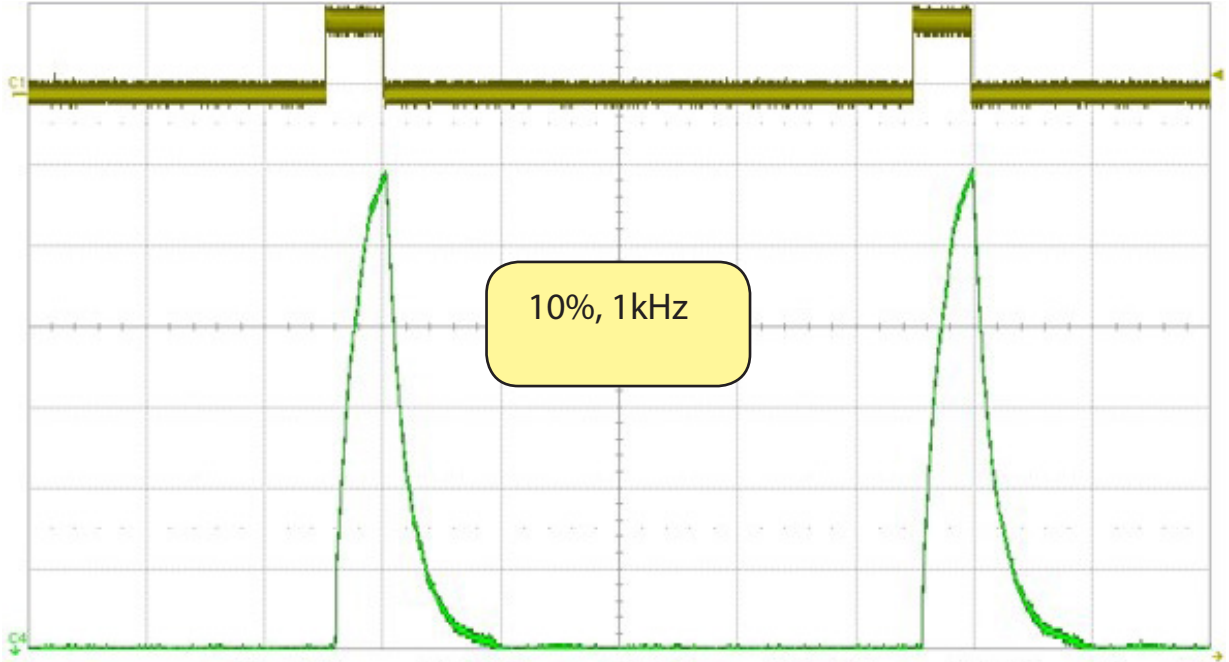

Figure 4-9 Representative output energy profile-10% duty cycle, 1kHz, 200 μ s/Div time base.

Technical Reference

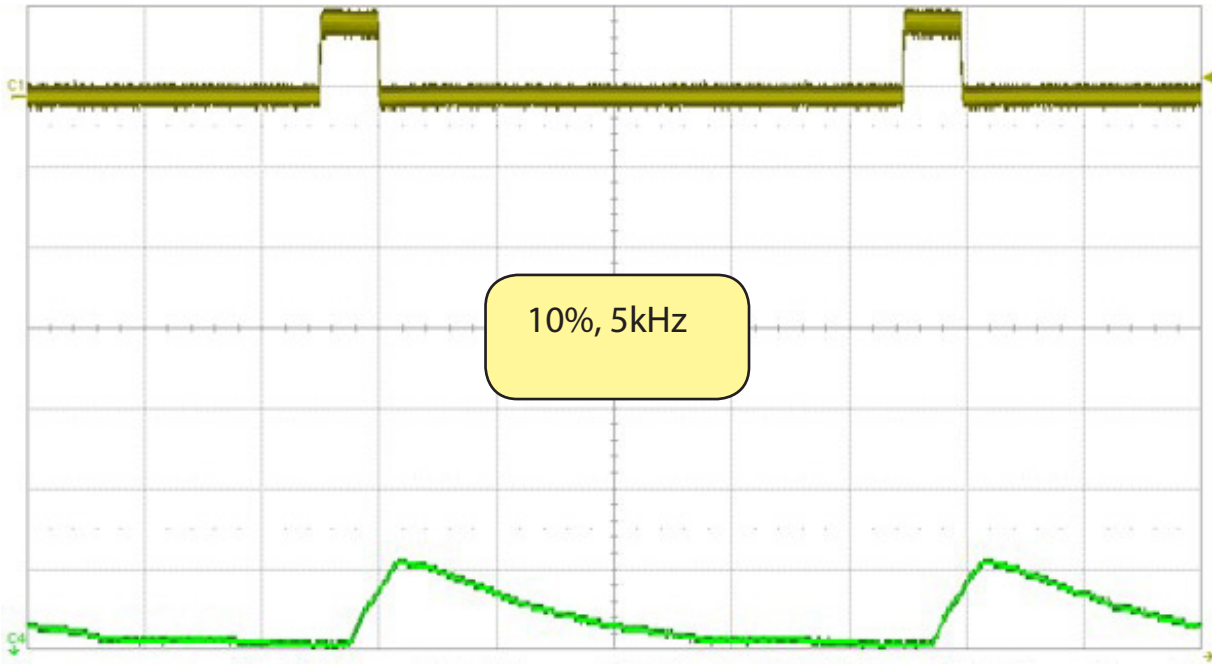

Figure 4-10 Representative output energy profile-10% duty cycle, 10 kHz, 20.0 μ s/Dev time base.

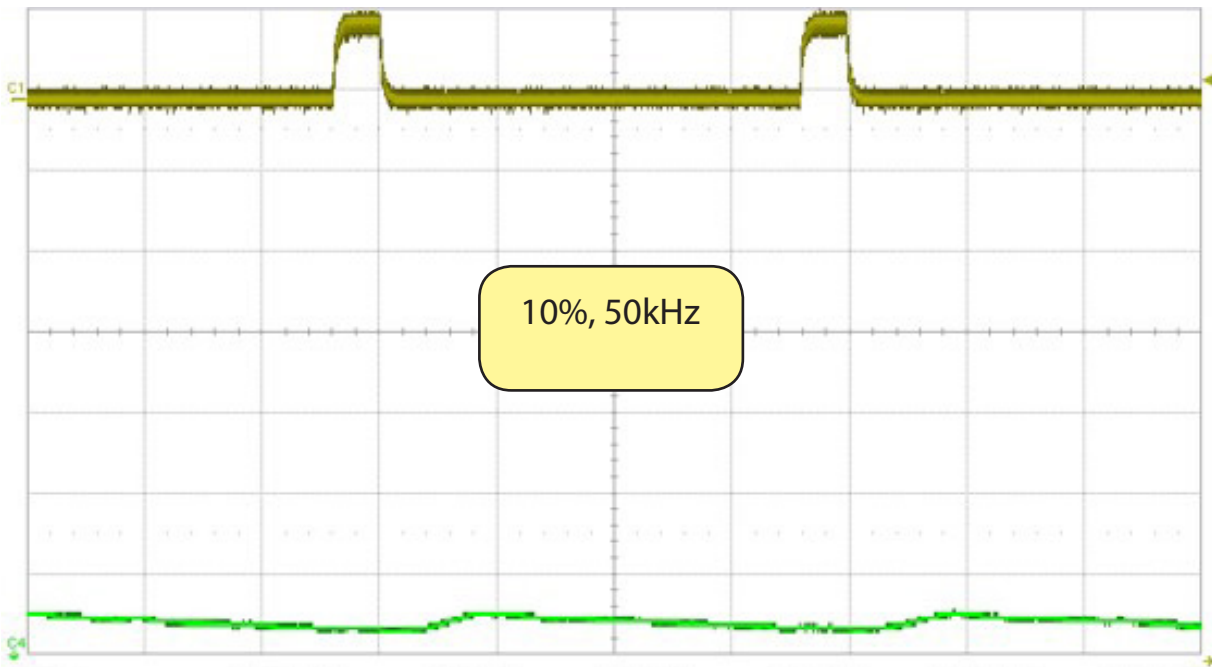

Figure 4-11 Representative output energy profile-10% duty cycle, 50 kHz, 5.0 μ s timebase.

Technical Reference

Figure below Shows pulsed output behavior with a 20% duty cycle at a frequency of 1kHz.

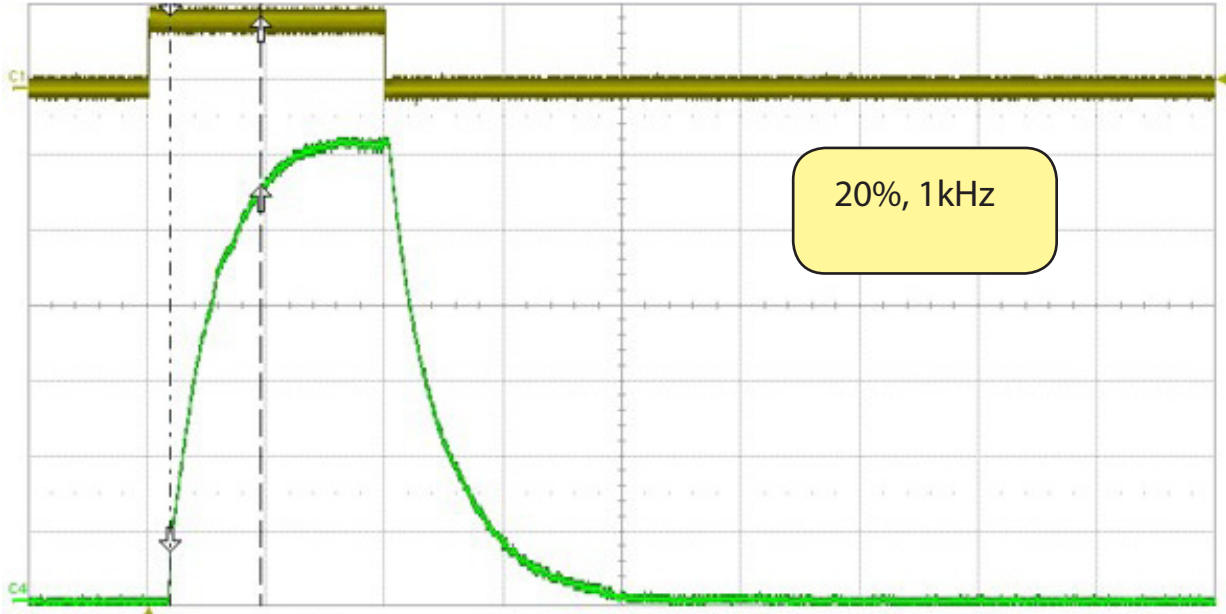

Figure 4-12 Representative output energy profile-20% duty cycle, 1 kHz, 100 μ s/Dev time base.

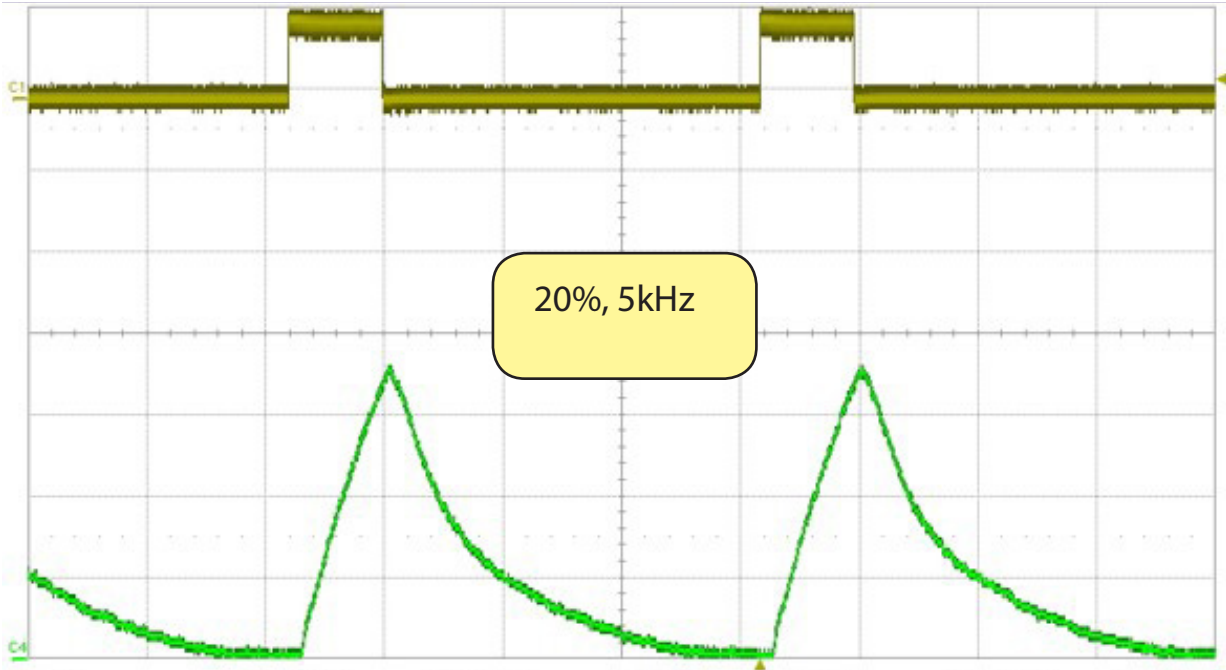

Figure 4-13 Representative output energy profile-20% duty cycle, 5 kHz, 50 μ s/Div time base.

Technical Reference

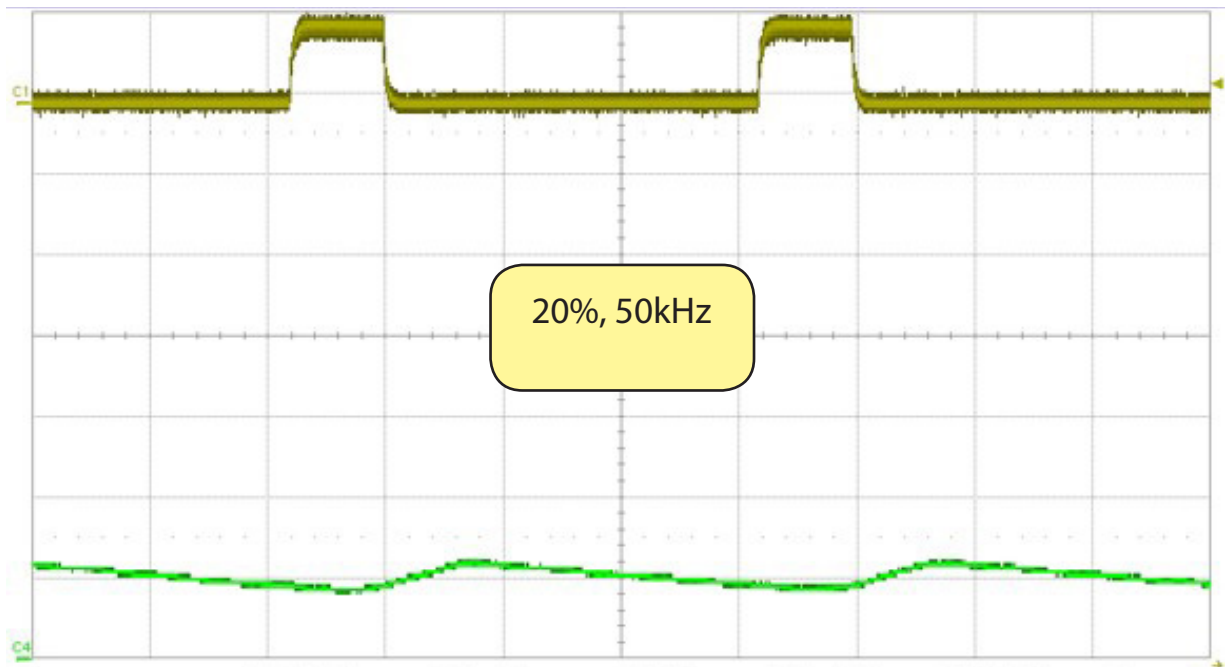

Figure 4-14 Representative output energy profile-20% duty cycle, 50 kHz, 5.0 μ s/Dev time base.

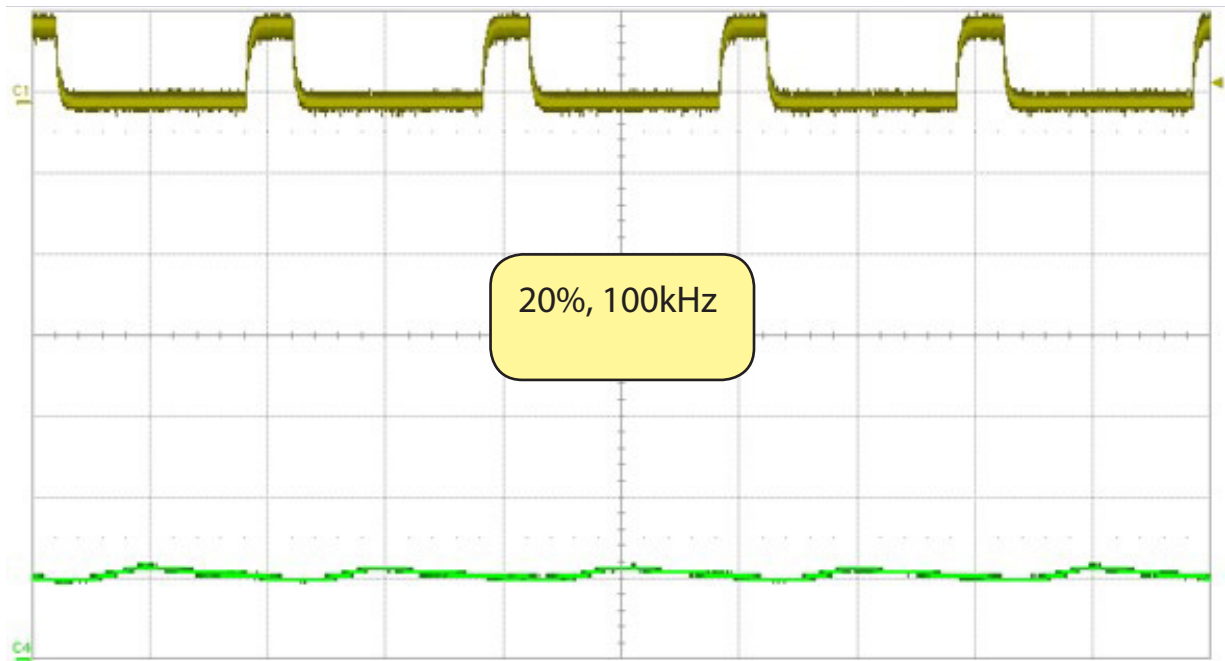

Figure 4-15 Representative output energy profile-20% duty cycle, 100 kHz, 5.0 μ s timebase.

Technical Reference

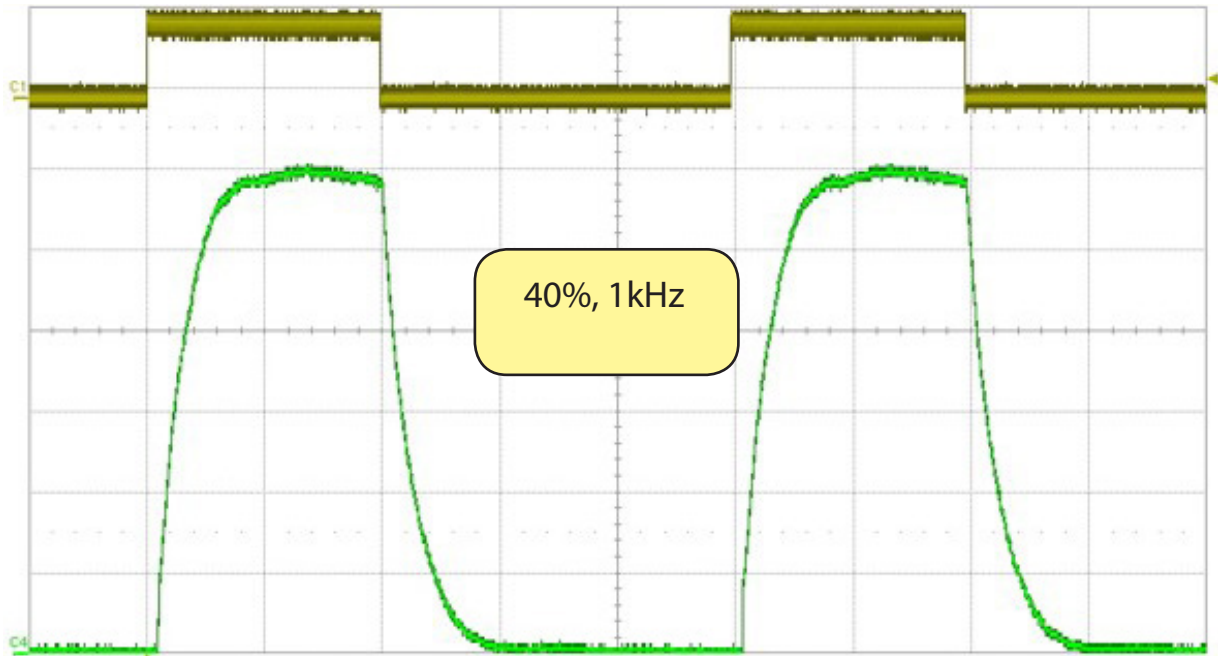

Figure 4-16 Representative output energy profile-40% duty cycle, 1 kHz, 200 μ s/Dev time base.

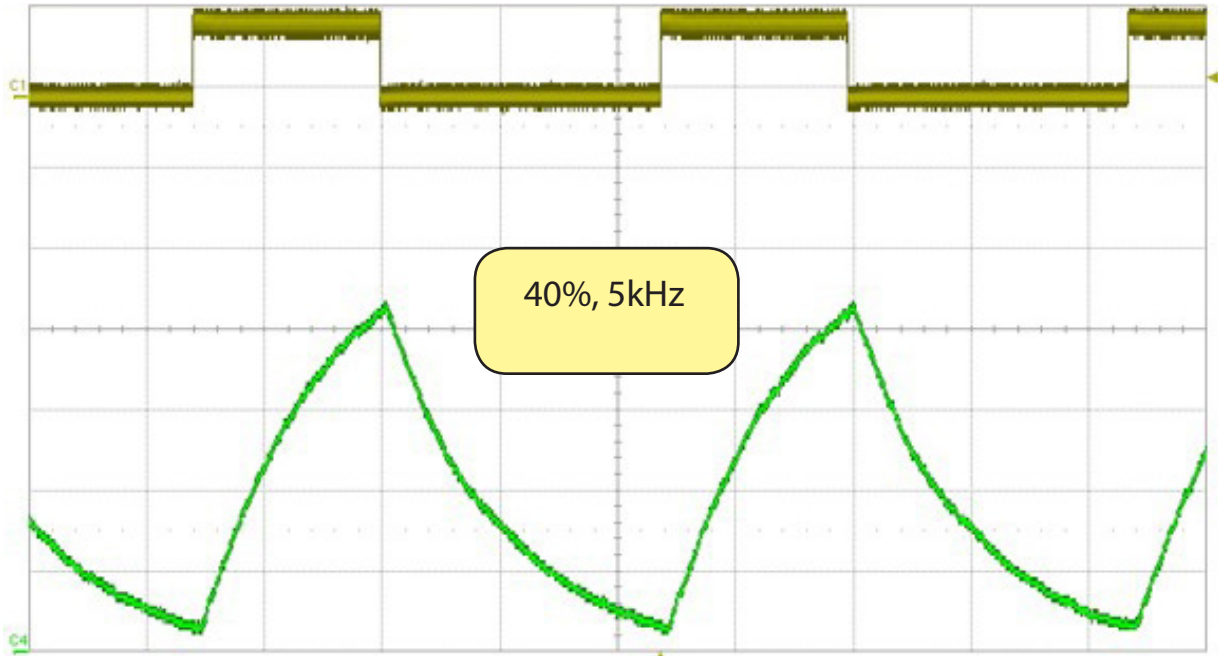

Figure 4-17 Representative output energy profile-40% duty cycle, 5 kHz, 50.0 μ s/Dev time base.

Technical Reference

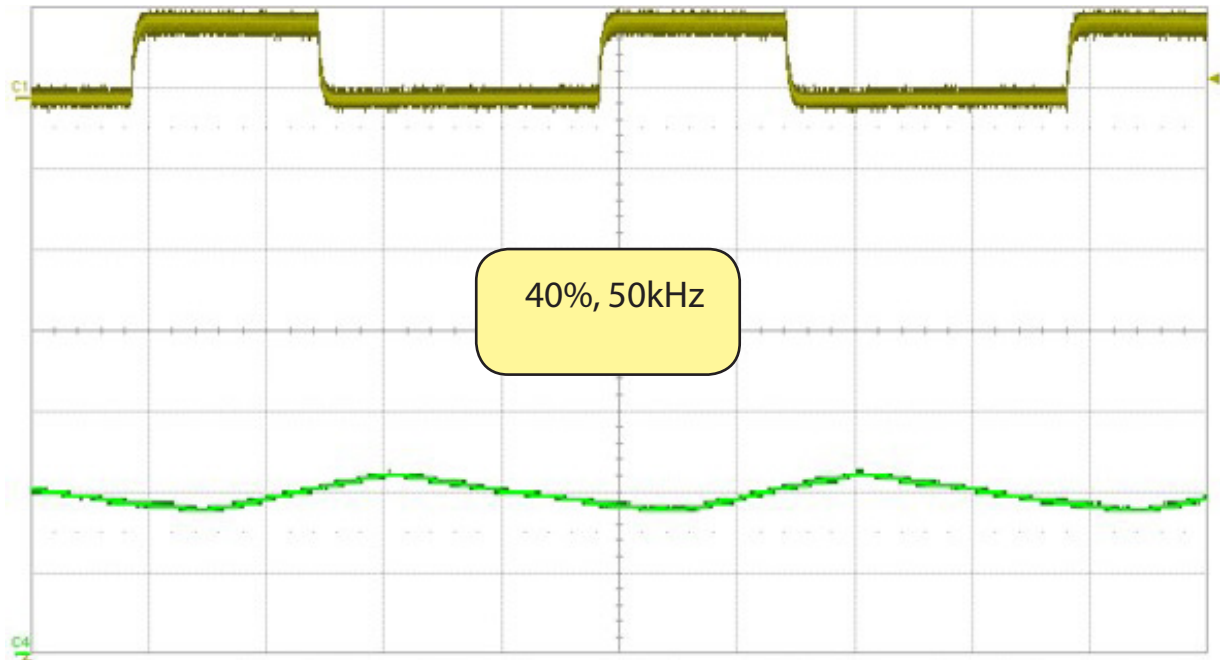

Figure 4-18 Representative output energy profile-40% duty cycle, 50 kHz, 5.0 μ s/Dev time base.

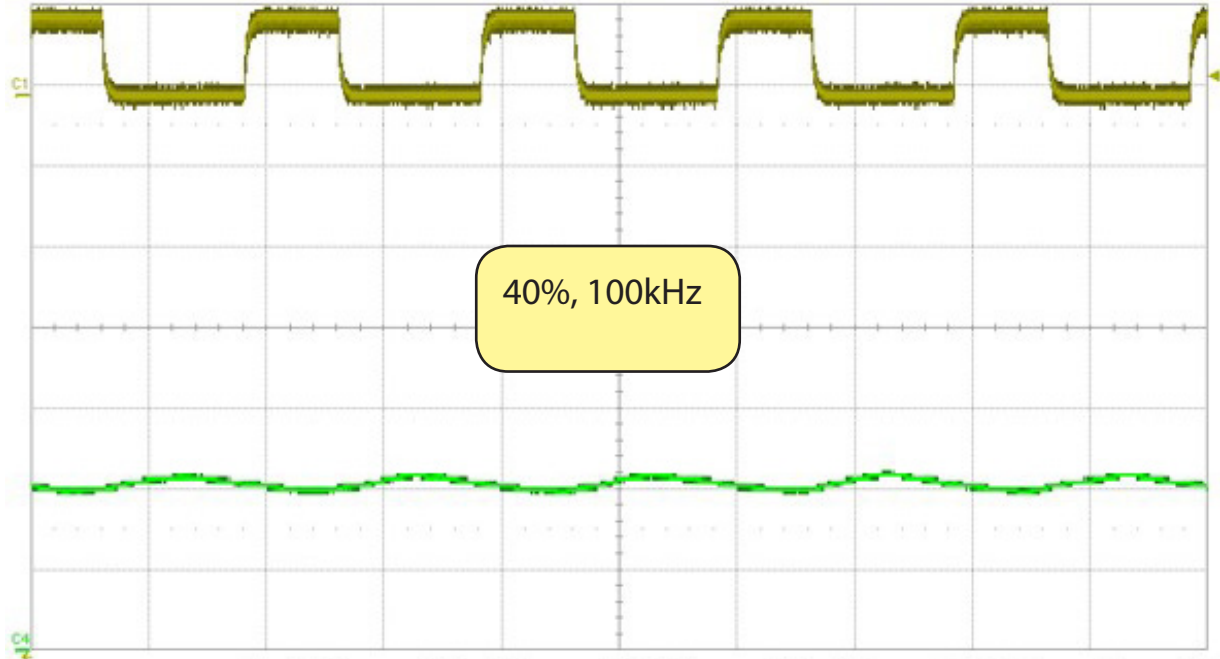

Figure 4-19 Representative output energy profile-40% duty cycle, 100 kHz, 5.0 μ s/Dev time base.

Technical Reference

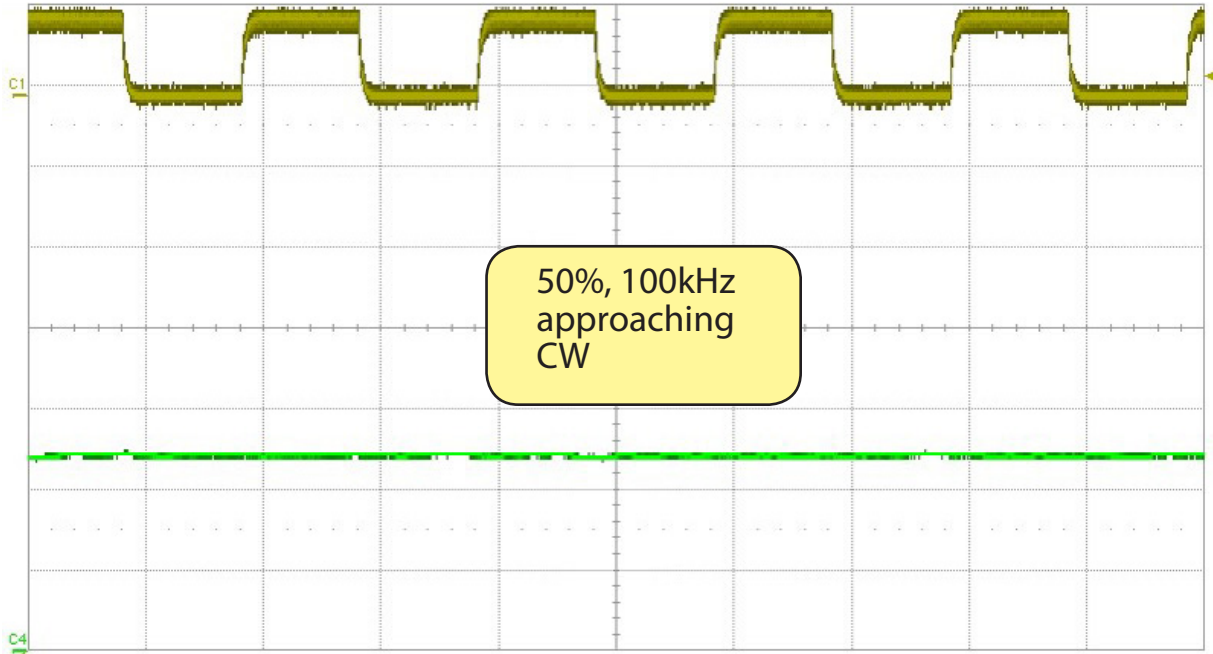

Figure 4-20 Representative output energy profile-50% duty cycle, 100 kHz, 5.0 μ s/Dev time base.

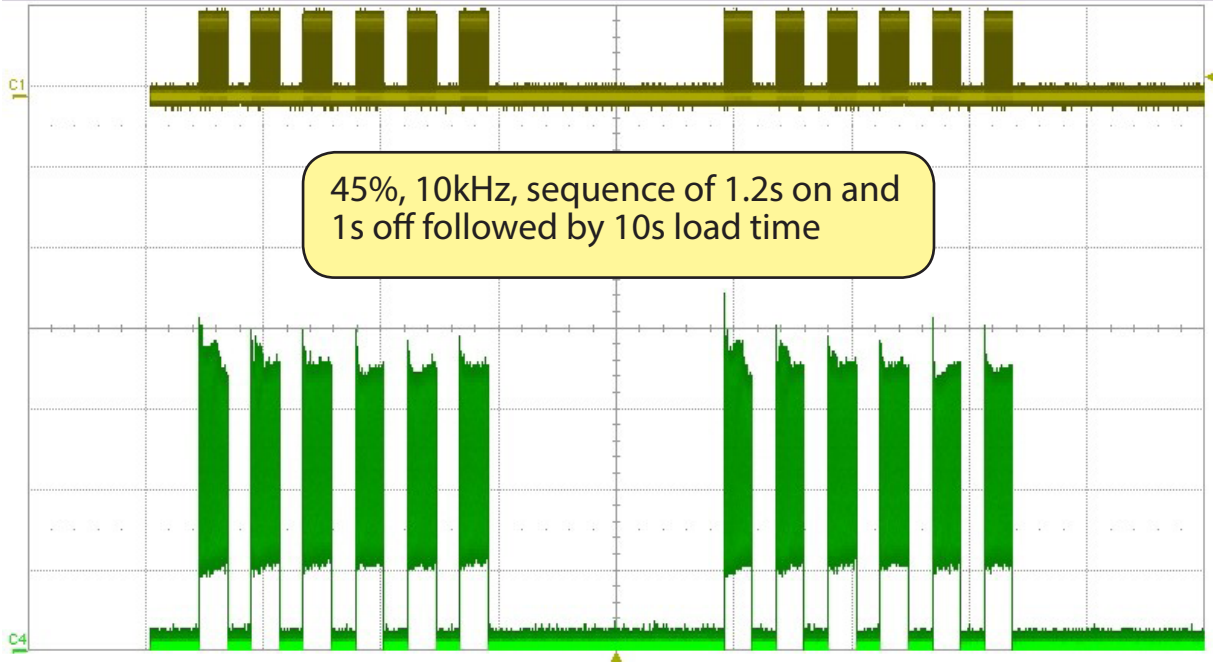

Figure 4-21 Representative output energy profile-45% duty cycle, 10 kHz, 5.0 μ s/Dev time base.

Technical Reference

The prior figures show the p250 laser delivering near peak output power. At a 10% duty cycle (at 1 kHz), the rise and fall time of the p250 limits depth of modulation to approximately 85% of peak power. At 20% duty cycle (at 1 kHz), p250 laser delivers peak output power at full depth of modulation.

Marking/engraving operation

When the delay between the end of one PWM Command signal pulse and the beginning of the next PWM pulse exceeds 200 microseconds (less than or equal to 5 kHz), Pulstar's on-board tickle generator sends a tickle pulse to maintain plasma ionization in the tube. Because the on-board tickle generator cannot anticipate when the next PWM Command pulse will arrive; the tickle pulse (which typically lasts for 2–6 μ s depending on the laser) can effectively merge with a PWM signal that follows closely afterwards. When the PWM pulse that follows is short, causing the tickle pulse to become a significant fraction of the PWM pulse duration, then the tickle pulse effectively substantially increases the length of the PWM pulse it has merged with. For subtle marking applications on sensitive, low threshold materials this lengthened PWM pulse may affect mark quality.

While this situation can occur when using PWM Command signal frequencies of 5 kHz and less, it is important to note that it isn't the Command signal frequency itself that is the determining factor but rather this behavior happens only when the off time between PWM pulses exceeds 200 microseconds.

Technical Reference

User I/O connections

- User I/O connection summary
- Input/output signals
- Sample I/O circuits

The PWM Command signal and all input/output (I/O) control signals are connected to the User I/O port. Please refer to the figure below for the 15 pin female D-type sub-miniature connector on the p250's rear panel. The figure below illustrates the pin arrangement of the User I/O connector.

Caution
Possible Equipment Damage



Turn off DC power before installing or removing any plug or cable from the User I/O connector.

Ensure that user connections are made to the appropriate pins and that the appropriate signal levels are applied.

Failure to do so may damage the laser.

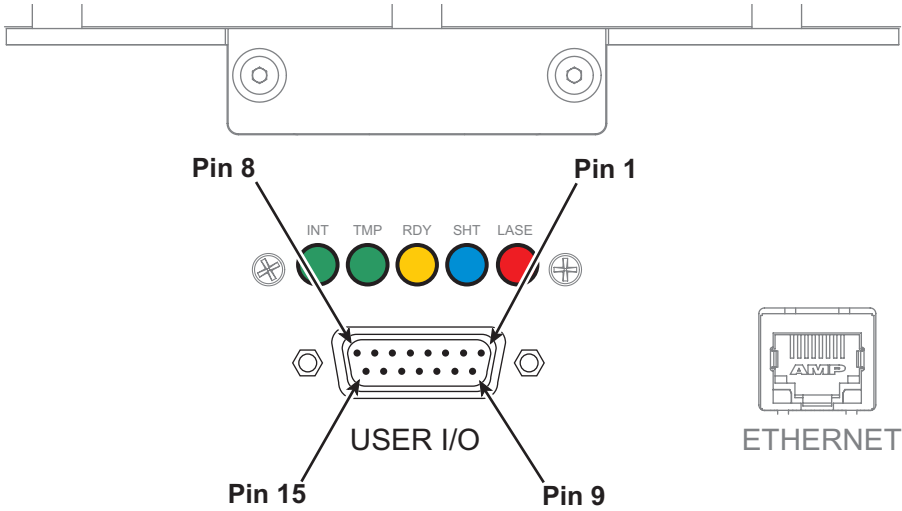

Figure 4-22 User I/O connector pinouts.

User I/O connection summary

The following user I/O pin descriptions table provides a quick reference summary to Pulstar p250 User I/O connections.

Technical Reference

Table 4-4 User I/O pin descriptions.

Pin	Function	Description
1	PWM Return	Use this input pin as the return side of the PWM Command Signal.
2	Remote Reset/ Start Request input	Apply a positive or negative voltage ($\pm 5-24$ VDC) with respect to Pin 11, Input Common, to reset or remote keys with the laser. The laser remains disabled while voltage is applied. Removing voltage from the Remote Reset/Start Request input causes the laser's RDY indicator to illuminate and begins a five-second countdown after which lasing is enabled.
<p>Note: When connecting field wiring to the Remote Reset/Start Request input, use twisted pair and/or shielded cabling. Refer to SYNRAD Technical Bulletin #021 for details.</p>		
3	Remote Interlock input	Apply a positive or negative voltage ($\pm 5-24$ VDC) with respect to Pin 11, Input Common, to enable lasing. If your system does not use a remote interlock, this pin must be connected to a voltage source in the range of $\pm 5-24$ VDC. Refer to following figure for a diagram showing how the Remote Interlock input is factory-jumpered on the Quick Start Plug.
4	+ 5 VDC Auxiliary Power	This connection provides +5 VDC for driving external inputs or outputs. The +5 VDC Auxiliary Power output can source up to 0.5 A and is protected by a 0.5 A self-resetting fuse. The return (ground) path must be through Pin 12, Auxiliary DC Power Ground.
5	+ 24 VDC Auxiliary Power	This connection provides +24 VDC for driving external inputs or outputs. The +24 VDC Auxiliary Power output can source up to 0.5 A and is protected by a 0.5 A self-resetting fuse. The return (ground) path must be through Pin 12, Auxiliary DC Power Ground.
6	Laser Active Output	This bi-directional switched output is internally connected to Pin 13, Output Common, when the laser is actively lasing (LASE indicator illuminated red). This output is open (high impedance) when no beam is being emitted (LASE indicator Off).
7	Fault Detected Output	This bi-directional switched output is internally connected to Pin 13, Output Common, when (1) laser temperature is above safe operating limits (TMP LED illuminated red) or (2) a No-Strike condition has occurred (blue SHT indicator is flashing). The output is open (high impedance) when laser operation is within limits (TMP LED green and SHT LED blue).
8	Laser Ready Output	This bi-directional switched output is internally connected to Pin 13, Output Common, when the laser is enabled (RDY LED illuminated yellow), indicating that lasing will occur when a PWM Command signal is applied to Pin 9 and Pin 1. When this output is initially switched closed, there is a five-second delay during which lasing is inhibited. This output is open (high impedance) when the laser is disabled (RDY indicator Off).

Technical Reference

Table 4-4 User I/O pin descriptions (Continued).

Pin	Function	Description
9	PWM Input	Connect your PWM Command signal (+5 VDC, 5 kHz nominal, 100 kHz max, pulse width modulated) to this input pin to control laser output power. Refer back to Controlling laser power for further information on laser control signals.
10	Shutter Open Request input	Apply a positive or negative voltage (± 5 –24 VDC) with respect to Pin 11, Input Common, to enable the laser. This input is also used to actuate the optional EM shutter if your laser is so equipped. If your system does not supply a Shutter Open Request signal, this pin must be connected to a voltage source in the range of ± 5 –24 VDC. Refer to the prior figures for a diagram showing how the Shutter Open Request input is factory-jumpered on the Quick Start Plug. The shutter will not activate until a voltage is also applied to the Remote Interlock input (INT LED illuminated green and RDY LED On).
11	Input Common	Use this input pin to connect return lines for Remote Interlock, Shutter Open Request, and Remote Reset/Start Request lines.
12	Auxiliary DC Power Ground	This connection provides a ground (earth) connection for +5 and +24 VDC auxiliary power outputs. This pin is the only User I/O pin that is connected to chassis ground. Do not use this pin for grounding if DC power to external I/O circuits is supplied from an external customer-supplied DC power source.
13	Output Common	Use this pin to complete the return path for output connections (Pin 6, 7, 8, 14, or 15). The Output Common line is protected by a 0.3 A self-resetting fuse.
14	Shutter Open Output	This bi-directional switched output is internally connected to Pin 13, Output Common, when Remote Interlock <u>and</u> Shutter Open Request signals are present (RDY indicator illuminated yellow and SHT indicator blue) to indicate that the shutter is open and lasing is enabled. This output is open (high impedance) when the laser is disabled (SHT indicator Off).
15	Interlock Open Output	This bi-directional switched output is internally connected to Pin 13, Output Common, when remote interlock circuitry is open (INT indicator illuminated red), indicating that lasing is disabled. The output is open (high impedance) when lasing is enabled (INT indicator green).

Input/output signals

The Pulstar p250's input/output signals are divided into three categories: auxiliary DC power, input signals, and output signals. Signals in each category are fully described in the following sections.

Technical Reference

Auxiliary DC power

Pulstar’s User I/O connector provides auxiliary DC power for driving external inputs or outputs connected to the User I/O port. Pin 4, +5 VDC Auxiliary Power, and Pin 5, +24 VDC Auxiliary Power, are protected by self-resetting fuses rated at 0.5 A. Pin 12, Auxiliary DC Power Ground, is connected to chassis ground while all other User I/O pins are floating with respect to chassis ground. The figure below illustrates Pulstar’s internal DC supply wiring.

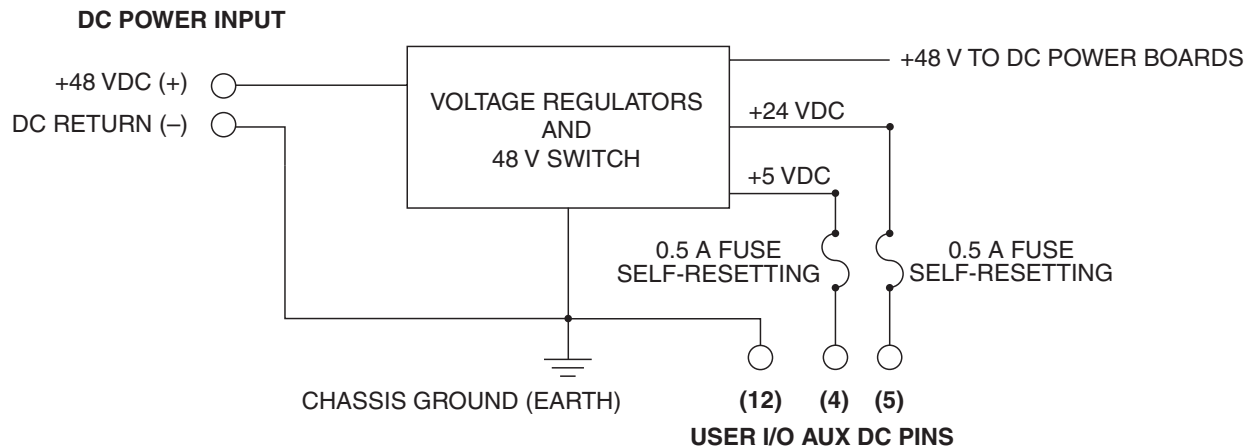

Figure 4-23 Auxiliary DC power diagram.

Table 4-4 User I/O pin descriptions (Continued).

Pin	Function	Description
Pin 4	+ 5 VDC Auxiliary Power	This connection provides +5 VDC for driving external inputs or outputs. The +5 VDC Auxiliary Power output can source up to 0.5 A and is protected by a 0.5 A self-resetting fuse. The return (ground) path must be through Pin 12, Auxiliary DC Power Ground.
Pin 5	+ 24 VDC Auxiliary Power	This connection provides +24 VDC for driving external inputs or outputs. The +24 VDC Auxiliary Power output can source up to 0.5 A and is protected by a 0.5 A self-resetting fuse. The return (ground) path must be through Pin 12, Auxiliary DC Power Ground.
Pin 12	Auxiliary DC Power Ground	This connection provides a ground (earth) connection for +5 and +24 VDC auxiliary power outputs. This pin is the only User I/O pin that is connected to the laser’s chassis ground. Do not use this pin for grounding if I/O circuits are powered from an external customer-supplied DC power source.

Technical Reference

Input signals

A total of four user inputs allow control of Pulstar lasers. Remote Interlock, Shutter Open Request, and Remote Reset/Start Request inputs are optoisolated and bi-directional, allowing for positive or negative polarity signal inputs. These three signals also share a common return connection, Input Common, which is separate from chassis ground to completely isolate control signals for optimal EMI performance. The fourth input, PWM Input, is optoisolated and has a separate return, PWM Return, to fully isolate PWM signals from the other three user inputs. Note that throughout this manual, input voltage levels are specified with respect to their corresponding return line.

Table 4-4 User I/O pin descriptions (Continued).

Pin	Function	Description
Pin 1	PWM Return	Connect the return side of your PWM Command signal to this pin. Refer to the following input circuit specifications table.
Pin 2	Remote Reset/Start Request	Apply a positive or negative voltage (± 5 –24 VDC) with respect to Pin 11, Input Common, to disable the laser. The laser remains disabled while voltage is applied to this pin. Removing voltage from the Remote Reset/Start Request pin causes the laser's RDY lamp to illuminate and begins a five-second countdown after which lasing is enabled. Because all DC power is removed from the laser's RF modules when this input is active, no lasing can occur until voltage is removed from Pin 2. Refer to the following input circuit specifications table.

Note: When connecting field wiring to the Remote Reset/Start Request input, use twisted pair and/or shielded cabling. Refer to SYNRAD Technical Bulletin #021 for details.

Pin 3	Remote Interlock	Apply a positive or negative voltage (± 5 –24 VDC) with respect to Pin 11, Input Common, to enable lasing. If your system does not use a remote interlock, this pin must be connected to a voltage source in the range of ± 5 –24 VDC. Refer to the following figure for a diagram showing how the Remote Interlock input is factory-jumpered on the Quick Start Plug to enable lasing and for troubleshooting purposes. Because all DC power is removed from the laser's RF modules when this input is inactive, no lasing can occur until voltage is applied to Pin 3. Refer to Table 5-4 for input circuit specifications.
-------	------------------	--

Remote Interlock faults (INT LED illuminates red) are not latched. Re-applying a voltage to Pin 3 enables the RDY indicator and lasing is possible after the five-second delay, provided that the SHT indicator is also lit.

Note: Use the interlock function to provide maximum operator safety. When the Remote Interlock input is opened (voltage source removed), the internal shutter automatically closes to block the beam path, the RDY LED turns Off, the SHT LED turns Off (regardless of the state of the Shutter Open Request input), and all DC power is removed from the RF boards.

Technical Reference

Table 4-4 User I/O pin descriptions (Continued).

Pin	Function	Description
Pin 9	PWM Input	Connect your PWM Command signal (+5 VDC, 5 kHz nominal, 100kHz max) to Pin 9. This pulse width modulated Command signal controls laser output so that a duty cycle of 22.5% corresponds to a laser output of approximately one-half rated output power and a duty cycle of 50% corresponds to approximately full output power. Refer to Controlling laser power in this chapter for further information on laser control signals. Connect the PWM signal source return to Pin 1, PWM Return. See the input table 4.5circuit specifications.
Pin 10	Shutter Open Request	Apply a positive or negative voltage (± 5 –24 VDC) with respect to Pin 11, Input Common, to open the internal EM shutter assembly (when the Remote Interlock input is active). If your system does not supply a Shutter Open Request signal, then this pin must be connected to a voltage source in the range of ± 5 –24 VDC. Figure below illustrates how the Remote Interlock and Shutter Open Request inputs are factory-jumpered on the Quick Start Plug enable lasing for initial testing and troubleshooting purposes. See the following input circuit specifications.

Warning
Serious personal injury



The use of the Quick Start Plug bypasses the laser's safety interlock function, potentially exposing personnel in the area to invisible infrared laser radiation.

The Quick Start Plug is intended only for initial testing and troubleshooting by qualified personnel. In normal operation, the laser's Remote Interlock input should be connected to the machine's safety interlock circuitry.

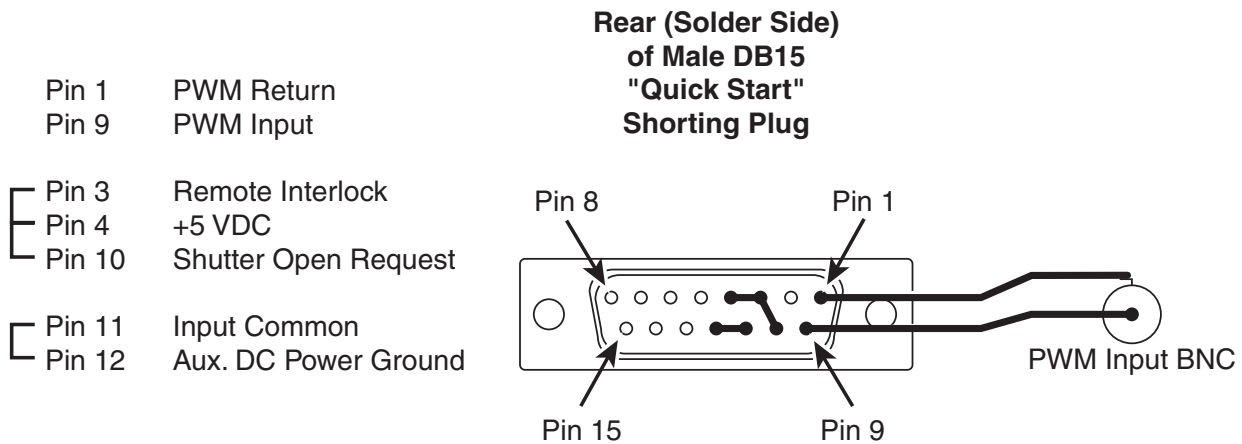

Figure 4-24 Quick Start Plug wiring diagram.

The following figure illustrates the input circuit's equivalent internal schematic while the following table provides Pulstar p250 input circuit specifications.

Technical Reference

Table 4-4 User I/O pin descriptions (Continued).

Pin	Function	Description
Pin 11	Input Common	Use this pin to connect return lines for Remote Interlock, Shutter Open Request, and Remote Reset/Start Request lines. Refer to following table for input circuit specifications.

Note: Shutter Open Request and Remote Interlock inputs are dependent control functions. The internal shutter mechanism will not activate (open) until a voltage is also applied to the Remote Interlock input (causing INT LED to illuminate green and RDY LED to turn On).

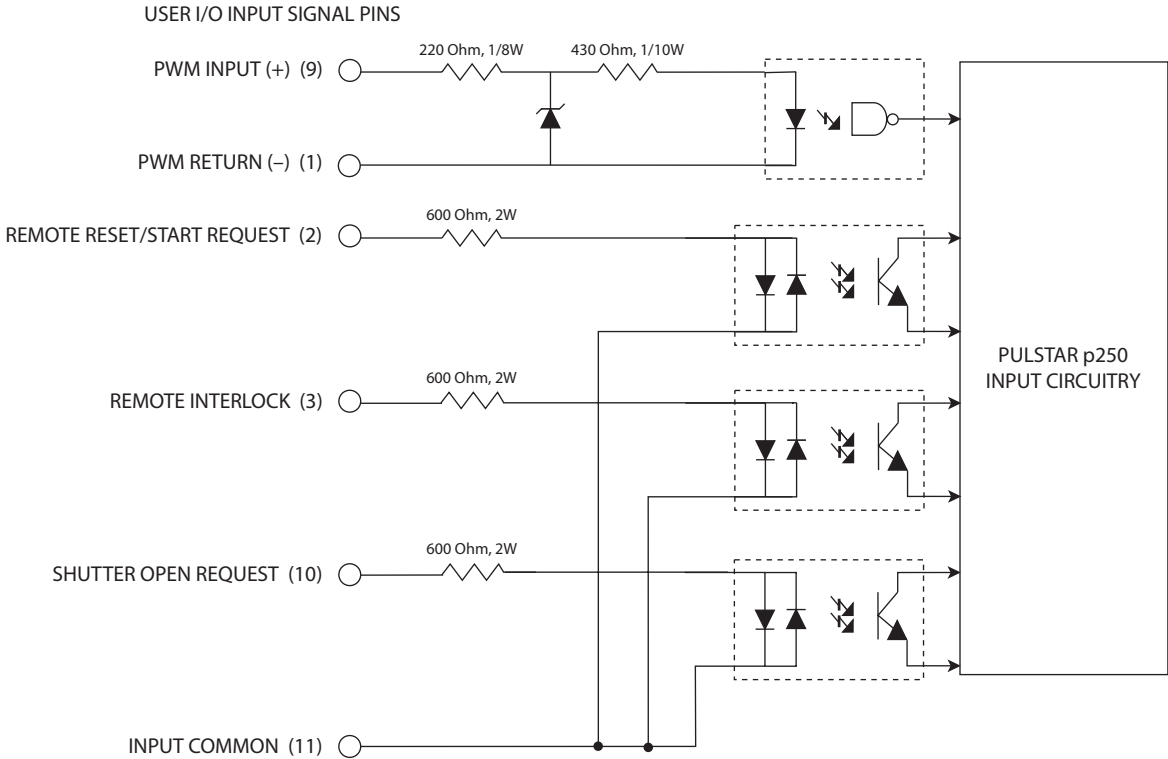

Figure 4-25 Input equivalent schematic.

Technical Reference

Table 4-5 Input circuit specifications.

Input Signal Name	Input Device Type and Specifications
PWM Input	High-speed optoisolator LED, forward voltage drop (V_f) 1.5 VDC Off state V_{max} +0.8 VDC On state V_{min} +3.5 VDC @ 3 mA On state (continuous) V_{max} +6.7 VDC @ 10 mA Frequency, max. 100 kHz Max PWM = 45% Max Pulse Length = 1 millisecond
Remote Reset/Start Request	Bi-directional optoisolator LED, forward voltage drop (V_f) 1.15 VDC
Remote Interlock	Off state V_{max} < 1.0 VDC
Shutter Open Request	On state V_{min} \pm 5.0 VDC @ 7 mA On state (continuous) V_{max} \pm 24.0 VDC @ 40 mA

Note: The Remote Reset/Start Request input must not be sent until Pulstar's +5 VDC power supply has stabilized (approximately 200 ms after DC power-up).

Output signals

Pulstar's five user outputs correspond to the status functions described below. These outputs are optoisolated solid-state relays that allow for high-side or low-side switching. The shared connection, Output Common, is separate from the laser's chassis ground to allow high-side or low-side switching and to isolate control signals for optimum EMI performance.

Pulstar's optically-isolated outputs are useful for sending laser status to a Programmable Logic Controller (PLC) or computerized control system. Each of the five outputs can source 50 mA at \pm 24 VDC maximum for a total load of 250 mA. For controlling larger loads, use these outputs to drive a control relay.

Technical Reference

Note: Interlock Open and Shutter Open output signals are dependent control functions. The Shutter Open output will not close (SHT LED On) until a Shutter Open Request signal is applied and the Interlock Open output opens (causing INT LED to illuminate green and RDY LED to turn On).

Table 4-4 User I/O pin descriptions (Continued).

Pin 6	Laser Active	This bi-directional switched output is internally connected to Pin 13, Output Common, when the laser is actively lasing (LASE indicator red). This output is open (high impedance) when no beam is being emitted (LASE indicator Off). Refer to the following table for output circuit specifications.
Pin 7	Fault Detected	This bi-directional switched output is internally connected to Pin 13, Output Common, when (1) an over-temperature fault (TMP LED is red) or (2) a No-Strike condition (blue SHT indicator is flashing) has occurred. The output is open (high impedance) when laser operation is within limits (TMP LED green and SHT LED blue). Refer to the following table for output circuit specifications.
Pin 8	Laser Ready	This bi-directional switched output is internally connected to Pin 13, Output Common, when the laser is enabled (RDY indicator On), indicating that lasing will occur when a PWM Command signal is applied to Pin 9 and Pin 1. When this output is initially switched closed, there is a five-second delay during which lasing is inhibited. This output is open (high impedance) when the laser is disabled (RDY LED Off). Refer to the following table for output circuit specifications.
Pin 13	Output Common	Use this pin to complete the return (ground) path for any output connection (Pin 6, 7, 8, 14, or 15). The Output Common line is protected by a 0.3 A self-resetting fuse.
Pin 14	Shutter Open	This bi-directional switched output is internally connected to Pin 13, Output Common, when Remote Interlock <u>and</u> Shutter Open Request signals are present (SHT LED blue and RDY LED yellow), indicating that lasing is enabled. This output is open (high impedance) when the laser is disabled (SHT LED Off). Refer to the following table for output circuit specifications.
Pin 15	Interlock Open	This bi-directional switched output is internally connected to Pin 13, Output Common, when remote interlock input circuitry is open (INT indicator red), indicating that lasing is disabled. This output is open (high impedance) when the laser is enabled (INT indicator green). When this output is initially switched open, there is a five-second delay during which lasing is inhibited. See the following table for output circuit specifications.

Technical Reference

The figure below illustrates the output circuit's equivalent internal schematic and the table that follows provides Pulstar p250 output circuit specifications.

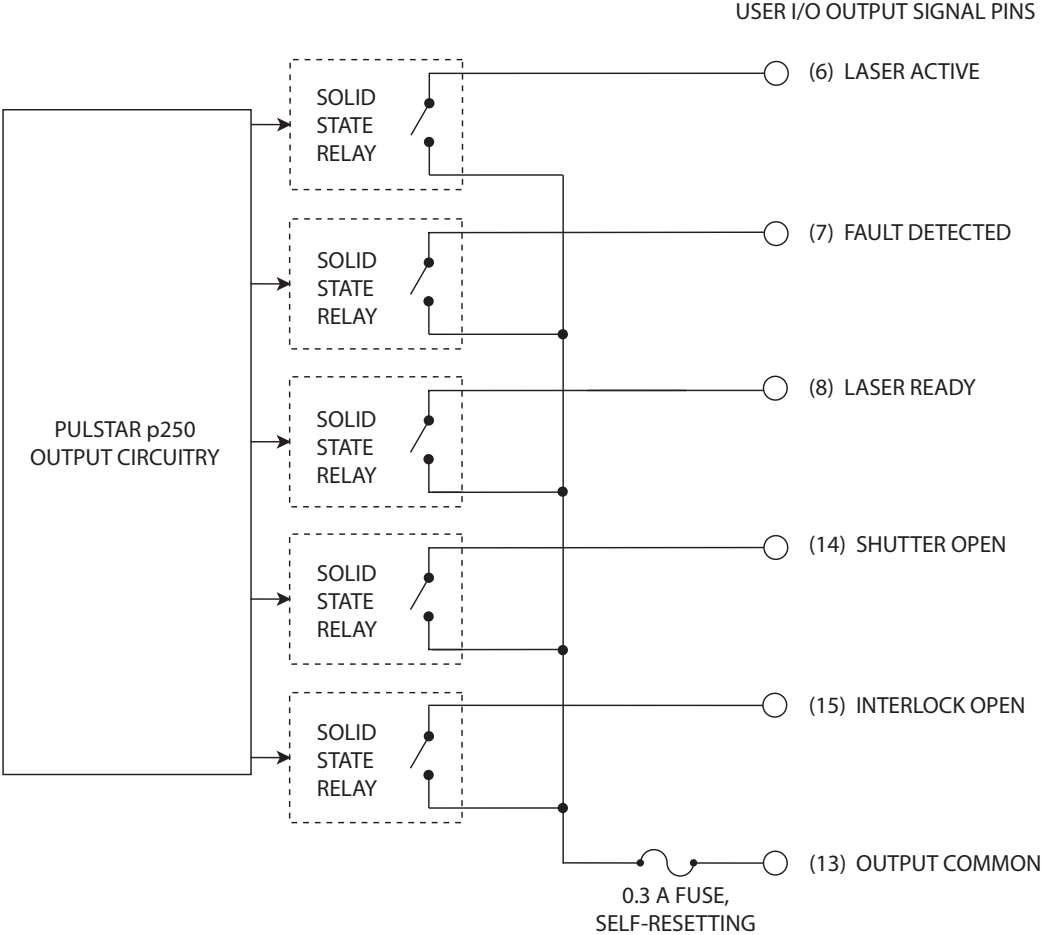

Figure 4-26 Output equivalent schematic.

Technical Reference

Table 4-6 Output circuit specifications.

Output Device	Specifications
Bi-directional MOSFET	2.5 Ohms Rdson 10 MOhms Off Voltage ± 24 VDC, max. Current 50 mA, max.

Sample I/O circuits

Sample inputs

The figure below illustrates one method of supplying a Remote Interlock signal using a customer-supplied limit switch. Pulstar's +24 VDC Auxiliary Power output powers the circuit. Note that Pin 4, +5 VDC Auxiliary Power, could have been used instead, depending on circuit voltage requirements.

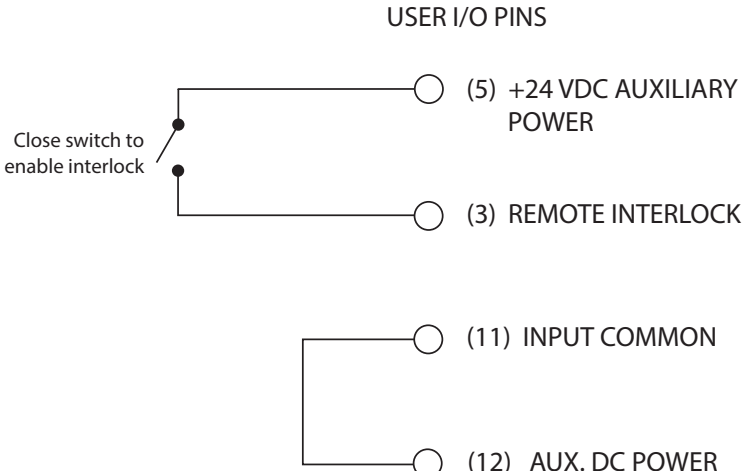

Figure 4-27 Customer-supplied interlock.

The following figure shows another variation for supplying a Remote Interlock signal to the laser. In this case, the customer is using a limit switch and supplying a negative voltage to drive Pulstar's input circuit.

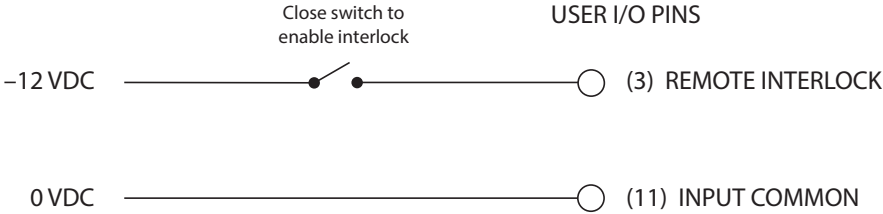

Figure 4-28 Customer-supplied interlock, negative voltage.

Technical Reference

A Programmable Logic Controller (PLC) can also drive Pulstar inputs. The figure below shows a typical method for connecting to a PLC output module when only one Pulstar input is used.

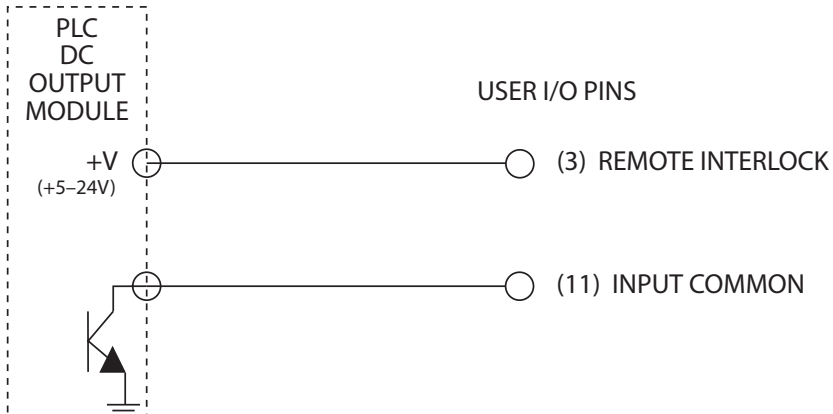

Figure 4-29 PLC driven interlock signal.

When multiple PLC outputs are used, connect Pulstar inputs to the PLC as shown in the figure below. By supplying voltage (+VDC) to Pin 11, Input Common, and pulling individual inputs to ground, each input can be independently activated by the PLC's output module.

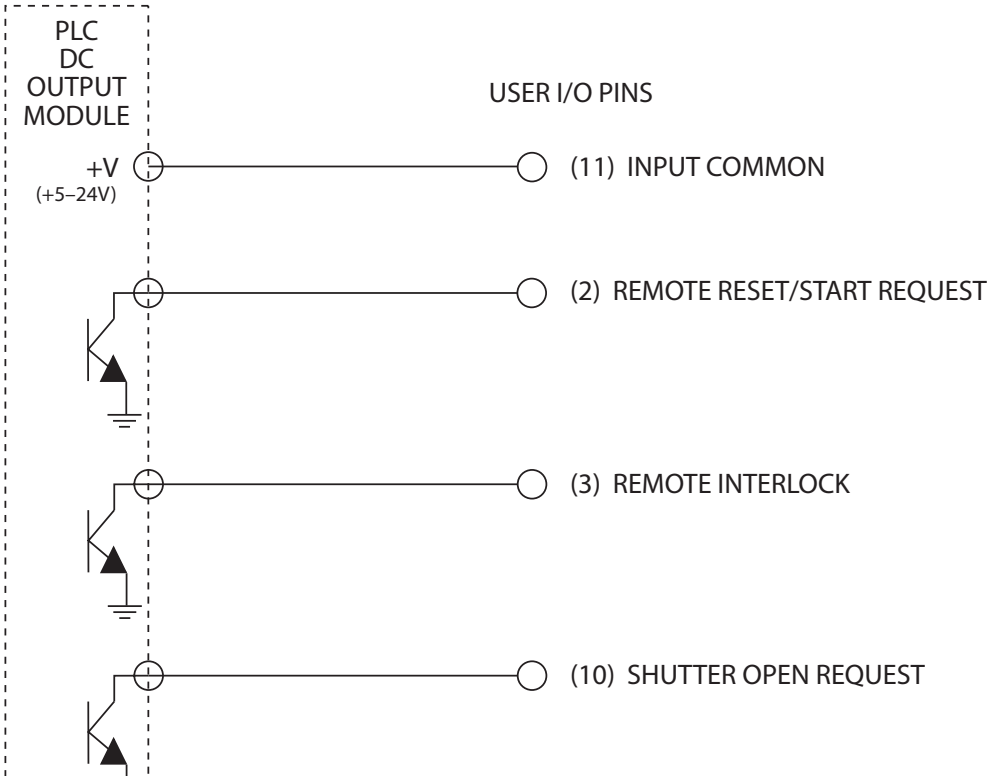

Figure 4-30 Multiple PLC driven inputs.

Technical Reference

Sample outputs

Pulstar's optoisolated, bi-directional switched outputs can drive small loads (50 mA max), PLC inputs, or relays that can control higher current loads. The following figure illustrates one method of controlling a remote warning lamp using power supplied by Pulstar's +24 VDC Auxiliary Power output. Remember to size current-limiting resistor, R1, so that the current draw does not exceed 50 mA.

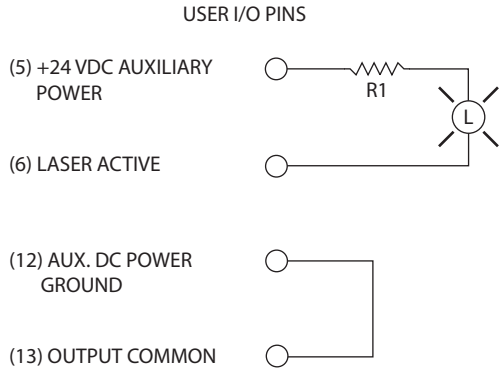

Figure 4-31 Pulstar output driving warning lamp.

Figure below illustrates a method for controlling a higher voltage, higher current load by using a 24V control relay. Ensure that the relay coil's pull-in current does not exceed 50 mA. A diode or surge suppressor must be installed across the relay coil to prevent voltage spikes from damaging Pulstar outputs.

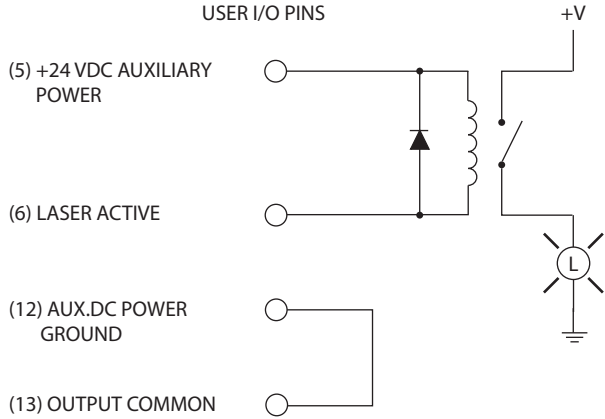

Figure 4-32 Pulstar output driving relay.

Technical Reference

Figure below illustrates how Pulstar's outputs can drive the DC Input Module of a Programmable Logic Controller (PLC). By supplying voltage (+VDC) to Pin 13, Output Common, each Pulstar output is independently switched to activate individual PLC inputs.

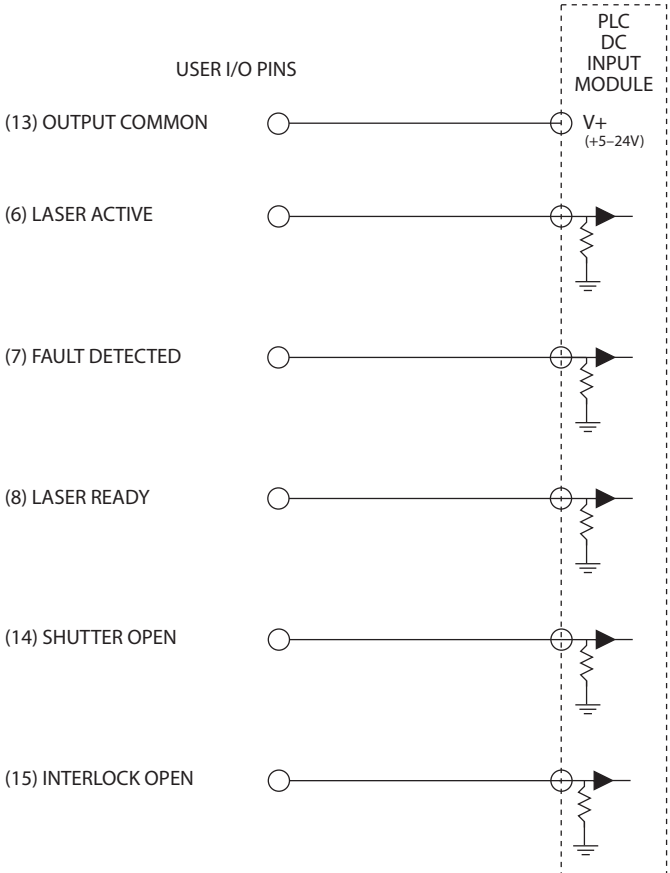

Figure 4-33 Pulstar output driving PLC input module.

Technical Reference

DC power cables

- DC power cables
- DC voltage sense cable

DC power cables

The DC power cables shipped with Pulstar p250 lasers are manufactured with 1/0 AWG wire to a standard length of 2.0 m (6.5 ft) or an optional length of 5.0 m (16 ft). Nominal finished O.D. is 14.9 mm (0.586") so the minimum bend radius must be greater than 12 cm (4.7 in). Terminals on the laser end of the cables fit the laser's M10 studs while terminals on the power supply ends are sized to fit M6 (0.25") bolts.

When using a power supply other than the PS-401, we recommend using remote sensing so the power supply output remains at a constant voltage over varying load conditions. Choose a DC supply that can compensate for a minimum load lead loss (round trip) of 1.0 V.

Important Note:



If you lengthen the DC Power Cables shipped with the p250 laser, you must calculate and measure the additional voltage drop to ensure that 48.0 VDC is available at the laser's +48V POWER terminal under full-load conditions. Keep in mind, depending on the additional length required, you may need to use larger gauge (2/0) wire.

Technical Reference

Pulstar p250 web interface

- Accessing the p250 web page
- Home page layout
- Event log page layout
- Changing the p250's IP address
- Alternate Ethernet connection

Important Note:  **The p250 web interface is not compatible with the Google Chrome browser.**

Connection to a local network is permitted as long as the laser's fixed IP address is unique to your network, otherwise a peer-to-peer connection is required. When connecting to a local network, use a straight-through Ethernet cable between the p250 laser and your Ethernet router or hub.

Accessing the p250 web page

Pulstar p250 lasers are pre-configured with a fixed IP address that allows a simple Ethernet connection between the p250 laser and a host. To connect your host computer to the p250 laser using a peer-to-peer Ethernet connection, perform the steps in the following sections.

Note: The following procedure may require the assistance of your IT Department if your facility's Ethernet settings are determined automatically using Dynamic Host Configuration Protocol (DHCP).

The p250 peer-to-peer Ethernet connection must be connected to a computer with a static IP address that is not connected to a local network.

Set your computer's static IP address

Note: The exact steps may vary depending on your operating system.

1. Disconnect the computer from your local network by removing any networking cables.
2. From the Start menu, go to Settings and choose Network Connections.
3. Double-click on the appropriate Local Area Network (LAN).
4. Locate the LAN's Internet Protocol (TCP/IP) properties.

Technical Reference

Set your computer's static IP address continued

5. Select "Use the following IP address:" and enter the following information. When done, click OK to submit the changes:

IP Address:	192.168.50.100
Subnet Mask:	255.255.255.0

Connect to the Pulstar p250 laser

1. Remove DC power from the laser.
2. Locate the Ethernet crossover cable in the ship kit.
3. Connect the crossover cable between your computer and the p250's Ethernet port.
4. Apply 48 VDC power to the laser.
5. Launch your web browser, type "http://192.168.50.50" (without the quotes,) and then press Enter.

Home page layout

Pulstar p250 lasers feature a web-based Internet interface that allows you to access read-only information about LED and RF module status—including voltage, current, and temperature measurements—using a standard web browser as shown in the following figure.

Note: The Ethernet cable included in the laser's ship kit is a shielded crossover cable. If your network application requires a straight-through (patch) cable or you supply your own crossover cable, be sure the Ethernet cable is an industrially-shielded CAT 5e or CAT 6 cable.

Technical Reference

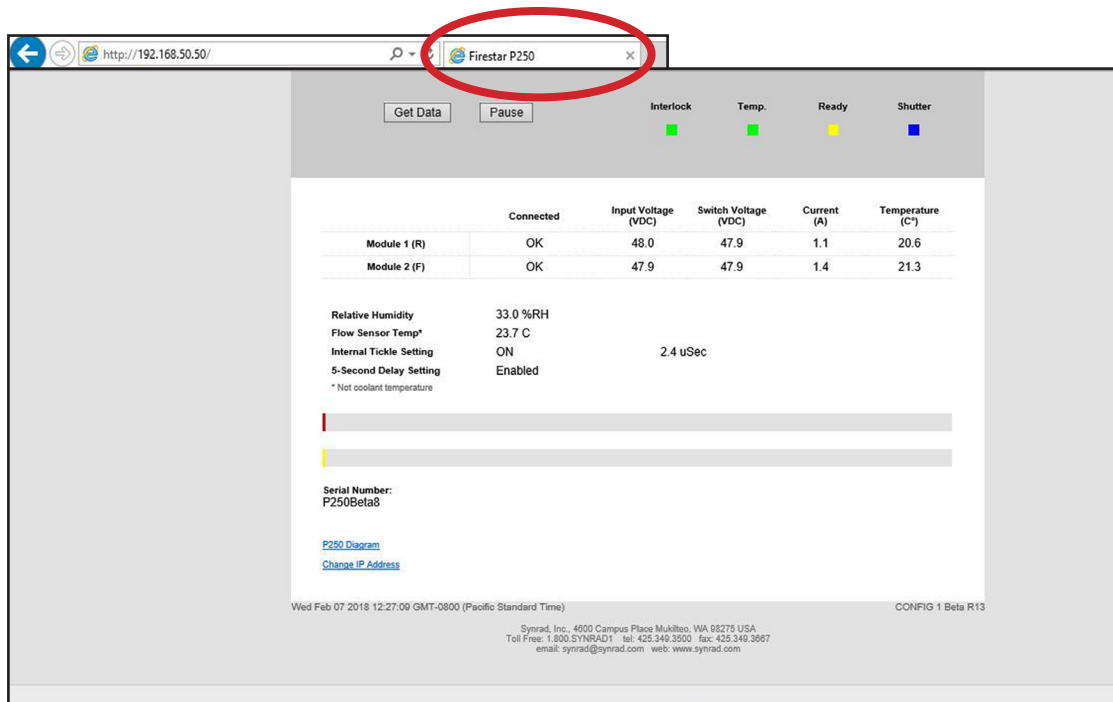

Figure 4-34 Pulstar p250 home page.

When the home page opens, the Pulstar p250 laser begins sending status data based on the laser's current condition. Once the initial data is loaded, the Get Data button becomes active. Click this button to begin updating the static home page once a second. Click the Pause button to halt updating. If a fault should occur while the home page is active, the updating process will automatically halt and an error message is displayed. Displayed data values are accurate to within ± 0.25 units.

Note: On initial power-up of the laser, allow five seconds for the web interface to load before accessing the web page.

1. Get Data button: Click to begin refreshing web page data once a second.
2. Pause button: Click to halt web page updates.
3. Status LEDs: Interlock, Temp, Ready, and Shutter icons display the current state of the laser's Status LEDs.

Technical Reference

Note: Because the p250 home page is a static web page, Ready and Shutter icons will not flash fault codes; however, the gray Error messages section will display the fault.

RF module data

The following operating conditions exist for each of the p250's two RF modules.

Connected

'OK' means that the RF module is connected to the Control module. 'NC' means the Control module does not sense a connection to the RF module.

Input Voltage (VDC)

Displays the DC voltage level measured at the input of the Power module.

Switch Voltage (VDC)

Displays the DC voltage level measured at the input of the RF module.

Current (A)

Displays DC current (Amperage) being drawn by each RF module.

Temperature (°C)

Displays the heat sink temperature of each RF module.

Relative Humidity:

Displays the measured relative humidity (RH) within the p250 laser housing. When purge gas is flowing, the RH value should drop to 0% ($\pm 10\%$) within 10–15 minutes. If the relative humidity never drops below approximately 10%, then slightly increase the purge gas flow rate.

Note: The Flow Sensor Temp value is not a measurement of coolant temperature and should not be used to adjust the chiller's setpoint!

Flow Sensor Temp:

Displays cooling system temperature measured after the RF amplifier modules.

Internal Tickle Setting:

Indicates that tickle is active (ON) and displays the actual tickle setting.

5 Seconds Delay Setting:

Indicates that the five-second delay is active (Enabled).

Technical Reference

Error message area:

Hard faults (those that require a power cycle), are annunciated in the upper (red) error message area while warnings are described in the lower (yellow) message area. If a fault occurs before the web interface is active, the fault or warning message is displayed; however, no other operating data is archived or displayed.

Configure IP Address link:

Click this link to change the laser's factory-default IP address (192.168.50.50). See the Changing the p250's IP address section for details.

Event log page layout

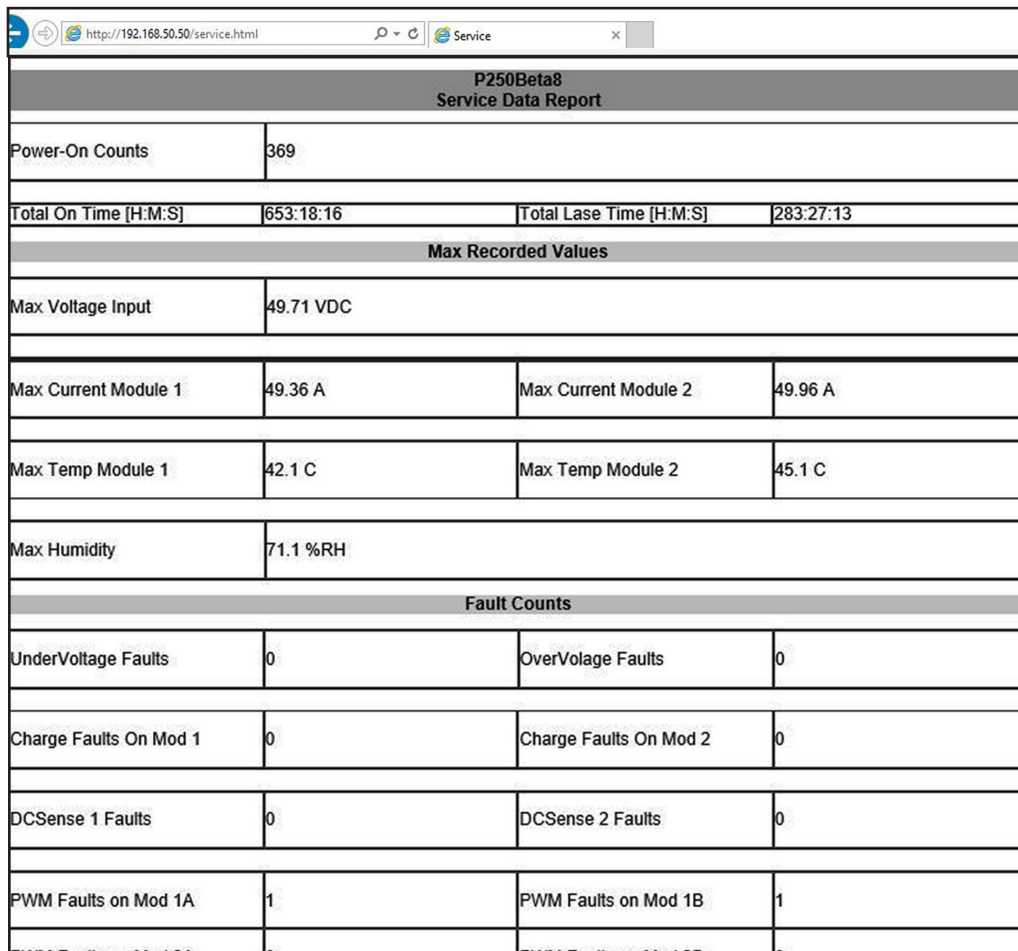

P250Beta8 Service Data Report			
Power-On Counts	369		
Total On Time [H:M:S]	653:18:16	Total Lase Time [H:M:S]	283:27:13
Max Recorded Values			
Max Voltage Input	49.71 VDC		
Max Current Module 1	49.36 A	Max Current Module 2	49.96 A
Max Temp Module 1	42.1 C	Max Temp Module 2	45.1 C
Max Humidity	71.1 %RH		
Fault Counts			
UnderVoltage Faults	0	OverVolage Faults	0
Charge Faults On Mod 1	0	Charge Faults On Mod 2	0
DCSense 1 Faults	0	DCSense 2 Faults	0
PWM Faults on Mod 1A	1	PWM Faults on Mod 1B	1
PWM Faults on Mod 2A	0	PWM Faults on Mod 2B	0

Figure 4-35 Pulstar p250 event log page.

To access the p250's event log page (Figure above), open your web browser, type "http://192.168.50.50/service.html" (without the quotes,) and then press Enter. The event log page opens and displays information recorded over the life of the laser. This information includes power-on cycles as well as total on-time/total lase time; maximum values for voltage, current, temperature, and humidity; and the number of times that various fault conditions have occurred. Refer to the home page for a display of currently active faults, if any exist.

Technical Reference

Changing the p250's IP address

Important Note: !

You must carefully record and store the new IP address for future reference. After the factory-default IP address is changed, it cannot be remotely reset.

To change the p250's factory-default IP address, perform the following steps:

1. From the Pulstar p250 web page, click the Configure IP Address link.
2. The Change IP Address page loads (Figure below), displaying the factory default IP Address, Subnet Mask and Gateway addresses.

Change IP Address							
IPAddress:	192	.	168	.	50	.	50
SubnetMask:	255	.	255	.	255	.	0
Gateway:	192	.	168	.	50	.	1
<input type="button" value="submit"/>							

Figure 4-36 Pulstar p250 Change IP Address page.

3. Change IP Address, Subnet Mask and Gateway addresses as required. Be sure to record these address changes in a safe location and then click the Submit button.

To revert back to the factory default IP settings, simply click Submit when the Change IP Address page opens.

4. Remove DC power from the laser, wait 30 seconds, and then re-apply 48 VDC power.
5. Launch your web browser, type the new IP address (<http://xxx.xxx.xxx.xxx>), and then press Enter. The p250 home page will appear as shown back in previous figure. To reach the event log page, enter "<http://xxx.xxx.xxx.xxx/service.html>" (without the quotes); where xxx.xxx.xxx.xxx is the new IP address.

Alternate Ethernet connection

In situations where it is necessary to isolate the Pulstar p250 laser from your internal IT network, but still access the p250 web page from a networked control computer, you can connect the p250 laser to the networked computer using a USB to Ethernet adapter. Devices like the TRENDnet TU2-ET100 USB to 10/100 Mbps Adapter allow your networked computer to access the Pulstar p250 web page over the computer's USB port, which isolates the laser from your computer network. In this case, use a crossover Ethernet cable between the p250 laser and the USB to Ethernet adapter.

Technical Reference

Pulstar p250 firmware upgrade

- Required materials/equipment
- Firmware upgrade procedure

Required materials/equipment

The following materials and equipment is required to upgrade the firmware in an p250 laser:

- Firmware upgrade file (p250_Firmware_Upgrade.zip) from SYNRAD
- Ethernet crossover cable
- Windows®-based personal computer

Firmware upgrade procedure

Disable your computer's firewall

1. If your computer's firewall is enabled, notify your IT Administrator and disable the fire wall before continuing with this procedure.

Important Note: 

The firmware upgrade must be performed using a peer-to-peer connection between the p250 laser and host computer as described below.

Enable your computer's TFTP Client

1. In the Windows Control Panel, see the prior figure, *double-click Programs and Features*.
2. Once in the Programs and features dialog, *click the 'Turn Windows Features On or Off' Option* as shown in the prior figures.

Note: By default, the TFTP Client is disabled on Windows® 7 and Vista operating systems. Follow the steps in this subsection to enable the TFTP Client feature.

Technical Reference

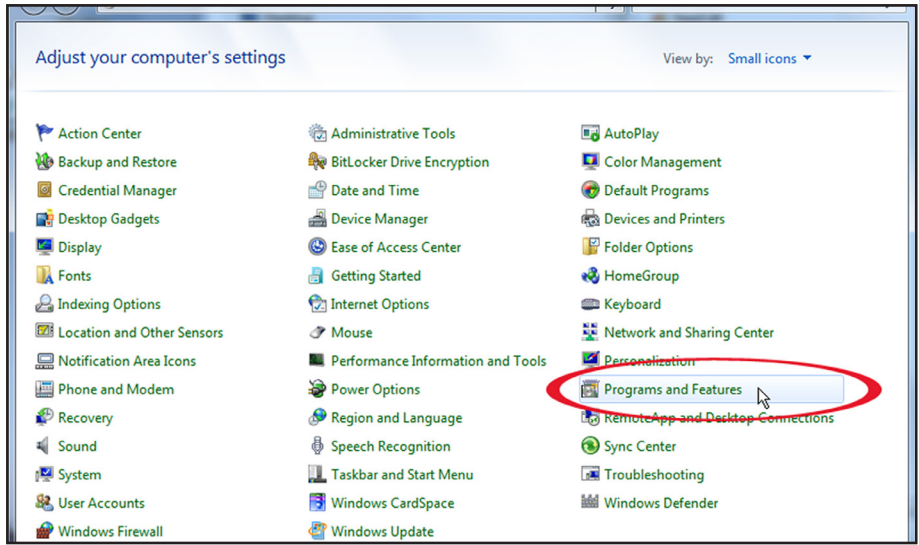

Figure 4-37 Windows Control Panel.

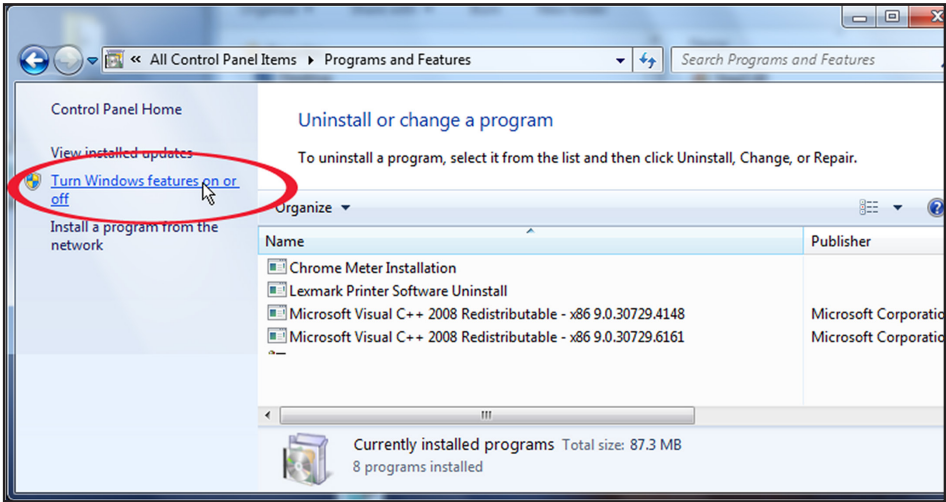

Figure 4-38 Programs and Features dialog.

3. In the Windows Features dialog (Figure below), check "TFTP Client" and then click OK.

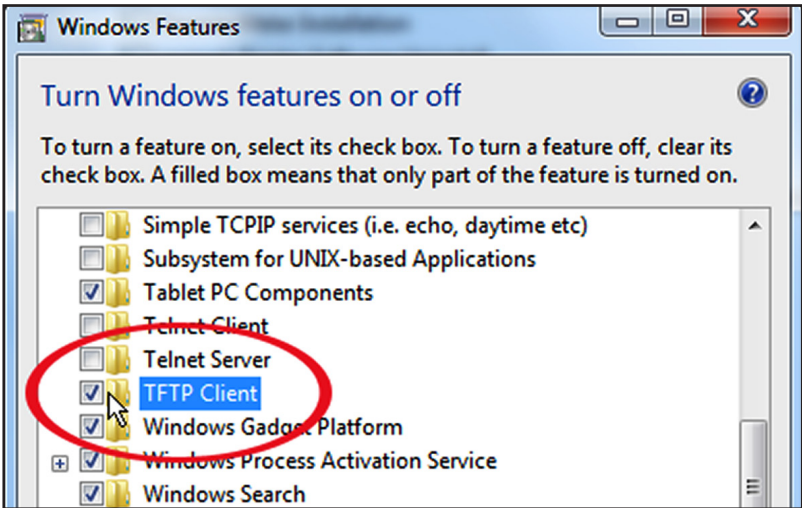

Figure 4-39 Windows Features dialog.

Technical Reference

4. A progress bar window will appear while the TFTP Client feature is being activated. When the window closes, continue with the next section.
5. Restart this computer.

Set your computer's static IP address

Note: The exact steps may vary depending on your operating system.

1. Disconnect the computer from your local network by removing any networking cables.
2. In the Windows Control Panel, *double-click Network and Sharing Center*.
3. In the Network and Sharing Center dialog, *click the Local Area Connection* option.
4. In the Local Area Connection Status dialog, *click the Properties* button.
5. In the Local Area Connection Properties dialog (Figure below), select *Internet Protocol Version 4 (TCP/IPv4)* and *click the Properties* button.

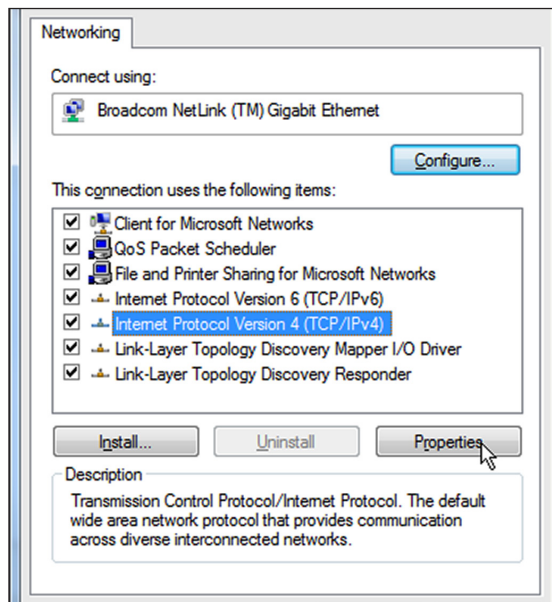

Figure 4-40 Local Area Connection Properties dialog.

6. In the Internet Protocol Version 4 (TCP/IPv4) Properties dialog (see prior figure), select “Use the following IP address:” and enter the following information:

IP Address: 192.168.50.100
Subnet Mask: 255.255.255.0

Note: The Default Gateway field can be left blank.

Technical Reference

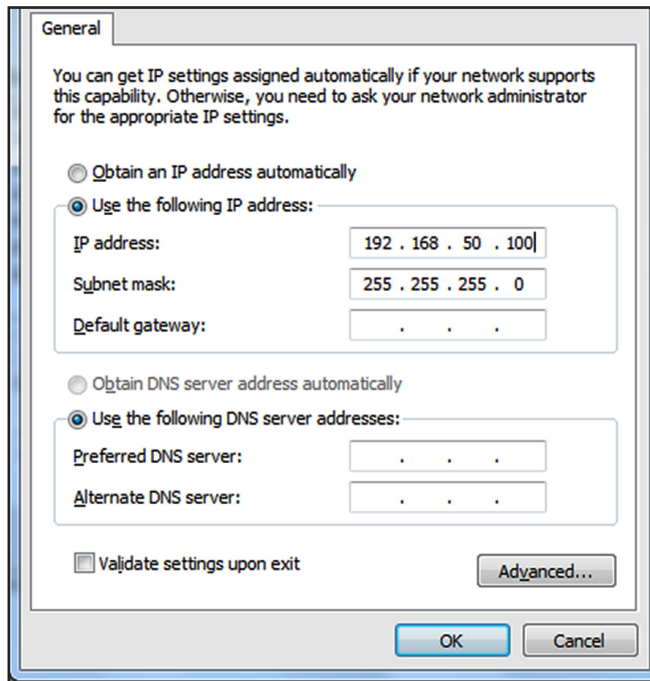

Figure 4-41 Internet Protocol (TCP/IP) Properties dialog.

7. Click *OK* to submit the changes.

Prepare the upgrade files

1. Double-click the *p250_Firmware_Upgrade.zip* file and extract the enclosed firmware upgrade folder to the computer's desktop.
2. Double-click the *firmware upgrade* folder to open it.

Connect to the Pulstar p250 laser

1. Remove DC power from the laser.
2. Locate the Ethernet crossover cable in the ship kit and connect it between your computer and the p250's Ethernet port.
3. Remove the Quick Start Plug from the p250's User I/O connector.
4. Apply 48 VDC power to the laser and wait 15 seconds for the firmware to initialize.
5. If you have changed the p250's IP address (the factory default is 192.168.50.50), you must change it back. If not, proceed to the next section, Perform the firmware upgrade.
 - a. Launch your web browser, type the laser's IP address, and then press Enter.
 - b. When the home page appears as shown in the following figure, click the Configure IP Address link at the bottom of the page.

Technical Reference

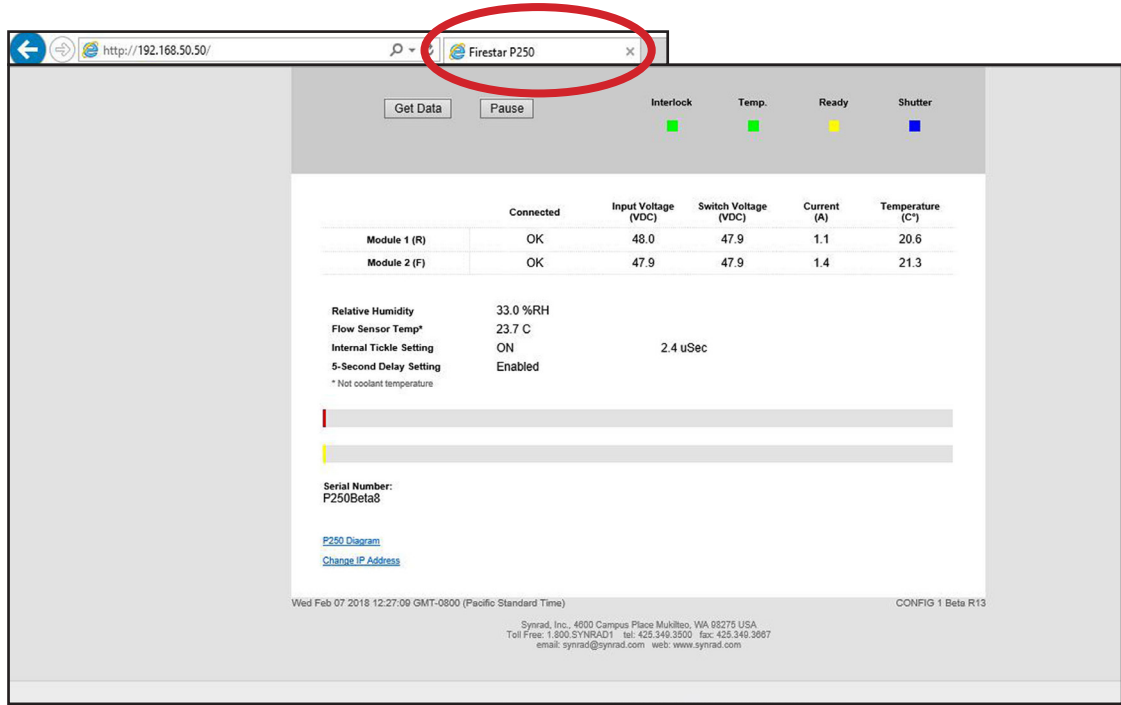

Figure 4-42 Configure IP Address link on Pulstar p250 home page.

- c. When the Change IP Address page loads showing the default IP address (following figure), *click the Submit button*. This resets the laser’s IP address to 192.168.50.50.

Change IP Address

IPAddress: 192 . 168 . 50 . 50
SubnetMask: 255 . 255 . 255 . 0
Gateway: 192 . 168 . 50 . 1

submit

Figure 4-43 Pulstar p250 Change IP Address page.

Perform the firmware upgrade

1. In the firmware upgrade folder, double-click the Update.bat file.
2. Wait until the batch file dialog displays the “Done! Press any key to continue...” message.
3. Press any key to exit the batch file.
4. Remove DC power from the laser, wait 15 seconds, and then re-apply 48 VDC power.
5. Launch your web browser, type: “http://192.168.50.50” (without the quote symbols) and then press Enter.
6. When the p250 Home page appears (following figure), check the label on the web browser’s tab. It should read: Pulstar p250: CONFIG 2 – X.X to indicate the laser is running upgraded firmware.

Technical Reference

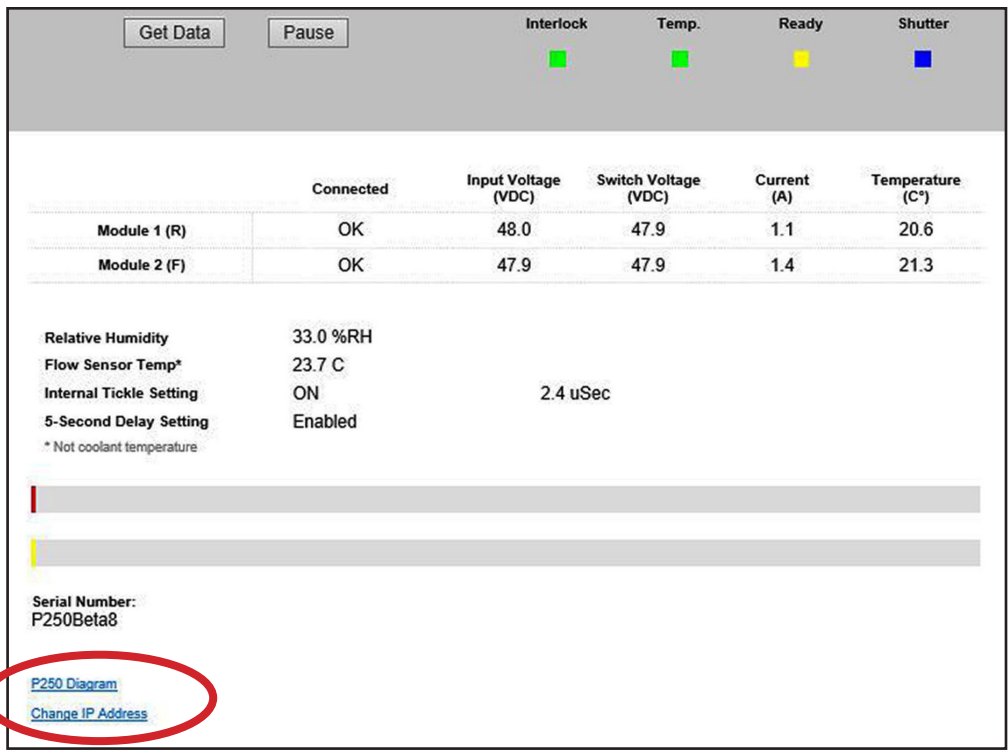

Figure 4-44 Pulstar p250 web browser display.

7. If necessary, *click the Configure IP Address link* at the bottom of the p250 web page and reset the default IP address to the specific address required for your application.

Re-enable your computer's firewall

1. If your computer's firewall was disabled for this procedure, notify your IT Administrator and re-enable the firewall.

Integrating Pulstar safety features

- Keyswitch functions
- Shutter functions
- Remote interlock functions

Pulstar's DB-15 User I/O connector allows system integrators or end-users to integrate Pulstar safety features into their control system. Pulstar's key-switch, shutter, and remote interlock functions serve to enable or disable DC power to Pulstar's RF drive. Without DC power, the RF driver cannot supply RF energy to the resonator, causing the CO₂ gas to remain in a zero-energy state. Pulstar status indicators provide users with a quick visual indication of the laser's operational status. All power to the laser's RF board is removed when the RDY indicator is Off (Laser Ready output open).

Key-switch functions OEM lasers

On OEM lasers, the RDY LED illuminates on DC power-up (when the Remote Interlock input is enabled) and five seconds later, DC power is applied to the RF driver. When the Shutter Open Request input is inactive (SHT indicator Off) only tickle pulses are applied to the laser. PWM Command signals are enabled only when voltage is applied to both Shutter Open Request and Remote Interlock inputs (INT LED green, RDY LED On, and SHT LED On). Over temperature faults are reset by removing and then re-applying DC power after the laser has cooled. Remote interlock faults are not latched; the RDY LED illuminates yellow as soon as the interlock circuit is closed (when the INT LED turns from red to green) and five seconds later lasing is enabled.

Although a Remote Reset/Start Request input is not required to reset OEM faults, it can be used to inhibit (disable) lasing. Disable the laser by applying a voltage in the range of $\pm 5-24$ VDC to Pin 2, the Remote Reset/Start Request input. Removing voltage allows power to reach the RF driver and begins a five-second countdown after which lasing is enabled (RDY LED illuminates yellow). The RF driver is disabled as long as voltage is applied to Pin 2.

Note: When connecting field wiring to the Remote Reset/Start Request input, use twisted pair and/or shielded cabling. Refer to SYNRAD Technical Bulletin #021 for details. After the Laser Ready output closes, a five-second delay occurs before lasing is enabled.

Your control system can monitor the laser's ready status on the User I/O connector by connecting your system's input between Pin 8, Laser Ready, and Pin 13, Output Common (see prior figures).

The Laser Ready output closes when the laser is enabled (RDY LED illuminated yellow), indicating that lasing is possible. The output is open (RDY LED off) when lasing is disabled.

Shutter functions

An internal EM shutter is optional for p250 lasers, but the electronic shutter is available on all lasers. Lasing is enabled when the shutter is open (SHT LED illuminated blue) and disabled when the shutter is Closed (SHT LED off).

For p250 OEM lasers in automated systems, shutter actuation is provided by the (EM) Shutter Open Request signal via Pin 10 on the User I/O connector. To use this feature, apply a voltage in the range of ± 5 –24 VDC to Pin 10, Shutter Open Request. This input signal causes the SHT LED to illuminate (provided the RDY indicator is On) and opens the physical shutter to allow lasing. Removing voltage from the Shutter Open Request input causes the physical shutter to close and block the beam path, extinguishing the SHT lamp and allowing only tickle signals to reach the tube.

Your control system can monitor the laser's shutter status on the User I/O connector by connecting your system's input to Pin 14, Shutter Open, and Pin 13, Output Common (see Output Signal section and Figures above). The Shutter Open output closes when a Shutter Open Request signal is present (SHT LED illuminated blue) and the Laser Ready output is closed (RDY LED is On). The output is open (SHT LED Off) when the Shutter Open Request signal is removed or the Laser Ready output is open (RDY LED is Off).

Remote interlock functions

Interlock circuits are often used to disable machinery when a shield, panel, or door is opened. Pulstar's remote interlock function allows you to connect into an external remote interlock circuit and prevent lasing by removing DC power from the laser's RF driver boards when the circuit is electrically "open".

Lasing is enabled when a Remote Interlock signal is present (INT LED illuminated green), if the RDY LED is illuminated and a Shutter Open Request signal is applied. Lasing is disabled when the Remote Interlock signal is removed (INT LED red, RDY LED off). DC power is applied to the RF driver only when the INT LED is green and the RDY LED is yellow. Remote interlock functionality is provided by the Remote Interlock signal via Pin 3 on the User I/O connector.

To use Pulstar's remote interlock feature to initiate lasing, apply a voltage in the range of ± 5 –24 VDC to Pin 3, Remote Interlock. Applying a Remote Interlock signal causes the INT LED to turn green, the RDY indicator to turn yellow, and sends DC power to the laser's RF boards. After a five-second delay, a tickle signal is applied to the tube. When a Shutter Open Request signal is present, PWM Command signals are enabled to begin lasing. Removing voltage stops DC power from reaching the RF driver, causing the INT LED to turn red and the RDY LED to turn Off. Lasing remains disabled until a voltage is reapplied to Pin 3.

Your control system can monitor the laser's remote interlock status on the User I/O connector by connecting your system's input to Pin 15, Interlock Open, and Pin 13, Output Common (see Figures above). This output is closed when remote interlock circuitry is open (INT LED illuminated red). The output is open (INT LED green) when interlock circuitry is closed.

Technical Reference

Pulstar p250 General Specifications

Table 4-5 Pulstar p250 general specifications.

Parameter	p250 (10.2 μm)	p250 (10.6 μm)
Output Specifications		
Wavelength typical	10.2 μm	10.6 μm
Average Power Output (minimum) ²	>250 W	
Peak Power, typ ¹	750 W	800 W
Peak Pulse Energy, (maximum)	600 mJ Tested at 625Hz, 37.5% Duty Cycle	
Power Stability, from cold start	$\pm 5\%$	
Power Stability, typical after 3 min.	$\pm 3\%$	
Mode Quality	$M^2 \leq 1.2$	
Beam Waist Diameter at face-plate (at $1/e^2$)	8.0 mm \pm 1.0 mm	9.0 mm \pm 1.0 mm
Beam Divergence, full angle (at $1/e^2$)	1.9 mrad \pm 0.4 mrad	
Ellipticity	< 1.2	
Polarization	Linear, horizontal	
Rise and Fall Time ¹	<60 μs ^(Rise) < 110 μs ^(Fall) Tested at 1kHz, 10% Duty Cycle	
Input Specifications		
Power Supply		
Input Voltage / Current	48 VDC \pm 0.5 / 90 A	
Peak Current	250 A for \leq 1ms	
Command Input Signal		
Voltage	+3.5 to +6.7 VDC (5V nominal)	
Current	10 mA @ +6.7 VDC	
Frequency Range	Single shot to 100 kHz	
Duty Cycle Range ¹	0-45%	
Pulse Length, max	1000 μs	
Logic Low State (Vmin–Vmax)	0.0 to +0.8 VDC	
Logic High State (Vmin–Vmax)	3.5 to 6.7 VDC	

Technical Reference

Table 4-5 Pulstar p250 general specifications (Continued).

Parameter	p250 (10.2 μm)	p250 (10.6 μm)
Environmental Specifications		
Operating Temperature	15 °C–40 °C	
Humidity	0-95%, non-condensing	
Cooling Specifications		
Maximum Heat Load, laser	4.3 kW	
Flow Rate	3.0 GPM at < 60 PSI (11.4 LPM at < 414 kPa)	
Maximum Coolant Pressure	60 PSI	
Pressure Drop	8 PSI @ 3 GPM (55 kPa @ 11.4 LPM)	
Coolant Temperature ³	18–22 °C	
Coolant Temperature Stability ⁴	± 1.0 °C	
Environmental Specifications		
Length	49.3 in (125.2 cm)	
Width	12.4 in (31.5 cm)	
Height	7.8 in (19.8 cm)	
Weight	107.0 lb (48.5 kg)	
<p>* Specifications subject to change without notice. Measurements performed at 5 kHz, 37.5% duty cycle unless otherwise noted.</p> <p>1 Measured at 1kHz, 10% Duty Cycle.</p> <p>2 Power level guaranteed for 24 months from date of shipment, regardless of hours, provided laser is operated within the recommended coolant flow-rate and operating temperature range.</p> <p>3 At coolant temperatures above 22 °C, derate power 0.5 W/°C to 1 W/°C up to a coolant temperature of 28 °C.</p> <p>4 See cooling section for the graph of pressure drop versus flow rate.</p>		

Technical Reference

Pulstar p250 Outline & Mounting Drawings

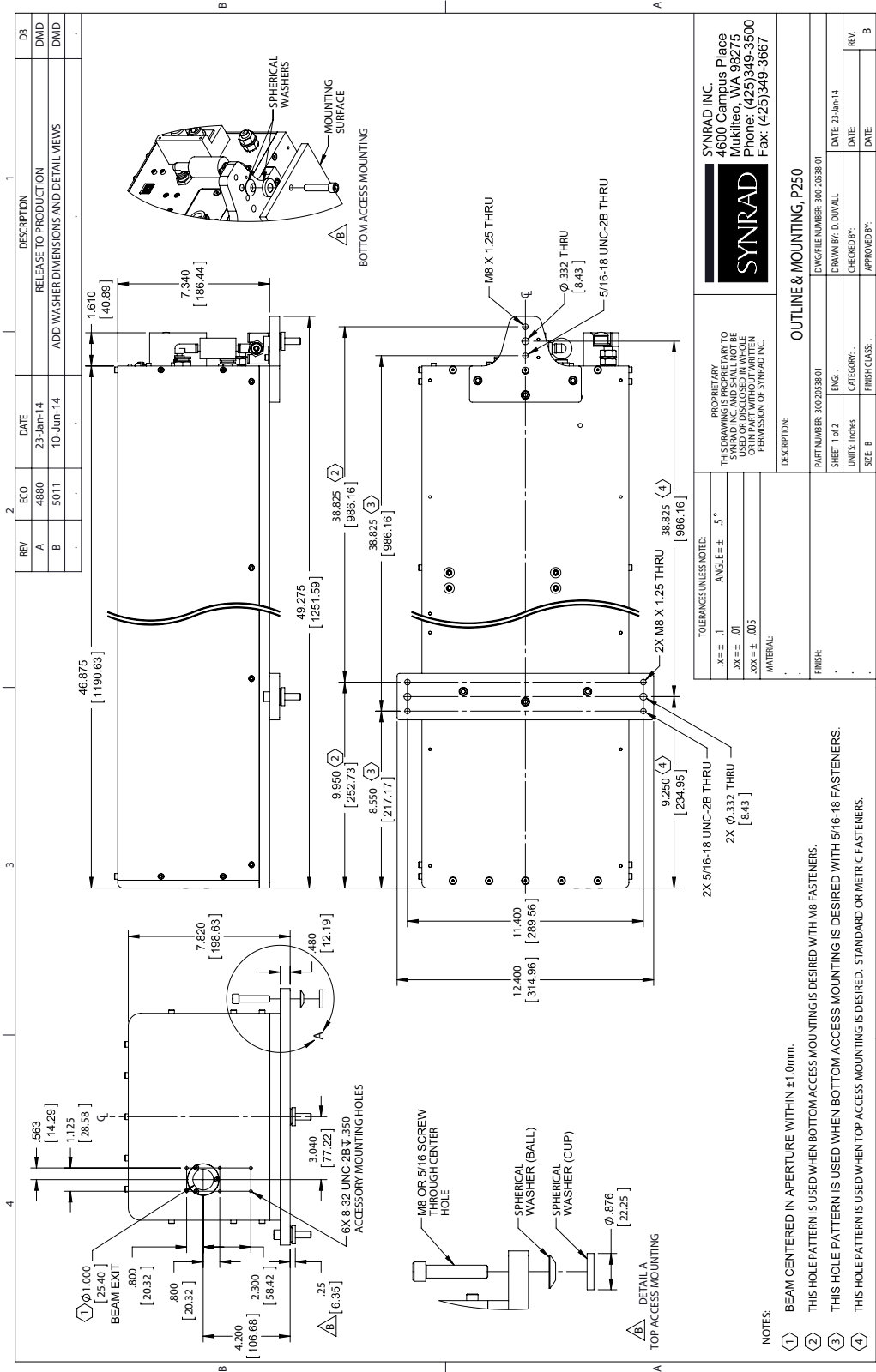

Figure 4-45 Pulstar p250 outline & mounting dimensions.

Technical Reference

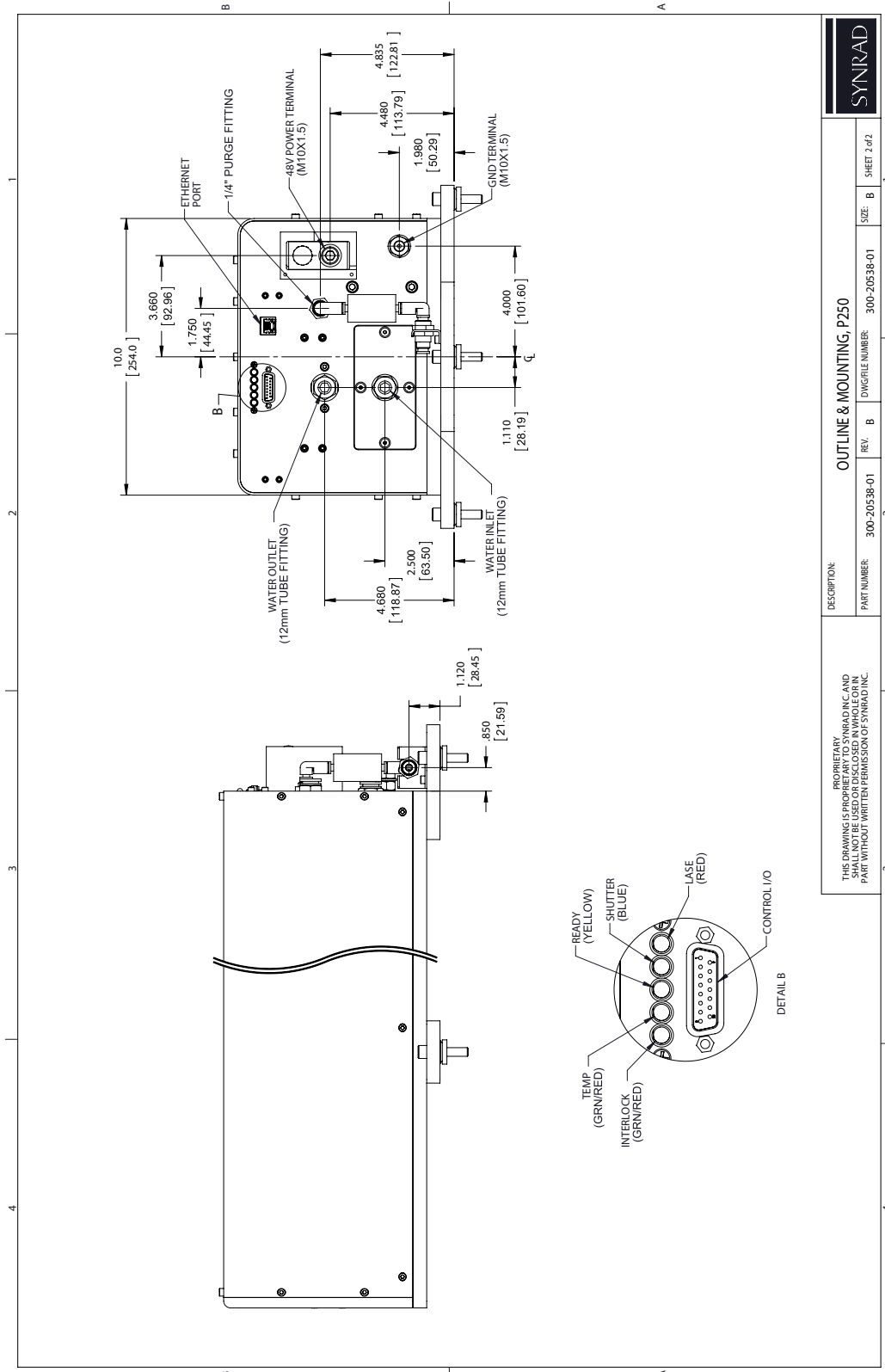

Figure 4-46 Pulstar p250 outline & mounting dimensions (mounting feet removed).

Technical Reference

REV	ECO	DATE	DESCRIPTION	DB
A	4925	19-Mar-14	RELEASE TO PRODUCTION	DMD

PACKAGING INSTRUCTIONS:

1. LIFT LASER SLING OUT OF SHIPPING CONTAINER AND PLACE ON SOLID SURFACE.
2. PLACE LASER INSIDE FOAM CAVITIES ON LASER SLING, MAKING SURE FRONT OF LASER IS ON LEFT SIDE.
3. USE TWO OR MORE PEOPLE TO LIFT LASER/LASER SLING AND PLACE INTO BOTTOM SHIPPING CONTAINER. COVER WITH TOP SHIPPING CONTAINER AND SECURE AS REQUIRED. NOTE: TOP SHIPPING CONTAINER CONTAINS FOAM CAVITIES, ORIENT FOR PROPER FIT. WRITESYNRAD RETURN AUTHORIZATION NUMBER ON OUTSIDE OF SHIPPING BOX.
- 4.
- 5.

IMPORTANT NOTE: FAILURE TO PROPERLY PACKAGE LASER USING SYNRAD SHIPPING BOX AND FOAM/CARDBOARD INSERTS AS SHOWN MAY VOID WARRANTY. CUSTOMERS MAY INCUR ADDITIONAL REPAIR CHARGES DUE TO SHIPPING DAMAGE CAUSED BY IMPROPER PACKAGING.

<p>TOLERANCES UNLESS NOTED:</p> <p>.x = ± .1 ANGLE = ± .5°</p> <p>.xx = ± .01</p> <p>.xxx = ± .005</p> <p>MATERIAL: SEE BOM</p>	<p>PROPRIETARY THIS DRAWING IS PROPRIETARY TO SYNRAD INC. AND SHALL NOT BE USED OR DISCLOSED IN WHOLE OR IN PART WITHOUT WRITTEN PERMISSION OF SYNRAD INC.</p>	<p style="text-align: center;">SYNRAD</p> <p style="text-align: center;">SYNRAD INC. 4600 Campus Place Mukiteo, WA 98275 Phone: (425)349-3500 Fax: (425)349-3667</p>
DESCRIPTION: DOC, INSTRUCTION, PACKAGING, P250		
PART NUMBER: 900-20538-01		
SHEET 1 of 1	ENG: .	DATE: 19-Mar-14
UNITS: Inches	CATEGORY: I	DATE: .
SIZE: A	FINISH CLASS: .	DATE: .

Figure 4-47 Pulstar p250 packaging instructions.

Maintenance/ Troubleshooting

5

Chapter Introduction

This chapter contains maintenance and troubleshooting information for your Pulstar p250 laser.

- Maintenance – describes typical Pulstar p250 maintenance procedures.
- Troubleshooting – explains how to troubleshoot common Pulstar p250 problems.

Important Note:



This section of the Operation Manual explains how to conduct regular maintenance and/or basic troubleshooting to Pulstar p250 lasers. If you cannot attend to the unit using the information described in this manual, contact SYNRAD, (+.425.349.3500) or an authorized SYNRAD Distributor.

Caution
Possible
Equipment
Damage



Inlet cooling water temperature must always be maintained above the dew point to prevent condensation and water damage to your Pulstar laser.

-Or-

Use purge gas to prevent condensation damage if the dew point is over 22°C

Do not exceed a gas purge pressure of 34.5 kPa (5 PSI). Excessive pressure may damage the purge assembly or other internal laser components.

Do not use argon as a purge gas. Use only nitrogen or clean, dry air as described in the in this chapter.

Maintenance/ Troubleshooting

Maintenance

- Disabling the p250 laser
- Daily inspections
- Storage/shipping
- Cleaning optical components

Disabling the p250 laser

Before performing any maintenance on your Pulstar p250 laser, be sure to completely disable the laser by disconnecting the DC Power Cables from the DC power supply.

Daily inspections

Perform the following steps daily to keep your Pulstar p250 laser in optimum operating condition. Except for the procedures described below, no other service is required or should be attempted.

Caution **Possible** **Equipment** **Damage**



If you operate the laser in dirty or dusty environments, contact SYNRAD about the risks of doing so and precautions you can take to increase the longevity for the laser system and associated optical components.

1. Inspect all cooling tubing connections for signs of leakage. Check for signs of condensation that may indicate the cooling water temperature has been set below the dew point temperature. Condensation will damage electrical and optical components inside the laser. See the Setting coolant temperature section in the Technical Reference chapter for details on preventing condensation.
2. When using compressed air as a purge gas on your p250 laser, empty water traps and oil separators on each filter and/or dryer between the laser and your compressed air source. Compressed air purity must meet the purge gas specifications within this Operators Manual.
3. Inspect beam delivery components for signs of dust or debris and clean as required. When cleaning the optical surfaces of beam delivery components, carefully follow the manufacturer's instructions.
4. Visually inspect the exterior housing of the laser to ensure that all warning labels are present. Refer to the Laser Safety chapter for p250 label types and locations.

Maintenance/ Troubleshooting

Storage/shipping

When preparing the laser for storage or shipping, remember to drain cooling water from the laser. In cold climates, any water left in the cooling system may freeze, which could damage internal components. After draining thoroughly, use compressed shop air at no more than 200 kPa (29 PSI)—Wear safety glasses!—to remove any residual water. When finished, cap all connectors to prevent debris from entering the cooling system.

When shipping SYNRAD lasers to another facility, we highly recommend that you ship the unit in its original SYNRAD shipping container. If you no longer have the original shipping box and inserts, contact SYNRAD Customer Service about purchasing replacement packaging. Refer to Packaging instructions in the Technical Reference chapter for detailed instructions on properly packaging the laser for shipment.

Cleaning optical components

Debris or contaminants on external beam delivery components may affect laser processing and lead to damage or failure of the optics and/or the laser. Carefully follow the steps below to inspect and clean the optical components in the beam path. Before beginning the cleaning process, read this entire section thoroughly to ensure that all cleaning materials are available and that each step is completely understood.

Caution Possible Equipment Damage



Even small amounts of contamination on optics in the beam path can absorb enough energy to damage the optic. Inspect beam delivery optics periodically for signs of contaminants and carefully clean as required. In dirty environments, purge laser optics using filtered air or nitrogen to prevent vapor and debris from accumulating on optical surfaces.

Important – Pulstar p250 lasers have several beam conditioning optics between the output aperture and the faceplate. To prevent dust and debris from damaging these optical surfaces, always connect nitrogen or filtered air to the laser's Gas Purge port.

Important Note:



Failure to properly package the laser using SYNRAD-supplied shipping boxes and foam/cardboard inserts as shown in the Packaging instructions may void the warranty. Customers may incur additional repair charges for shipping damage caused by improper packaging.

Warning Serious personal injury



Ensure that DC power to the laser is turned off and locked out before inspecting optical components in the beam path.

Invisible CO₂ laser radiation is emitted through the aperture. Corneal damage or blindness may result from exposure to laser radiation.

Maintenance/ Troubleshooting

Cleaning guidelines

- Wear latex gloves or finger cots (powder-free) to prevent contamination of optical surfaces by dirt and skin oils.
- Never handle optics with tools; always use gloved hands or fingers.
- Hold optics by the outer edge; never touch the coated surface.

Important Note:  Exercise great care when handling infrared optics; they are much more fragile than common glass materials. Optical surfaces and coatings are easily damaged by rough handling and improper cleaning methods.

- Always place optics lens on a tissue or suitable equivalent material for protection; never place optics on hard or rough surfaces.
- It may be necessary to use a cotton ball or fluffed cotton swab instead of a lens wipe to uniformly clean the entire surface of small-diameter mounted optics.
- Before using any cleaning agents, read Safety Data Sheets (SDS) and observe all necessary safety precautions.

Required cleaning materials

The table below lists the type and grade of materials required to properly clean optical surfaces.

Table 5.1 Required cleaning materials.

Cleaning Material	Requirements
Latex gloves or finger cots	Powder-free
Air bulb	Clean air bulb
Ethyl or isopropyl alcohol	Spectroscopic or reagent grade
Acetone	Spectroscopic or reagent grade
Lens wipe (preferred)	Optical (clean-room) quality
Cotton balls or cotton swabs	High-quality surgical cotton/high-quality paper-bodied

Cleaning optics

1. Shut off and lock out all power to the laser. You must verify that the laser is OFF (in a zero-energy state) before continuing with the optical inspection!
2. Visually inspect all optical surfaces in the beam path for contaminants.
3. Remove loose contaminants from the optic by holding a clean air bulb at an angle to the optic and blow a stream of air at a glancing angle across the lens surface. Repeat as necessary.

Maintenance/ Troubleshooting

Caution Possible Equipment Damage



Do not allow the nozzle of the air bulb to touch the optical surface. Any contact may damage the optic by scratching coatings on the optical surface.

Do not use compressed shop air to blow contamination from the optic. Compressed air contains significant amounts of water and oil that form adsorbing films on the optical surface.

Do not exert pressure on the surface of the optic during cleaning. Optical surfaces and coatings are easily scratched by dislodged contaminants.

Use a new lens wipe on each pass as contaminants picked up by the wipe may scratch the optical surface.

4. Dampen a lens wipe with the selected cleaning agent. Alcohol (least aggressive) is best for initial surface cleaning. Acetone (moderately aggressive) is best for oily residue or minor baked-on vapors and debris.
5. Gently, and without applying pressure, drag the damp lens wipe across the optical surface in a single pass. Do not rub or apply any pressure, especially when using a cotton swab. Drag the wipe without applying any downward pressure. Use a clean lens wipe on each pass. The wipe will pick up and carry surface contaminants that may scratch optical surfaces or coatings.
6. Carefully examine the optic under suitable lighting. Certain contaminants or damage such as pitting cannot be removed. In these cases the optic must be replaced to prevent catastrophic failure.
7. Repeat Steps 4 through 6 as required, removing all traces of contaminants and deposits.

Caution Possible Equipment Damage



If acetone is used as a cleaning solvent, a second follow-up cleaning of the optical surface using alcohol is required. Otherwise solvent residuals could damage your laser!

Note: To prevent streaking during the final alcohol cleaning, drag the lens wipe slowly across the surface so that the cleaning liquid evaporates right behind the wipe.

Maintenance/ Troubleshooting

Troubleshooting

- Operational flowchart
- Functional block diagram
- Status LEDs
- Laser fault indications

The Troubleshooting section is designed to help isolate problems to the module level only. Problems on circuit boards or the laser tube are outside the scope of this guide because they are not user-serviceable assemblies; do not attempt to repair them. Contact SYNRAD or a SYNRAD Authorized Distributor for repair information.

To troubleshoot Pulstar p250 lasers, it is necessary to understand the sequence of events that must happen before the laser can operate. Before attempting any service, we advise you to read the entire troubleshooting guide and review both the operational flowchart and the functional block diagram.

Caution

Possible Equipment Damage



Attempting repair of a SYNRAD Pulstar laser without the express authorization of SYNRAD, will void the product warranty.

If troubleshooting or service assistance is required, please contact SYNRAD Customer Service.

Maintenance/ Troubleshooting

Operational flowchart

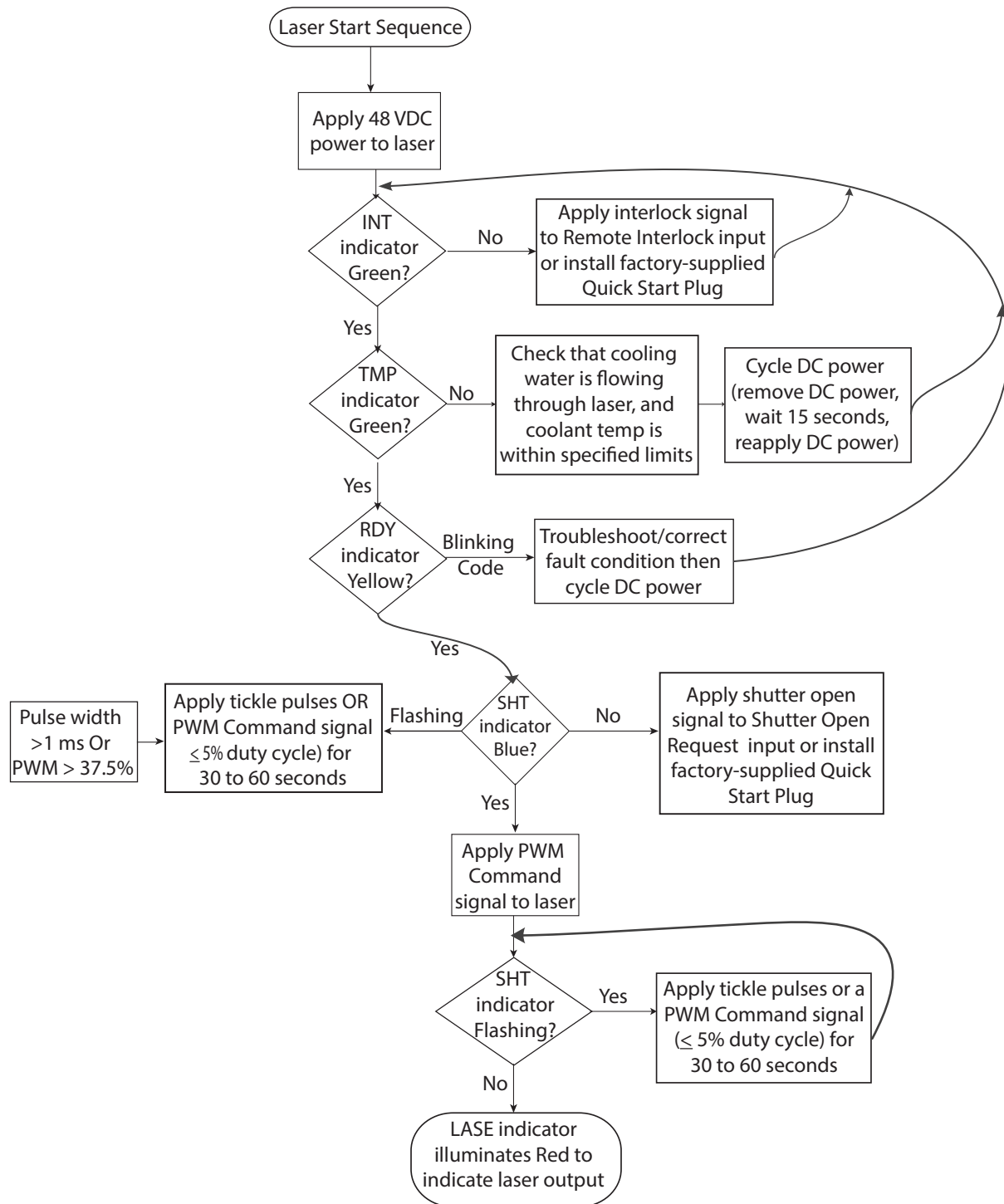

Figure 5-1 Pulstar p250 operational flowchart.

Maintenance/ Troubleshooting

Status LED's

LASER CONDITION / FAULT	INPUT STATUS				LED STATUS					OUTPUT STATUS					COMMENTS
	Remote Interlock	Remote Reset / Start Request	Shutter Open Request	PWM	INT	TMP	RDY	SHT	LASE	Interlock Open	Fault Detected	Laser Ready	Shutter Open	Laser Active	
DC Power Off	x	x	x	x	○	○	○	○	○						No RF to tube
DC Power Applied, Laser Disabled	0	x	x	x	●	○	○	○	○	C					No RF to tube
	x	1	x	x	○	○	○	○	○						Tickle applied to tube for 5 seconds, then laser may fire
DC Power Applied, Laser Enabled	1	0	1	0	●	●	●	●	○		C	C	C	C	Normal laser operation
Laser Firing	1	0	1		●	●	●	●	●	C					No RF to tube
Interlock Open	0	0	1	x	●	○	○	○	○		C				Cooling problem
Over Temperature	1	0	1	x	●	●	○	○	○		C				No RF to tube
Electromechanical Shutter Not Open	1	0	1	x	●	●	○	○	○			C			Voltage below 46VDC
Under Voltage	1	x	1	x	●	○	⊗ ¹	○	○				C		Voltage over 50VDC
Over Voltage	1	x	1	x	●	○	⊗ ²	○	○				C		Laser service required
RF Drive Switch Fault	1	x	1	x	●	○	⊗ ³	○	○				C		Laser service required
PWM Drive Fault	1	x	1	x	●	○	⊗ ⁴	○	○				C		Laser service required
DC Pre-Charge Fault	1	x	1	x	●	○	⊗ ⁵	○	○				C		>95% Relative Humidity inside laser chassis
Internal Humidity; Laser Quits Lasing	1	0	1	x	●	○	○	○	○						Output limited to 5%
No Strike Fault	1	0	1	x	●	○	○	⊗ ⁶	○		C	C	C	C	Lower PWM frequency below 100kHz to clear fault
Frequency Limit Condition	1	0	1	x	●	○	○	○	○		C				Lower Duty Cycle below 45% or Pulse Width below 1ms
Duty Cycle / Pulse Width Limit Condition	1	0	1	x	●	○	○	⊗ ³	○		C				

TABLE KEY:	
○ = Input OFF	⊗ = Blinking LED; number represents blink sequence
● = Input ON	⊗ = Blinking LED; "C" represents continuous blinking sequence
x = Does not matter	

Table 5.2 p250 Input/Output & LED Status Signals.

Maintenance/ Troubleshooting

Troubleshooting Status LED's

Pulstar p250 LED indicators, also mirrored as output signals on the User I/O connector, provide status information to the user. The prior table shows Pulstar input/output signal and LED indicator states during normal and fault conditions. User I/O outputs are Closed when the state indicated by the signal name is logically True.

On DC power-up, the RDY lamp illuminates yellow when INT and TMP indicators illuminate green. After the RDY indicator illuminates an internal tickle is enabled. There is a five-second delay before lasing is permitted. When a Shutter Open Request signal is applied; the internal shutter opens, the SHT LED illuminates blue, and application of a PWM Command signal causes the LASE indicator to illuminate red as lasing begins.

For safety reasons, the shutter function on p250 lasers is dependent on the state of the Remote Interlock input. The Remote Interlock Input status is reflected by the state of INT and RDY indicators. Although a Shutter Open Request signal may be applied, the SHT LED will not illuminate while the INT LED is red (RDY LED Off). Therefore, no power is applied to the RF boards until the INT indicator is green (and the RDY LED is yellow).

The following section illustrates the dependencies of various operating parameters based on the state of the Remote Interlock input. The conditions shown in bold are those required for lasing to be enabled.

Possible Causes:

- No voltage is applied to Pin 3 (Remote Interlock) of the User I/O connector.

On systems using remote interlocks, check to see that a positive or negative voltage in the range of 24 ± 5 VDC is applied to Pin 15. For remote Interlocks, with respect to Pin 11 and Input Common on the User I/O Connector please refer to User I/O connections in the Technical Reference chapter for details. For systems not using interlocks, wire a male DB-15 connector to the User I/O connector so that Pin 11 (Input Common) is jumpered to Pin 12 (Auxiliary DC Power Ground) and Pin 15 (Remote Interlock) is jumpered to Pin 4 (+5 VDC Auxiliary Power).

On DC power-up of a p250 laser, the RDY lamp illuminates yellow provided INT and TMP indicators illuminate green. Once the RDY indicator illuminates yellow, an internal tickle is enabled and after a five-second period lasing is then permitted. When the Shutter Open Request signal is applied, the internal (EM) shutter opens, the SHT LED illuminates blue, and an application of a PWM Command signal causes the LASE indicator to illuminate red as lasing begins.

Remote interlock condition

A remote interlock condition occurs when the Remote Interlock input opens. The INT LED is red and the Interlock is closed. The (EM) internal shutter mechanism closes and lasing is halted immediately. On OEM p250 lasers, a remote interlock condition is not latched. Re-apply the Remote Interlock signal by reapplying input voltage to that pin and enabling the INT LED to change from red to green. The the interlock (shutter) opens to enable the RDY indicator. Lasing can begin after the five-second delay provided the SHT indicator is illuminated blue and a PWM Command signal is applied.

Maintenance/ Troubleshooting

Troubleshooting Status LED's

Possible Causes:

- No voltage is applied to Pin 14 (Shutter open) of the User I/O connector.

Verify 24 ± 5 VDC is applied to Pin 14 (Shutter Open Request). For Pin 15 Input Common on the User I/O Connector please refer to the User I/O connections section in the Technical Reference chapter for details. If your system does not provide a Shutter Open Request signal, wire a male DB-15 connector to the User I/O connector so that Pin 15 (Input Common) is jumpered to Pin 12 (Auxiliary DC Power Ground) and Pin 14 (Shutter Open Request) is jumpered to Pin 4 (+5 VDC Auxiliary Power).

When a Shutter Open Request signal is applied to the laser, PWM Command signals are inhibited until the shutter is fully open. It takes approximately 30 ms for the EM shutter to fully open. When the Shutter Open Request signal is removed from Pin 10, PWM Command signals are inhibited immediately even though it takes approximately 120 ms for the EM shutter to fully close. Tickle pulses signals continue to be applied to the RF modules during the close/open EM shutter interval.

Possible Causes:

- The (Optional) Quick Start Plug or Remote Interlock/Shutter Open Request inputs are not connected to the User I/O connector.

Connect the Quick Start Plug or interlock/shutter input field wiring to the DB-15 User I/O connector. See User I/O connections in the Technical Reference chapter for wiring details.

Laser fault indications

Pulstar p250 lasers have the ability to indicate eight specific fault conditions. In the event of certain faults, the RDY LED will blink an error code, pause four seconds, and then repeat the error code. This sequence continues until the fault is corrected and the laser is reset by cycling DC power to the laser. If a No-Strike condition occurs, the SHT LED flashes continuously until the gas breaks down into a plasma state.

Refer to the table above for a status list, the corresponding fault, and description in the comments for basic corrective action. See the Resetting faults section for detailed corrective actions.

Warning **Serious** **personal** **injury**



On Pulstar p250 OEM lasers, *remote interlock faults are not latched*. Clearing the fault condition re-enables the RDY indicator and the laser will fire after the five-second delay provided the SHT indicator is lit and a PWM Command signal is applied. Because exposure to CO₂ laser radiation in 9.3–10.6 μm wavelength band can inflict severe corneal injuries and seriously burn human tissue, the OEM or System Integrator must ensure that appropriate safeguards are in place to prevent unintended lasing.

Maintenance/ Troubleshooting

Troubleshooting Status LED's

Possible Causes:

- Coolant temperature is above 28 °C (82 °F) or there is inadequate coolant flow through the laser. Check that your chiller is maintaining a water temperature between 18 °C–28 °C (64 °F–82 °F) at a flow rate of 15.1 liters per minute (4.0 GPM).

Note: OEM lasers can be operated at coolant temperatures up to 28 °C (64 °F to 82 °F) at a flow rate of 11.4 liters per minute (3.0 GPM).

If water temperature is OK, check the flow rate. If a flow meter is not available, disconnect the cooling tubing from the chiller inlet (or the drain) and run the cooling water for 30 seconds into a five-gallon bucket. After 30 seconds, a minimum of 1.5 gallons or (5.8 L) should be collected. If there is less than 1.5 gallons or (5.8 L), check the cooling path for kinked or pinched cooling tubes or check the chiller for a clogged or dirty filter.

On p250 lasers, the over-temperature fault is indicated by a red TMP indicator (latched status). If an over-temperature condition occurs, the TMP indicator will turn red, the Fault Detected output will latch, and the RDY indicator light will turn off. Lasing will become disabled. Due to the latched condition, the TMP indicator will remain red even after the laser has cooled sufficiently to begin operation. To reset an over temperature fault, lower coolant temperature below 28 °C and then cycle DC power (remove DC power, wait 30 seconds, reapply DC power). When the RDY indicator illuminates, lasing is enabled after the five-second delay. If the TMP indicator remains red after cycling power, continue to flow cooling water through the laser for a few more minutes and/or verify the coolant flow rate and then cycle DC power again.

Under Voltage fault

An under voltage fault occurs when DC input voltage falls below a preset limit of 46.5 VDC. This fault is indicated by the RDY LED flashing 1 blink. The Laser Ready output Opens under these conditions. To reset an under voltage fault, first correct the voltage problem and ensure that 48 VDC is measured at the laser's DC power terminals. Next, cycle DC power off and then on again. When the RDY LED illuminates, the Laser Ready output Closes, and lasing is enabled after the five-second delay. Apply a PWM Command signal, provided the SHT indicator is illuminated blue.

Over Voltage fault

An over voltage fault occurs when DC input voltage rises above a preset limit of 49.5 VDC. This fault is indicated by the RDY LED flashing 2 blinks. Under these conditions the Laser Ready output Opens. To reset an over voltage fault first correct the voltage problem and ensure 48 VDC is measured at the laser's DC power terminals. Next, cycle DC power off and then on again. When the RDY LED illuminates, the Laser Ready output Closes, and lasing is enabled (after a five-second delay) provided a PWM Command signal is applied, and the SHT indicator is illuminated blue.

Maintenance/ Troubleshooting

Troubleshooting Status LED's

RF Drive Switch fault

An RF Drive Switch fault occurs during power-up. RF drive switch faults are triggered by either of the following: the tube fails to breakdown, or the RF Driver's 48-volt switching circuitry fails. A RF drive switch fault is indicated when the RDY LED flashes 3 blinks and the Laser Ready output Closes. If a RF Drive Switch fault occurs, the laser requires service—Contact SYNRAD Customer Service or a SYNRAD Authorized Distributor.

PWM Drive fault

A PWM Drive fault signals a problem in the laser's internal RF circuitry and is indicated by a flashing RDY LED that blinks 4 times. If a PWM Drive fault appears, the laser requires service—please contact SYNRAD Customer Service or a SYNRAD Authorized Distributor.

DC Pre-Charge fault

A DC Pre-Charge fault indicates that 48 VDC is not available at the input of one or more of the RF modules. The RDY LED will flash in a 5 blink pattern. When this occurs, the Laser Ready output Opens. If a DC Pre-Charge fault appears, the laser requires service—please contact SYNRAD Customer Service or a SYNRAD Authorized Distributor.

No-Strike fault

A No-Strike fault occurs when the laser discharge does not strike (gas does not breakdown). During No-Strike faults lasing is limited to a maximum 6.25% duty cycle (at a PWM Command frequency of 5 kHz), or 5% at the user's specified frequency during PWM signal application. In addition to the SHT indicator flashing continuously an error message appears on the p250's web page.

Humidity fault

During laser operation, monitor information on the p250's web page including the relative humidity (RH) value. When properly conditioned purge gas is flowing, the measured RH value should drop below 10% within 10-15 minutes. If the RH value doesn't drop below approximately 10% increase the gas flow rate to the maximum specified value. Refer to purge gas specifications in the Technical Reference chapter within the connection section. If the RH value continues to rise and reach 95%, lasing is halted and a fault is displayed in red within the error message section of the web page.

Blinking Shutter LED fault

Possible Causes:

- A No-Strike fault has occurred, possibly due to cold environmental conditions (common when overnight temperatures are low) that may prevent the gas from breaking down into a plasma state.

When this occurs, it may take 30 to 60 seconds for gas breakdown so the laser can begin normal daily operation. There are three methods to force breakdown and clear the no-strike fault: (1) Apply tickle pulses or a PWM Command signal ($\leq 6.25\%$ duty cycle) for 30 to 60 seconds.

Maintenance/ Troubleshooting

Troubleshooting Status LED's

When the gas breaks down into a plasma state, the laser will recover and begin lasing at the commanded power level without cycling DC power. (2) Apply a single 20 μ s PWM pulse (at 5 kHz) while monitoring the Fault Detected output. If the output closes, wait a minimum of 52 ms for the output to open and then apply another 20 μ s PWM pulse. Repeat this sequence until no fault is detected—which typically occurs in less than one second. Be aware that applying 20 μ s breakdown pulses in rapid succession may cause laser output. (3) Apply a PWM Command signal (at < 5% duty cycle) until the fault clears—typically less than 30 seconds. With either method, when breakdown does occur, lasing will begin immediately at the commanded PWM parameters without cycling DC power. If the No-Strike condition persists, contact SYNRAD or a SYNRAD Authorized Distributor.

Frequency Limit fault

Possible Causes:

- The 100 kHz PWM frequency limit has been exceeded.

Lasing is disabled when the input frequency limit is exceeded. When the input drops below 100 kHz, the laser will begin lasing immediately at the commanded PWM parameters without cycling DC Power.

Duty Cycle/Pulse Width Limit fault

Possible Causes:

- The applied PWM Command signal is outside the laser's operating parameters.

Lasing is disabled when a constant 5V signal (100% duty cycle) is applied. When the PWM duty cycle drops below 100%, the laser will begin lasing immediately at its 50% PWM duty cycle limit. If the commanded duty cycle is above 50% or the PWM pulse length exceeds 1000 μ s, adjust the pulse length until the PWM input is brought within limits. The laser will then lase at the commanded PWM parameters.

When a duty cycle or pulse width limit fault is detected, the SHT LED flashes 3 blinks and the Fault Detected output Closes to indicate (1) a constant 5V PWM signal is applied, forcing the PWM duty cycle to 100%—full continuous wave operation; (2) the applied duty cycle is above the 50% limitation; or (3) the applied pulse length exceeds 1000 μ s in duration. When condition 1 occurs, the laser begins lasing immediately at 50% once the PWM duty cycle drops below 100%. For condition 2, the laser begins lasing immediately at the commanded PWM parameters, the duty cycle is automatically limited to 50%. For condition 3, the laser begins lasing immediately at the commanded PWM parameters, the pulse duration is automatically limited to 1000 μ s.

Maintenance/ Troubleshooting

Troubleshooting Status LED's

Cleaning optical components

Debris or contaminants on external beam delivery components may affect laser processing and lead to damage or failure of the optics and/or the laser.

Warning **Serious** **personal** **injury**



Ensure that DC power to the laser is turned off and locked out before inspecting optical components in the beam path.

Invisible CO₂ laser radiation is emitted through the aperture.

Corneal damage or blindness may result from exposure to laser radiation.

A risk of exposure to toxic elements, like zinc selenide, may result when certain optical or beam delivery components are damaged.

In the event of damage to laser, marking head, or beam delivery optics contact SYN-RAD or the optics manufacturer for handling instructions.

Caution **Possible** **Equipment** **Damage**



Even small amounts of contamination on optics in the beam path can absorb enough energy to damage the optic. Inspect beam delivery optics periodically for signs of contaminants and carefully clean as required. In dirty environments, purge laser optics using filtered air or nitrogen to prevent vapor and debris from accumulating on optical surfaces.

Important – Pulstar p250 lasers have several beam conditioning optics between the output aperture and the faceplate. To prevent dust and debris from damaging these optical surfaces, always connect nitrogen or filtered air to the laser's Gas Purge port.

Maintenance/ Troubleshooting

Troubleshooting Status LED's

Symptom:

- The laser loses power over time; laser output power must be increased to maintain performance.

Possible Causes:

- Beam delivery optics are coated by vapor residue or debris.

Shut down the laser and carefully inspect each optic in the beam delivery path. If the optic requires cleaning, refer back to Maintenance for cleaning instructions. Use only recommended cleaning materials (see the first table in this chapter) to prevent scratching delicate optical surfaces. If the focusing optic is pitted, it must be replaced immediately. Because of the extremely high power density of Pulstar lasers, pits or debris on the lens surface may absorb enough energy from the focused beam to crack the lens. If this happens, other optics in the beam path may be contaminated or damaged as well.

When the application requires air (instead of nitrogen) as an assist gas, we recommend the use of breathing quality air available in cylinders from a welding supply company. Because compressed shop air contains minute particles of oil and other contaminants that will damage optical surfaces, it must be carefully filtered and dried before use as a purge or assist gas. Refer to the purge gas specifications, in the Introduction chapter of this manual and the getting started chapter in the Operation Manual for filtering and drying specifications.

index

Symbols

- +5 VDC Auxiliary Power 57
- +5 VDC output 59
 - signal description, 59
- +24 VDC 68
- +24 VDC Auxiliary Power 57
- +24 VDC output 59
 - signal description, 59

A

- American National Standards Institute (ANSI) 20
- Aperture
 - see Laser aperture
- Assist gas purity
 - specifications, 34, 35, 39, 45
- Aux. DC Power Ground 59
 - signal description, 59
- Auxiliary DC power 58
 - +5 VDC, 59, 60
 - +24 VDC 59
 - +24 VDC, 59
 - Aux. DC Power Ground 59
 - Aux. DC Power Ground, 59
 - internal wiring diagram, 59
- Auxiliary DC Power Ground
 - pin description, 58

C

- Caution
 - condensation, , 29, 7, 32, 37, 45, 56
- CDRH 23
- Chiller
 - temperature setpoint, 40
- Class IV safety features 26
- Code of Federal Regulations (CFR) 23, 24
- Collimator 38
- Command signal 44, 55
 - base frequency, 44
 - duty cycle, 44
 - signal amplitude, 44
- Condensation damage 91
- Control signals 43
 - Tickle pulse, 43
- Cooling tubing 12
- Customer Service 10

D

- Daily inspections 91
- Danger

- laser radiation, , 17, 20, 29, 18, 19, 32, 33, 43, 44, 61
- DC Power cable 91
- DC Power Cables 14, 70
 - min bend radius, 70
- Delivery optics 37
- Disabling Firestar 91
- Divergence 37

E

- Expander/collimator 38

F

- Final Test report 13
- Flowchart
 - laser start-up, 96
- Flow rate 100
- Food and Drug Administration (FDA) 23
- Fuse 13

G

- Gas purge kit 13
- Gas purge specifications 39
- GND terminal 31

H

- Hazard information 18
 - label locations, 22
 - terminology, 18

I

- Input circuit
 - equivalent schematic, 62
 - specifications, 63
- Input Common 62
 - pin description, 58
- Input signals
 - PWM Return, 60
 - Remote Interlock, 60, 61
- Inspections
 - daily, 91
- Interlock
 - see Remote Interlock
- Interlock Open
 - pin description, 58, 64
- IP Address 71, 72
 - changing, 76

K

- Keyswitch functions
 - integrating, 83

index

L

Label locations 22
Laser Active 57
 pin description, 64
Laser aperture 30
Laser Institute of America (LIA) 21
Laser Ready 64
 pin description, 57, 64

M

Maintenance
 daily inspections, 91
 disabling Firestar, 91
 storage/shipping, 92
MSDS 93

O

Occupational Safety and Health Administration
 (OSHA) 21
Optical accessories mounting 30
Output circuit
 equivalent schematic, 65
 specifications, 66
Output Common 63, 64, 69, 84
 pin description, 58, 64
Output signals
 Laser Ready, 64
 Output Common, 64
 Over Temperature, 64
 Shutter Open, 64
Over Temperature 64
Over Temperature output 100

P

PLC
 multiple inputs, 69
 multiple outputs, 67
 Remote Interlock output, 67
PWM Input 44, 60, 61
 pin description, 58
PWM Input signal
 description, 61
 specifications, 63
PWM Return 44, 60
PWM Return signal
 description, 60

Q

Quick Start Plug 14
 wiring diagram, 61

R

Ready indicator , 31, 100
Reference materials 10
Remote Interlock 57, 60
 customer-supplied circuit, 66
 from PLC, 67
Remote Interlock functions 84
Remote Interlock indicator 84
Remote Interlock input 83, 84, 39, 98
Remote Interlock (INT) indicator 98
Remote Interlock signal
 specifications, 63
Remote Reset/Start Request 57, 60
Remote Reset/Start Request input 39
Remote Reset/Start Request signal
 specifications, 63
RF modules 74
RoHS 25

S

Sales and Applications 10
Shorting plug
 see Quick Start Plug
Shutter indicator 31
Shutter Open 64
 pin description, 58, 64
Shutter Open request
 pin description, 58
Shutter Open Request 61
Shutter Open request input 39
Shutter Open Request signal
 specifications, 63
Shutter switch 39
Specifications
 assist gas purity, 34, 35, 39, 45
Status indicators 31
Storage/shipping 92

T

Technical overview
 laser tube, 34
Technical Support 10
Temp indicator 100
Tickle pulse 43
Trademark information 8
Troubleshooting 93
 operational flowchart, 96

index

U

- UC-2000 Laser Controller 43
- User I/O
 - connection summary, 56
 - pin descriptions, 57, 58, 59, 60, 61, 62, 64
- User I/O connections
 - input/output signals 56
 - sample input circuits, 66
- User I/O connector 83, 74, 84, 31

W

- Warning
 - air contaminants, 7, 8
- Warranty information 9
- Water Out/In ports 31
- Web interface
 - accessing, 71
 - web page layout, 71

Tables and Figures

- | | |
|---|----|
| Table 1-1 p250 ship kit contents. | 13 |
| Figure 1-1 p250 ship kit contents. | 14 |
| Figure 1-2 Anatomy of a model number. | 16 |
| Figure 2-1 Labeling terms and definitions. | 18 |
| Figure 2-2 Always wear safety glasses . | 20 |
| Table 2-1 Class 4 safety features. | 26 |
| Table 2-2 European Union Directives. | 27 |
| Figure 2-3 p250 Declaration Document. | 28 |
| Figure 3-1 Pulstar OEM p250 front panel controls and indicators. | 30 |
| Figure 3-2 Pulstar OEM p250 rear panel controls and indicators. | 31 |
| Figure 4-1 Hybrid waveguide/unstable resonator design. | 34 |
| Figure 4-2 Pulstar p250 beam ellipticity. | 35 |
| Figure 4-3 Converting 45° linear polarization to circular polarization. | 36 |
| Table 4-1 Assist gas purity specifications. | 39 |
| Table 4-2 Purge gas specifications. | 39 |
| Table 4.3 Dew point temperatures. | 41 |
| Figure 4-4 PWM command signal wave form. | 45 |
| Figure 4-5 Typical power curve. | 46 |
| Figure 4-6 Representative output energy profile-5% duty cycle, 100Hz, time base 200 µs/Div. | 47 |
| Figure 4-7 Representative output energy profile-5% duty cycle, 1kHz, time base 50 µs/Div. | 47 |
| Figure 4-8 Representative output energy profile-5% duty cycle, 10kHz, 50 µs/Div time base. | 48 |
| Figure 4-9 Representative output energy profile-10% duty cycle, 1kHz, 200 µs/Div. | 48 |
| Figure 4-10 Representative output energy profile-10% duty cycle, 10 kHz, 20.0 µs/Dev time base. | 49 |
| Figure 4-11 Representative output energy profile-10% duty cycle, 50 kHz, 5.0 µs timebase. | 49 |
| Figure 4-12 Representative output energy profile-20% duty cycle, 1 kHz, 100 µs/Dev time base. | 50 |
| Figure 4-13 Representative output energy profile-20% duty cycle, 5 kHz, 50 µs/Div time base. | 50 |
| Figure 4-14 Representative output energy profile-20% duty cycle, 50 kHz, 5.0 µs/Dev time base. | 51 |
| Figure 4-15 Representative output energy profile-20% duty cycle, 100 kHz, 5.0 µs timebase. | 51 |
| Figure 4-16 Representative output energy profile-40% duty cycle, 1 kHz, 200 µs/Dev time base. | 52 |
| Figure 4-17 Representative output energy profile-40% duty cycle, 5 kHz, 50.0 µs/Dev time base. | 52 |
| Figure 4-18 Representative output energy profile-40% duty cycle, 50 kHz, 5.0 µs/Dev time base. | 53 |
| Figure 4-19 Representative output energy profile-40% duty cycle, 100 kHz, 5.0 µs/Dev time base. | 53 |
| Figure 4-20 Representative output energy profile-50% duty cycle, 100 kHz, 5.0 µs/Dev time base. | 54 |
| Figure 4-21 Representative output energy profile-45% duty cycle, 10 kHz, 5.0 µs/Dev time base. | 54 |
| Figure 4-22 User I/O connector pinouts. | 56 |
| Table 4-4 User I/O pin descriptions. | 57 |
| Figure 4-23 Auxiliary DC power diagram. | 59 |
| Table 4-4 User I/O pin descriptions (Continued). | 59 |
| Figure 4-24 Quick Start Plug wiring diagram. | 61 |
| Table 4-4 User I/O pin descriptions (Continued). | 62 |
| Figure 4-25 Input equivalent schematic. | 62 |
| Table 4-5 Input circuit specifications. | 63 |
- | | |
|--|----|
| Table 1-1 p250 ship kit contents. | 13 |
| Figure 1-1 p250 ship kit contents. | 14 |
| Figure 1-2 Anatomy of a model number. | 16 |
| Figure 2-1 Labeling terms and definitions. | 18 |
| Figure 2-2 Always wear safety glasses or protective goggles with side shields. | 20 |
| Table 2-1 Class 4 safety features. | 26 |
| Table 2-2 European Union Directives. | 27 |
| Figure 2-3 p250 Declaration Document. | 28 |
| Figure 3-1 Pulstar OEM p250 front panel controls and indicators. | 30 |
| Figure 3-2 Pulstar OEM p250 rear panel controls and | |

index

Tables and Figures

indicators.	31	Table 4-4 User I/O pin descriptions.	57
Figure 4-1 Hybrid waveguide/unstable resonator design.	34	Figure 4-23 Auxiliary DC power diagram.	59
Figure 4-2 Pulstar p250 beam ellipticity.	35	Table 4-4 User I/O pin descriptions (Continued).	59
Figure 4-3 Converting 45° linear polarization to circular polarization.	36	Figure 4-24 Quick Start Plug wiring diagram.	61
Table 4-1 Assist gas purity specifications.	39	Table 4-4 User I/O pin descriptions (Continued).	62
Table 4-2 Purge gas specifications.	39	Figure 4-25 Input equivalent schematic.	62
Table 4.3 Dew point temperatures.	41	Table 4-5 Input circuit specifications.	63
Figure 4-4 PWM command signal wave form.	45	Table 4-4 User I/O pin descriptions (Continued).	64
Figure 4-5 Typical power curve.	46	Figure 4-26 Output equivalent schematic.	65
Figure 4-6 Representative output energy profile-5% duty cycle, 100Hz, time base 200 μ s/Div.	47	Table 4-6 Output circuit specifications.	66
Figure 4-7 Representative output energy profile-5% duty cycle, 1kHz, time base 50 μ s/Div.	47	Figure 4-27 Customer-supplied interlock.	66
Figure 4-8 Representative output energy profile-5% duty cycle, 10kHz, 50 μ s/Div time base.	48	Figure 4-28 Customer-supplied interlock, negative voltage.	66
Figure 4-9 Representative output energy profile-10% duty cycle, 1kHz, 200 μ s/Div.	48	Figure 4-29 PLC driven interlock signal.	67
Figure 4-10 Representative output energy profile-10% duty cycle, 10 kHz, 20.0 μ s/Dev time base.	49	Figure 4-30 Multiple PLC driven inputs.	67
Figure 4-11 Representative output energy profile-10% duty cycle, 50 kHz, 5.0 μ s timebase.	49	Figure 4-31 Pulstar output driving warning lamp.	68
Figure 4-12 Representative output energy profile-20% duty cycle, 1 kHz, 100 μ s/Dev time base.	50	Figure 4-32 Pulstar output driving relay.	68
Figure 4-13 Representative output energy profile-20% duty cycle, 5 kHz, 50 μ s/Div time base.	50	Figure 4-33 Pulstar output driving PLC input module.	69
Figure 4-14 Representative output energy profile-20% duty cycle, 50 kHz, 5.0 μ s/Dev time base.	51	Figure 4-34 Pulstar p250 home page.	73
Figure 4-15 Representative output energy profile-20% duty cycle, 100 kHz, 5.0 μ s timebase.	51	Figure 4-35 Pulstar p250 event log page.	75
Figure 4-16 Representative output energy profile-40% duty cycle, 1 kHz, 200 μ s/Dev time base.	52	Figure 4-36 Pulstar p250 Change IP Address page.	76
Figure 4-17 Representative output energy profile-40% duty cycle, 5 kHz, 50.0 μ s/Dev time base.	52	Figure 4-37 Windows Control Panel.	78
Figure 4-18 Representative output energy profile-40% duty cycle, 50 kHz, 5.0 μ s/Dev time base.	53	Figure 4-38 Programs and Features dialog.	78
Figure 4-19 Representative output energy profile-40% duty cycle, 100 kHz, 5.0 μ s/Dev time base.	53	Figure 4-39 Windows Features dialog.	78
Figure 4-20 Representative output energy profile-50% duty cycle, 100 kHz, 5.0 μ s/Dev time base.	54	Figure 4-40 Local Area Connection Properties dialog.	79
Figure 4-21 Representative output energy profile-45% duty cycle, 10 kHz, 5.0 μ s/Dev time base.	54	Figure 4-41 Internet Protocol (TCP/IP) Properties dialog.	80
Figure 4-22 User I/O connector pinouts.	56	Figure 4-42 Configure IP Address link on Pulstar p250 home page.	81
		Figure 4-43 Pulstar p250 Change IP Address page.	81
		Figure 4-44 Pulstar p250 web browser display.	82
		Table 4-5 Pulstar p250 general specifications.	85
		Figure 4-45 Pulstar p250 outline & mounting dimensions.	87
		Figure 4-46 Pulstar p250 outline & mounting dimensions (mounting feet removed).	88
		Figure 4-47 Pulstar p250 packaging instructions.	89
		Table 5.1 Required cleaning materials.	93
		Figure 5-2 Pulstar p250 Flow Chart.	95
		Figure 5-2 Pulstar p250 LED Status States.	96
		Table 5.2 p250 Input/Output & LED Status Signals.	97
		Index	105