

# Series 48™ Air Cooled Laser, FH Marking Head, kit, & WMPv6

SYNRAD  
a flywire company

## Important Note:

- Read all ⚠ Danger, ⚠ Warning, ⚠ Caution terms, symbols, and instructions located in the (Laser Safety Hazard information) sections in the Series 48 Laser Operation Manuals. A PDF version is available Online at: <http://synrad.com/synrad/docroot/resources/libraries/manuals>.

## Laser and Marking Head Unpacking:

- Under your Series 48 laser at the bottom of the box you will find the **mounting hardware/components kit**. The **Marking Head hardware/components kit** is located in the top shipping **components box**. Don't forget to save all shipping containment including plug covers and set them aside.

1.1 Lifting the **Series 48** laser correctly by holding in the middle, do not carry laser by the mounting feet, this can disturb alignment.



1.2 **Series 48 laser** mounting/component kit for the laser and the FH Marking Head (In set).



## Important Note:



**Keep All Foam and Packaging**, you will need to re-use it when moving your laser to prevent damage that could void your warranty. Refer to this guide and the Technical Reference chapters in the laser's Operation Manual when re-packaging for shipping and/or relocation. Remove all accessory items not originally attached to the laser prior to re-packaging for shipping.

- Upon arrival, inspect all shipping containers for signs of damage. If you discover shipping damage, document the damage (photographically if possible), then immediately notify the shipping carrier (responsible party for any transportation damage) and SYNRAD®. See the inventory section within the Introduction chapter of the Operation Manual for packaging list(s).

**Note: If shipped completely assembled,** jump to the cooling section of this guide.

# Series 48™ Air Cooled Laser, FH Marking Head, kit, & WMPv6

SYNRAD  
a fluents company

Lift both the both the marking head and the foam packaging out of the box.



Top Foam notch



Bottom Foam notch

2.1 Place the unit with foam packaging on a firm surface, remove foam end cap, notice foam notch locations for ports and interfaces.

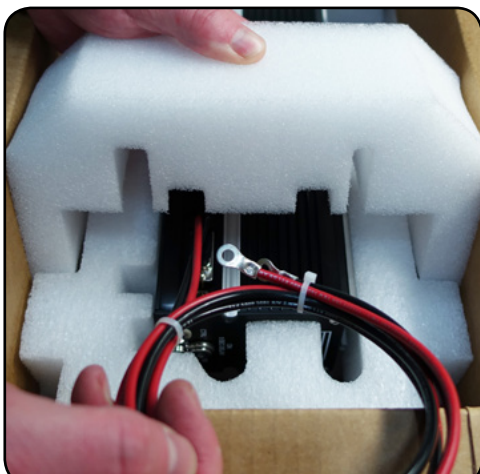

The wire harness can be damaged in shipping if not re-packaged as shipped!

Don't forget to remove the three (3) cap screws on the lens aperture cover if a focusing lens is ordered.



**Important Note:**



**Caution!** When packing the laser or the marking head for relocation or shipment, nothing can be on the sides of the units at any time as damage will occur. The skin on the sides of the laser is fragile! All box components must be stowed as they were when they arrived.

Please refer to the examples above and the laser's Operation Manual drawings located at the end of the Technical Reference Chapter.

series48

# Series 48™ Air Cooled Laser, FH Marking Head, kit, & WMPv6

SYNRAD  
a Fluoroko company

## Mounting your Laser:

**Note:** ! Mounting feet and/or rails are optional, for complete details, refer to the Series 48 Operator's Manual. Remove the laser aperture self-adhesive film before mounting to the rail.

Don't tighten the path enclosure screws until the laser is mounted securely to the rail.

**SYNRAD does not recommend mounting lasers in a vertical, (head and/or tail down) position.** Please contact the factory for limitations as a vertical orientation increases the risk of damage to the lasers optics.

The laser's mounting feet are precisely aligned and shimmed at the factory to ensure alignment between the marking head and the Mounting Rail. Do not loosen or remove the mounting feet from the laser. See the FH Flyer Marking Head Operator's Manual for further details.

- 3. Before** mounting the laser to the rail, ensure the **aperture seal is removed**.
- 4.** Locate the **Mounting Hardware Kit** (  ) path enclosure tube, marking head & laser hardware.

### 3.1 Remove the aperture seal.

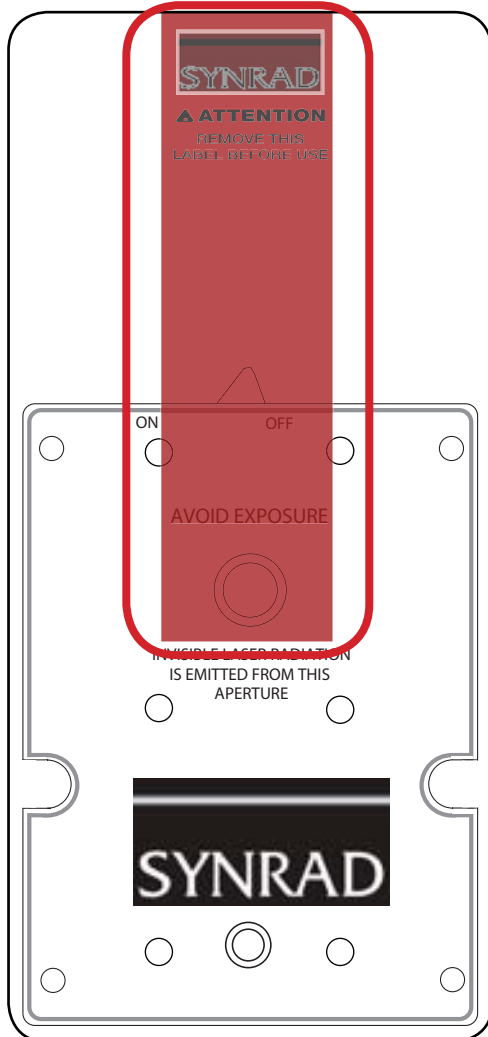

### 4.1 Path enclosure tube.



### 4.2 6-32 x 1" Laser Mounting socket head capscrews.



### 4.3 1/4-20 x 3/4" Marking Head Mounting socket head capscrews.



### 4.4 8-32 x 1/4" Marking Head Mounting button head socket screws.



### 4.5 Laser & Marking Head Mounting Kit(s).

# Series 48™ Air Cooled Laser, FH Marking Head, kit, & WMPv6

SYNRAD  
A THORlabs company

## Mounting your Marking Head onto a Rail:

- Remove the **dust cover** & set aside, from the rear end of the **marking head**, unwrap the **mounting rail**, set it on a firm surface. Orient the rail so that the **I-bracket can be placed on the notch end of the rail**.
- Mount the **I-bracket** to the **rail** using the (4) 1/4-20 x 3/4" socket head capscrews as shown in the following figures.

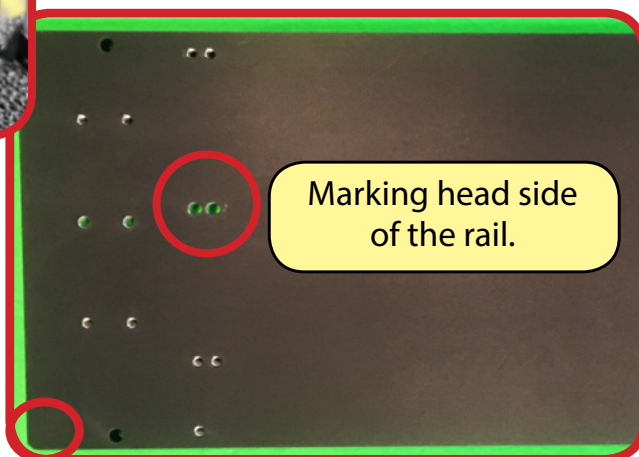
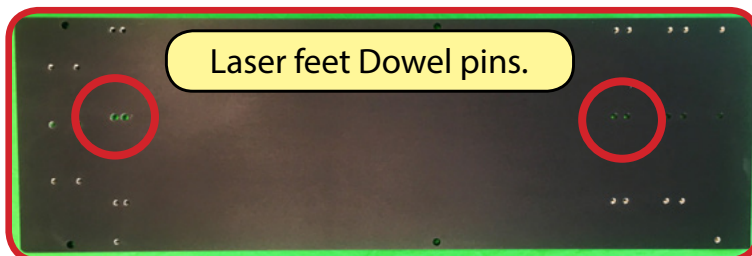

6.1 Notch end of the rail.

6.2 I-bracket mounting holes and notch locations on the rail.



6.3 Secure the I-bracket to the rail.

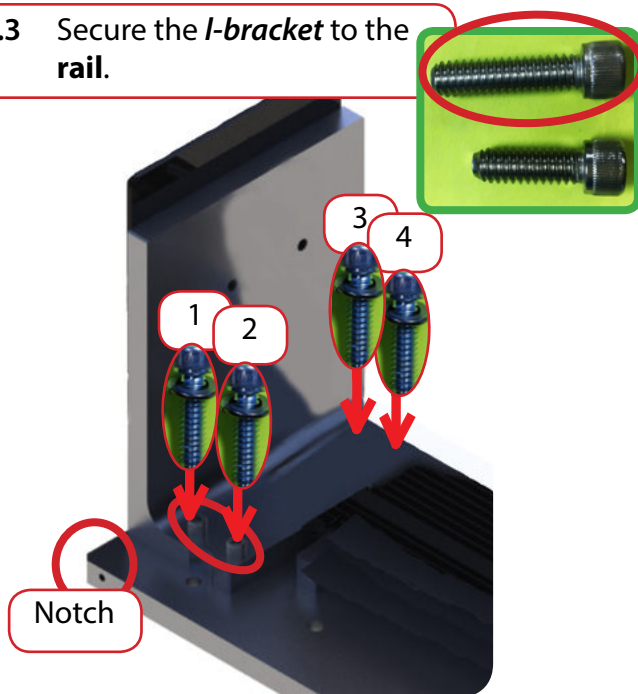

## Mounting your Marking Head onto a Rail (Continued):

7. Place the **marking head** on the **I-bracket** as below. Assure the dowel pins protrude through the **I-bracket**. Install and tighten the three (3) 1/4-20 x 3/4" socket head capscrews.

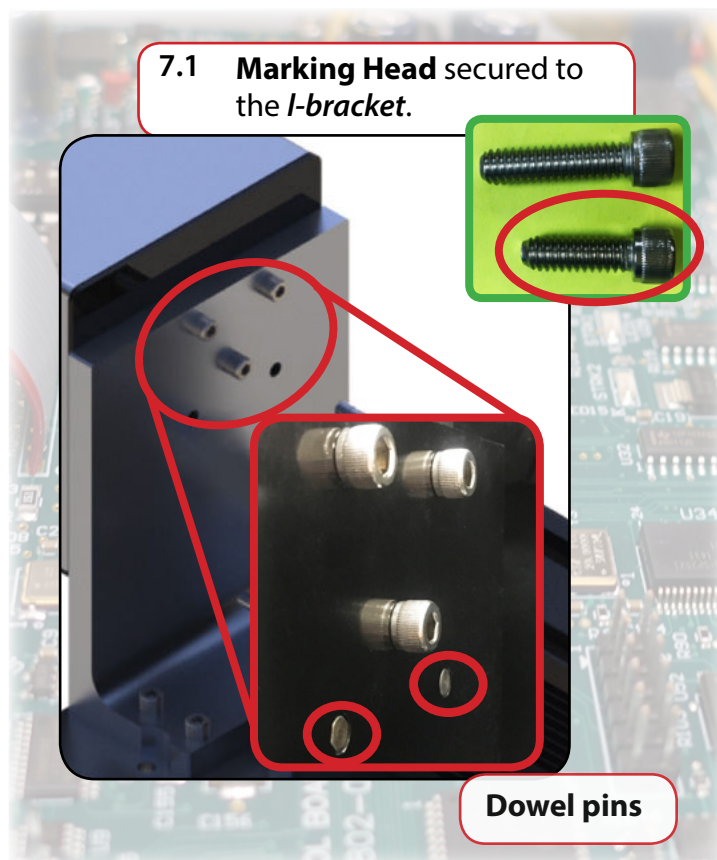

### Important Check Point:



The anodized blanking plate & dust cover are removed from the Marking Head. The Marking Head is mounted adjacent to the **notch on the rail**.

Refer to the appropriate chapter for more mounting details and the technical drawings in the Series 48 Operation Manual.

## Mounting your Laser onto a Rail:

### Important

#### Note:



Do not use any type of jackscrew arrangement as this will twist the baseplate and may distort the tube.

- Place the **laser** onto the **rail** with the front end facing the **marking head**. Ease the **laser** forward so the dowel pins on both mounting feet drop into their respective holes on the rail. Install/tighten the four (4) 6/32 x 1" socket head capscrews. See the figure(s) below.

8.1 Attach the **laser by it's mounting feet** securely to the rail.

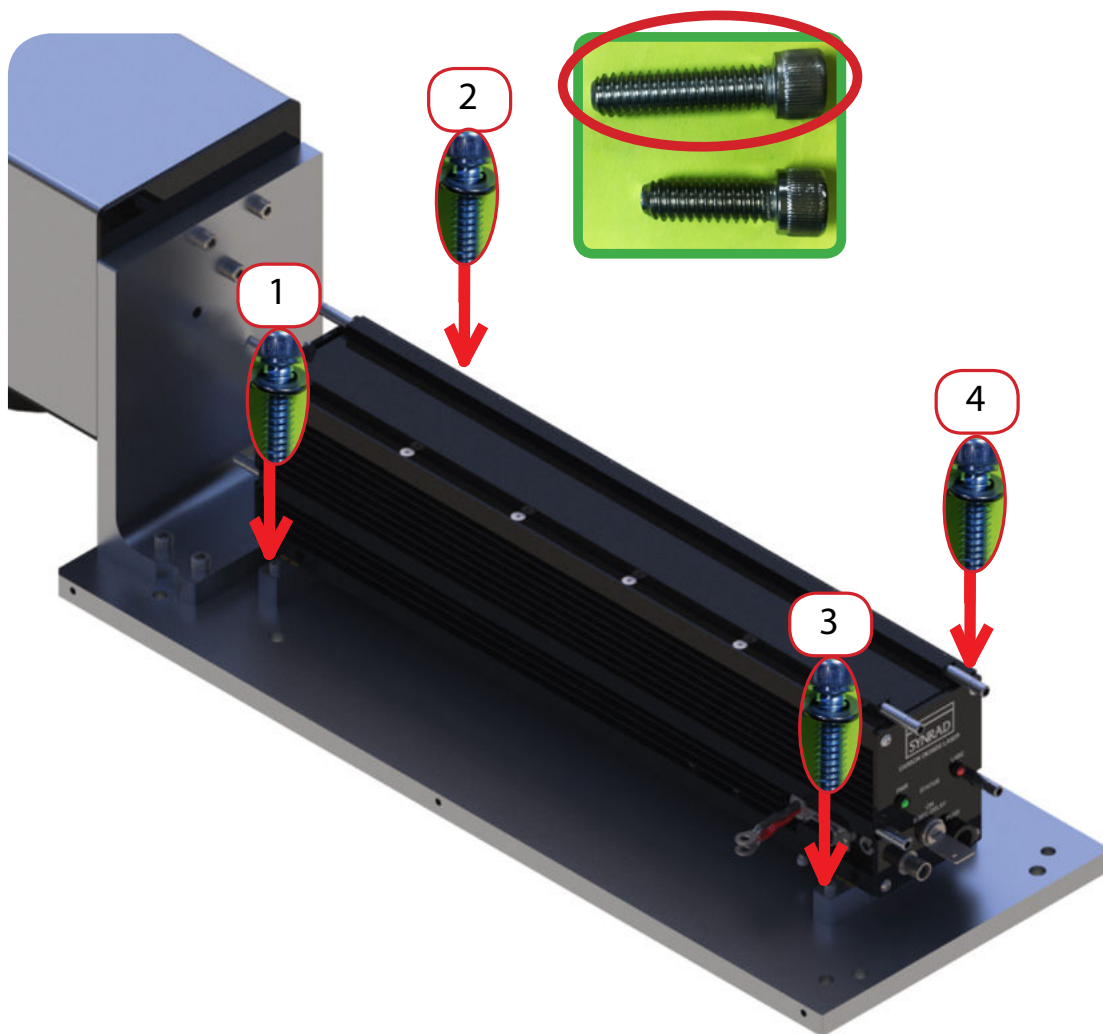

### Important

#### Note:



**Calibration void if shim bolts are adjusted**, if your laser has mounting feet as shown above, careful not to carry or handle the laser by the feet to minimize misalignment risk.

## Mounting your Laser onto a Rail (Continued):

9. After both the laser and the marking head are mounted to the rail, place the spring-loaded path enclosure tube as shown below.

9.1 Assemble and compress the **spring-loading path enclosure tube** and place the larger end facing the marking head (on the L-bracket).

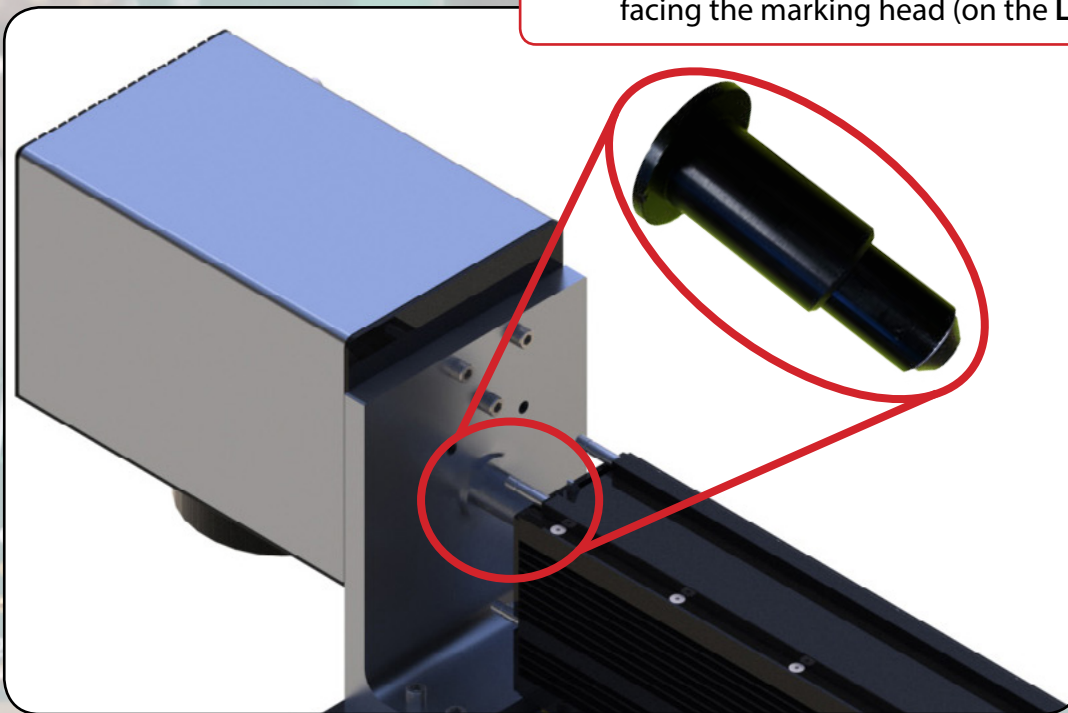

### Important Note:



Consult the factory for further mounting angle guidance outside >20% from the horizontal. When mounting the laser, use only one metric or SAE fastener per mounting tab on the baseplate. Do not use any type of jackscrew arrangement as this will twist the baseplate and may distort the tube.

### Note:



The recommended mounting orientation for the Series 48 is horizontal. Refer to the drawings within the Series 48 Operation Manual, see the Technical Reference chapter for further information.

## Mounting your Laser onto a Rail (Continued):

10. Secure the path enclosure tube to the I-bracket with four (4) 8-32 x 1/4" button head socket screws as shown below.

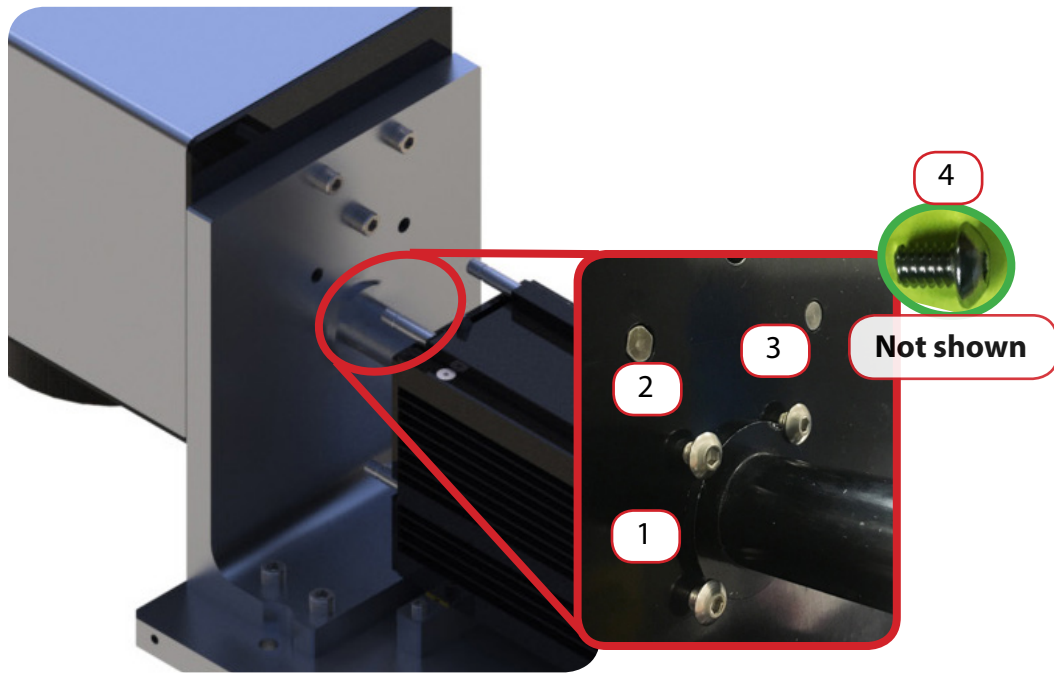

10.1 Assure the laser & marking head is securely mounted to the rail beforehand.

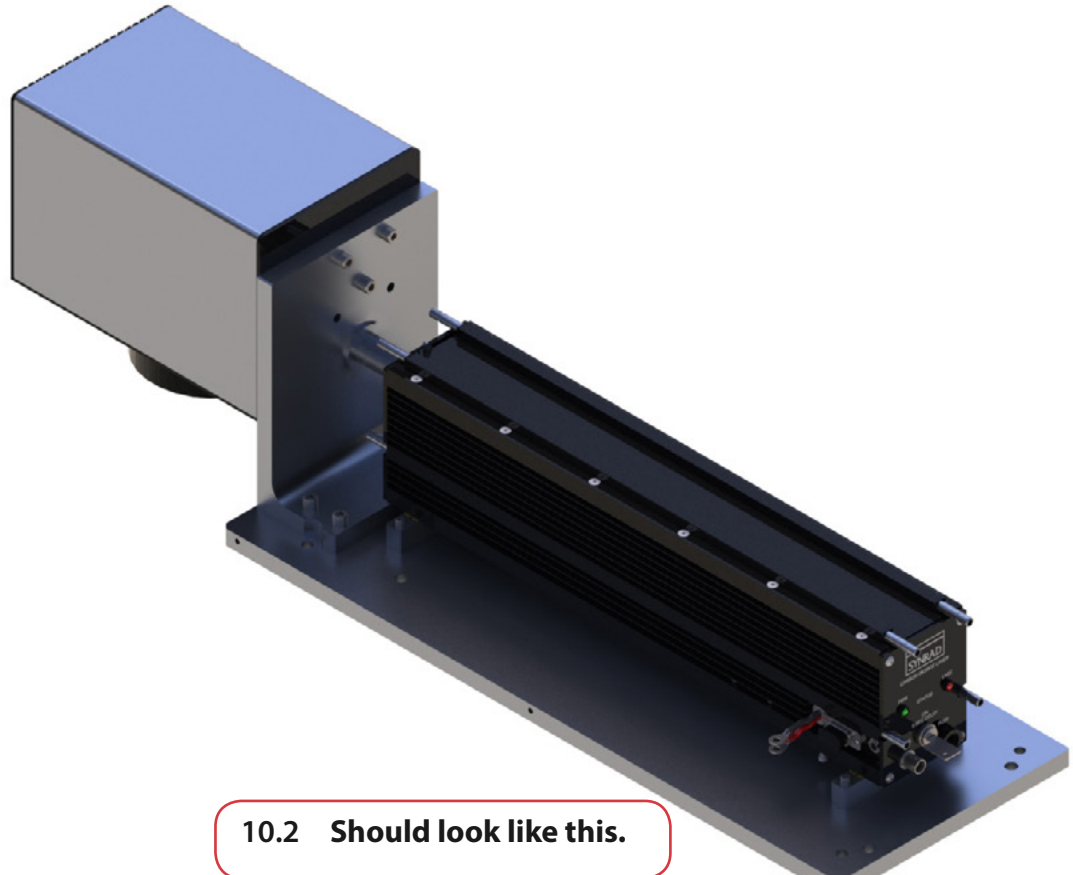

10.2 Should look like this.



# Series 48™ Air Cooled Laser, FH Marking Head, kit, & WMPv6

SYNRAD  
a flywire company

## Cooling:

### Important

Because Series 48 lasers are OEM products, they do not include cooling fans.

### Note:

Customers must provide some type of air or water cooling to prevent the laser from overheating.



Refer to the cooling specifications in the Technical References chapter of the Series 48 Operation manual.

11. The fans must have at a minimum 2.25" (52.7 mm) clearance between the unit and the wall or any obstructive surface.

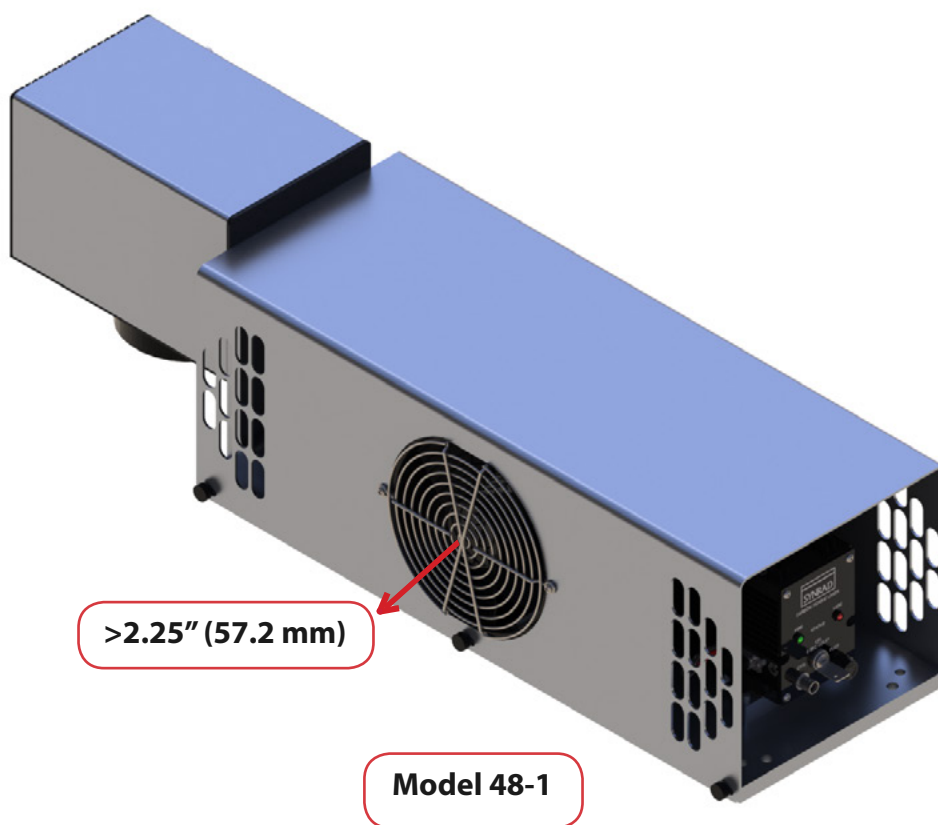

12. If 48-1/2 water cooling is desired, please see the Series 48 water cooling Quick Start Guide located on our website.

# Series 48™ Air Cooled Laser, FH Marking Head, kit, & WMPv6

SYNRAD  
A THORlabs company

## Power Connections:

**Note:** The negative (–) side of the DC input to the laser is internally connected so that the laser chassis serves as DC power ground.

You should isolate the laser's DC power supply so that the only grounded connection is at the laser. Alternatively, you can mount the laser chassis on an insulating pad or film in order to electrically isolate the laser when other equipment is grounded to the laser's DC power supply.

**Warning**  
Serious  
personal  
injury



**Always use shielded cable** when connecting your PWM Command signal source to PWM Positive/PWM Negative inputs.

In electrically-noisy environments, **long lengths of unshielded wire act like an antenna and may generate enough voltage to trigger un-commanded lasing.**

13. Connect the Marking Head **DC power VDC** cable into the **Marking Head's power supply**.



13.1 DC Power connection locations (for the Marking Head) to the power supply.

## Power Connections (Continued):

### Important Note:

The 48-1 laser requires a DC power supply capable of providing 30 VDC at 7 A minimum; the 48-2 laser requires 30 VDC at 14 A.



For the 48-1 laser, SYNRAD® recommends the DC-1, a 30 V, 250 W DC power supply; for 48-2 lasers, we recommend the PS-2, a 30 V, 750 W DC power supply. Please refer to the corresponding power supply manual located on our website.

If substituting power supplies, use a well-regulated DC power supply in the range of 30 V to 32 V with no more than 3 V overshoot under a 10–90% modulation load. The use of short leads and terminations rated for the appropriate output current is recommended.

Do not reverse polarity when connecting the DC Power cable between the DC power supply and the Series 48 laser.

Attach the red (+) wire(s) from the DC Power cable to the positive (+) 48 VDC output terminal and attach the black (-) wire(s) from the DC Power cable to the negative (-) 48 VDC output terminal.

14. Connect the negative (**black**) and the **positive (red)** DC power into the **laser's power** supply.



## Control Connections (Continued):

15. Connect the *laser's* control BNC interface to the **Marking Head's** laser control port.



16. Connect the *other end of the BNC cable to the control input, labeled CTRL*, located on the rear end of the laser.

16.1 Control connection locations (for the Marking Head).

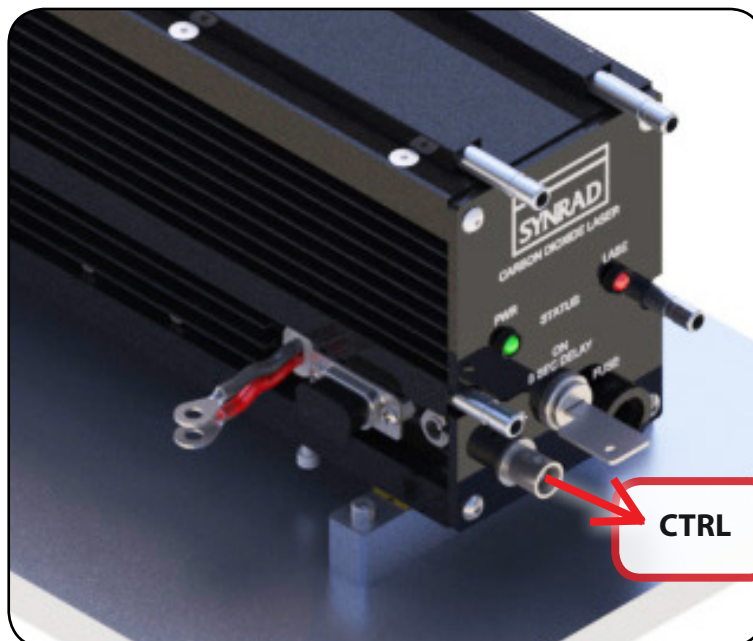

## Control Connections (Continued):

17. The Marking Head's Ethernet connector is ready to be plugged into the PC's Ethernet port.

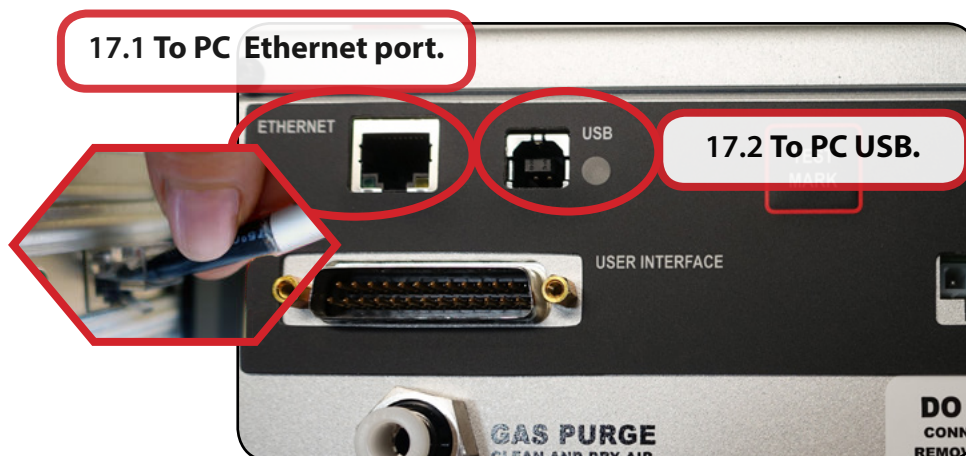

**Note:** If the **PC to USB communication** cable is the desired communication method from the FH Flyer Marking Head to the PC, please reference the connection section within the FH Series Flyer Operator's Manual.

Laser Markers are pre-configured at the factory to a fixed address of 192.168.100.100. This allows you to make a peer-to-peer Ethernet connection. Your computer's Ethernet settings are determined by your facility's computer network. The FH Marking Head requires a connection to a computer with a static IP address if not connected to a local network (Peer to Peer). Reference the FH series Operation Manual located on our website for more information.

## Set your computer's static IP address

18. Disconnect the computer from your local network.
19. Turn off Dynamic Host Configuration Protocol (DHCP), if enabled, and create a static IP address for your computer.

**Tip:** The exact steps may vary depending on your operating system.

- a From the Start menu, go to Settings and choose Network Connections.
- b Double-click on the appropriate Local Area Network (LAN).
- c Locate the LAN's Internet Protocol (TCP/IP) properties.
- d Select "Use the following IP address:" and enter the following information:  
IP Address: 192.168.100.101  
Subnet Mask: 255.255.255.0
- e Click OK to submit the changes.

# Series 48™ Air Cooled Laser, FH Marking Head, kit, & WMPv6

SYNRAD  
A Howmet company

## Control Connections (Continued):

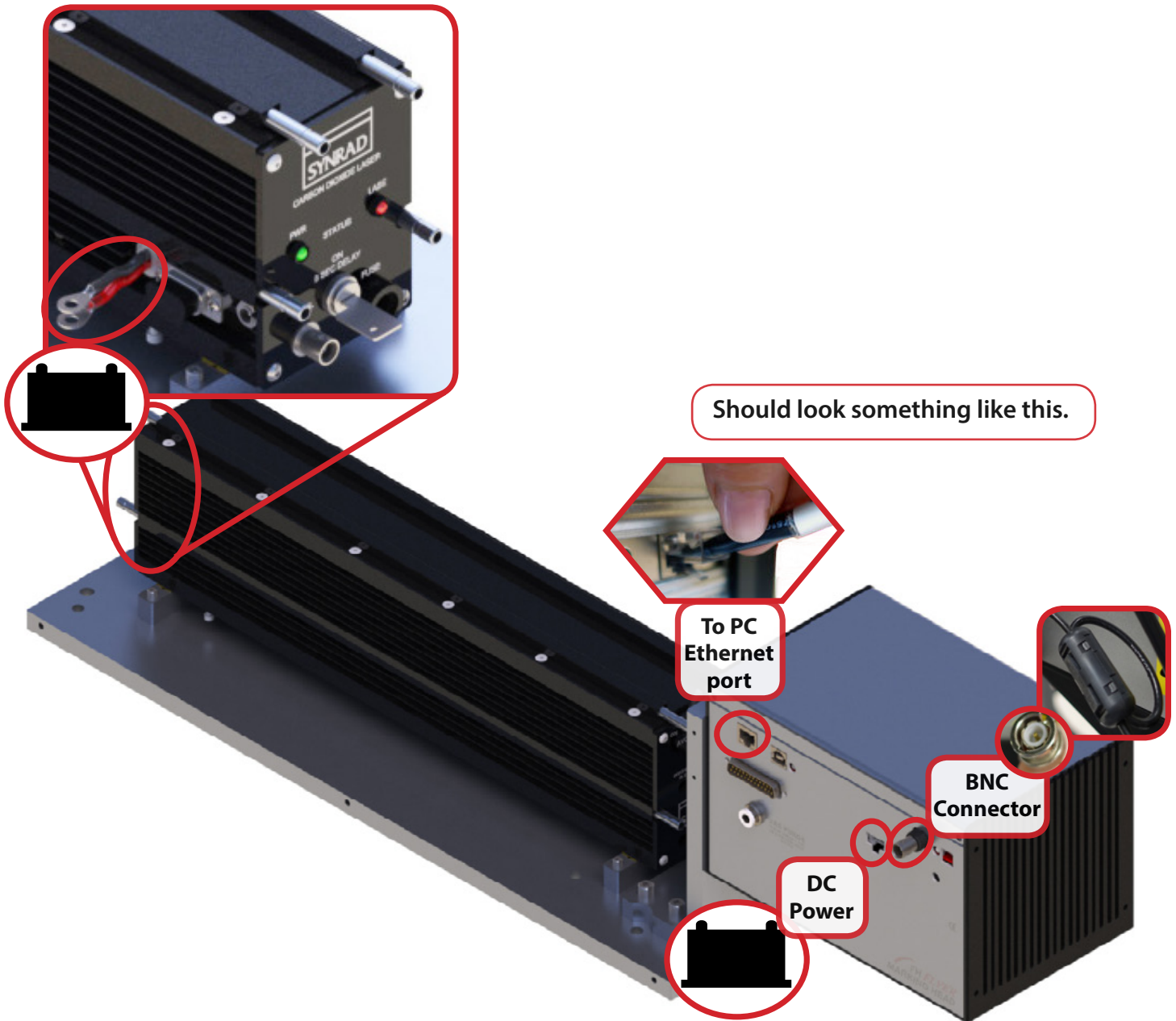

## Important Note:



Read all ⚠ Danger, ⚠ Warning, ⚠ Caution terms, symbols, and instructions located in the (Laser Safety Hazard information) sections in the WinMarkpro Operation Manual.

Prior to installation of the WinMark pro laser marking software on your computer, review the requirements in the WinMark pro Operation Manual, remove power or unplug the USB cable from the Marking Head to prevent windows from arbitrarily assigning a USB driver that is not compatible with Flyer's USB port protocols. A PDF version is available Online at: [http://www.synrad.com/synrad/docroot/products/marketing\\_heads\\_software/winmark-sw](http://www.synrad.com/synrad/docroot/products/marketing_heads_software/winmark-sw).

## WinMarkpro v6 Installation:

### Note:



Find the [WinMark pro v6 release notes](http://www.synrad.com/synrad/docroot/products/marketing_heads_software/winmark-sw) on our website. Refer to WinMark's website for supported operating systems.

1. Before upgrading to a newer version of WinMark pro, backup all existing .mkh mark files and uninstall prior version(s) of WinMark pro software.
2. Download the latest version 6 WinMark pro driver from our website. Exit all programs prior to Installation. [http://www.synrad.com/synrad/docroot/products/marketing\\_heads\\_software/winmark-sw](http://www.synrad.com/synrad/docroot/products/marketing_heads_software/winmark-sw)
3. To install WinMark pro v6, and associated device drivers on a Windows® 7 or Windows® Vista™ operating system, right-click the 'setup.exe' file and choose 'Run as Administrator...'

## Important Note:



When upgrading from a v4 build to version v6, the WinMark Pro installer automatically performs a "clean install" because v6 is uses a different subset of registry keys. The "Perform Clean Installation" and "Keep Current Program Settings" options are grayed out to indicate this installation is a "clean installation".

Upgrading from one v6 build to another does allow the option of preserving existing WinMark settings in the computer's System Registry. Choose Yes to preserve current WinMark Pro v6 registry settings including custom date code formats, object defaults, shift codes, auto startup info, and saved serial numbers. Choose No to erase all previous WinMark v6 Registry entries and perform a clean installation.

If you install WinMark pro V6 If you install WinMark Pro v6 and later decide to downgrade to WinMark v4, performing a clean installation of v4 will erase v4 and v6 Registry settings.

### Note:



Due to Microsoft's implementation of registry virtualization, Windows Vista may require you to log on as an Administrator to perform certain functions like file importation or to save custom date code formats.

4. To install WinMark Pro v6, and associated device drivers, on a Windows® XP operating system, double-click the 'setup.exe' file.
5. WinMark Pro v6 is a Microsoft .NET™ Framework-based application. If Microsoft .NET Framework Service Pack 1, or higher, is not installed on the computer, the installer will prompt you to click 'Accept' to install the .NET Framework. You must have the .NET Framework runtime and associated files installed to run WinMark Pro.

## WinMark pro v6 Installation (continued):

**Note:** ! If WinMark Pro is un-installed, the .NET package is not removed, because these files may be used by other applications installed after the original WinMark installation.

6. When the .NET Framework installation is complete, reboot if prompted to do so. Otherwise the WinMark installer will continue.
7. If Microsoft C++ Redistributable x86 file runtime components are not installed on the computer, the installer will prompt you to click 'Install' to install C++ Redistributable files. You must have these files installed to run WinMark Pro.
8. Follow instructions in the installer dialog boxes to complete the WinMark Pro installation. You must click 'I Agree' to accept the WinMark Pro license agreement and continue the installation.

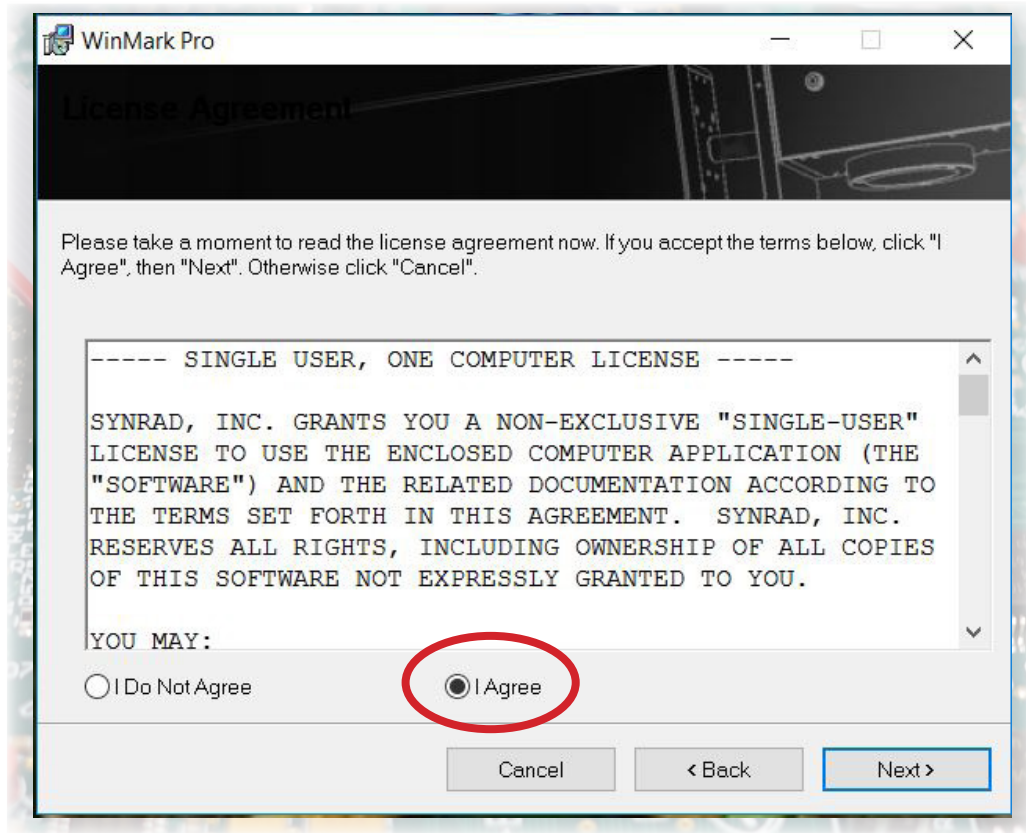

**Note:** ! Beginning with WinMark v6 build 7328, the WinMark installer writes Windows Registry values when installation is complete so there is no need to run WinMark once as an Administrator before other, more restricted users, log on to run WinMark.

9. After installation is complete, remember to turn on any anti-virus software.



# Series 48™ Air Cooled Laser, FH Marking Head, kit, & WMPv6

SYNRAD  
a Synrad company

## WinMark Launcher:

- As part of the software installation, WinMark Launcher (Launcher.exe) is placed in the Program Files/ WinMark folder and a shortcut is placed on the desktop. Launcher allows non-administrative operators to load existing .mkh files for marking without opening WinMark's Drawing Editor by selecting the 'Open Drawing'... from the file menu.

### 10.1 Opening an existing \*.mkh file.

### 11.1 Modifying an existing \*.mkh file.

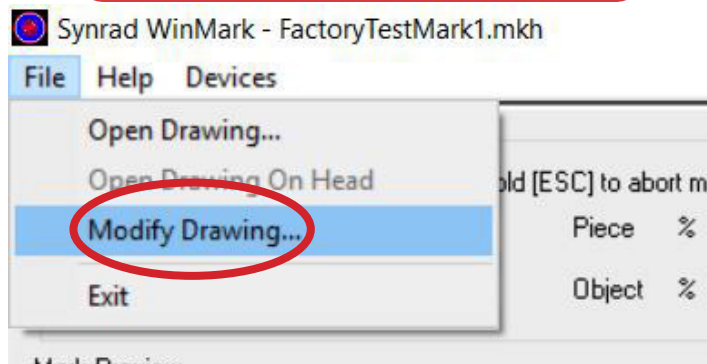
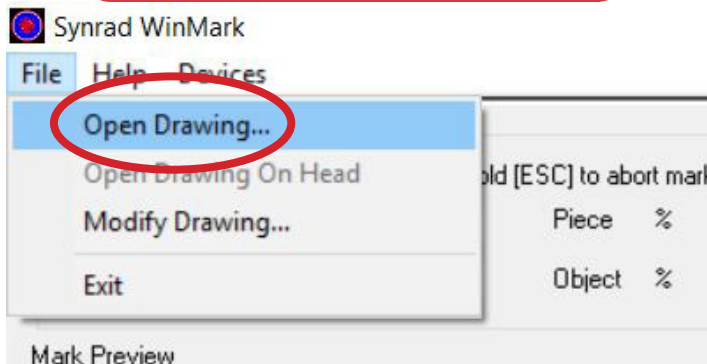

- To add an Admin password so operators cannot 'Modify Drawing'... Select 'Modify Drawing'... which then opens the WinMarkpro application.

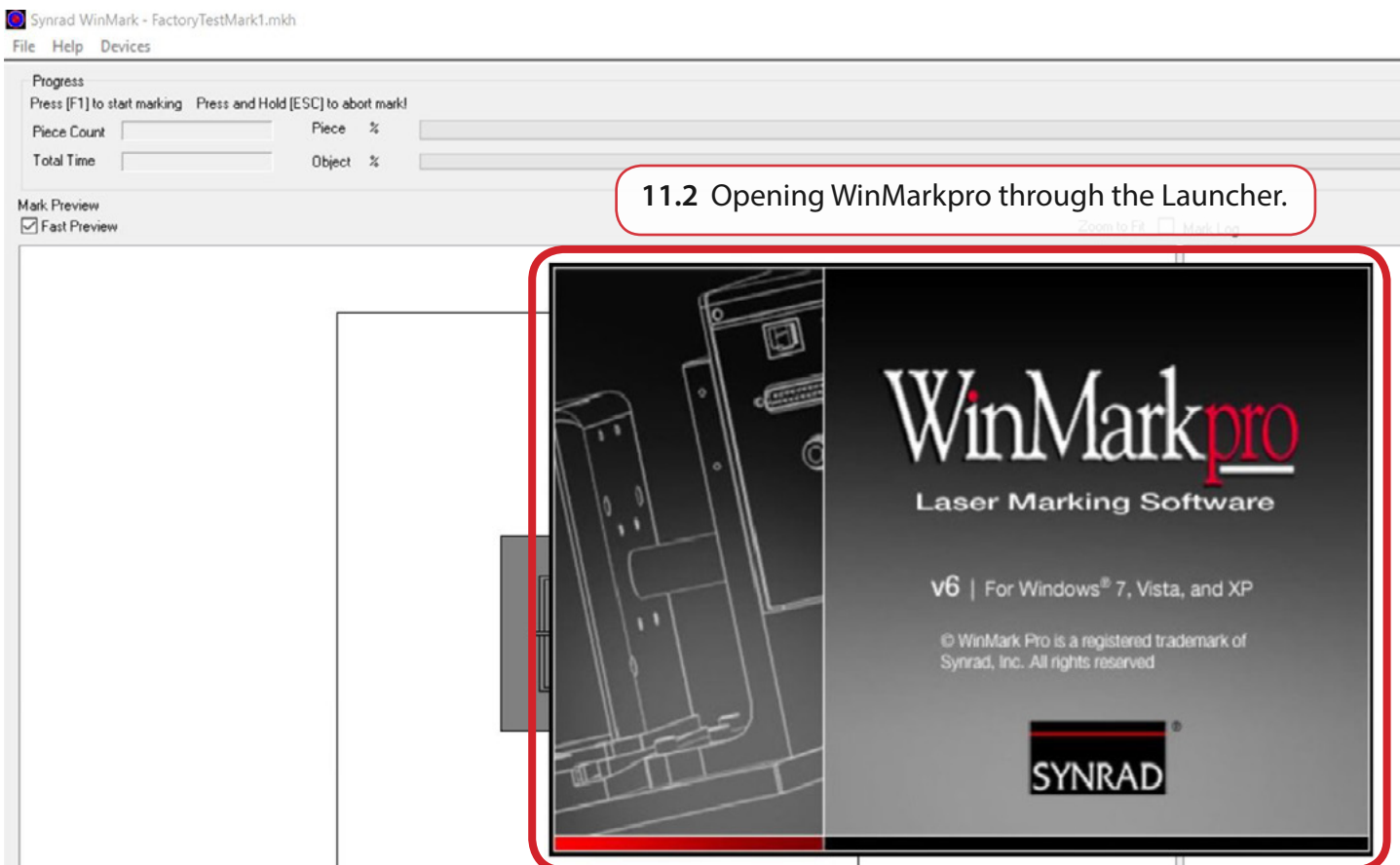

### 11.2 Opening WinMarkpro through the Launcher.

## WinMark pro:

12. Once the WinMark Pro application opens, click the **Tools** menu and select '**General Settings**'...

### 12.1 Password protecting \*.mkh files.

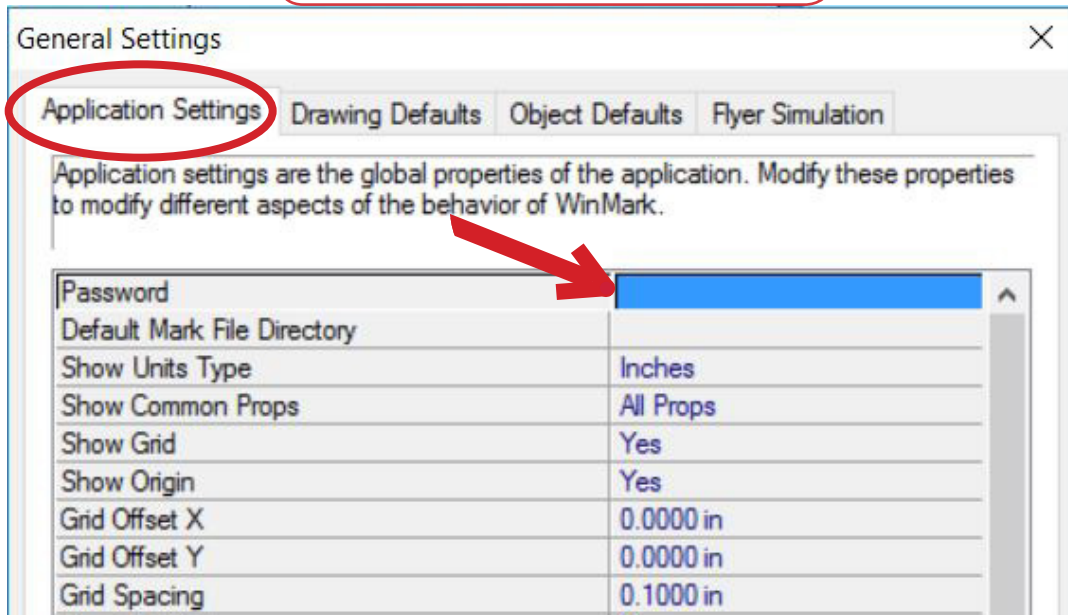

13. Using WinMark Pro's '**Startup Options**'... within the Tools menu, Launcher can be configured to load a specific file and to start marking automatically when the computer is powered up.

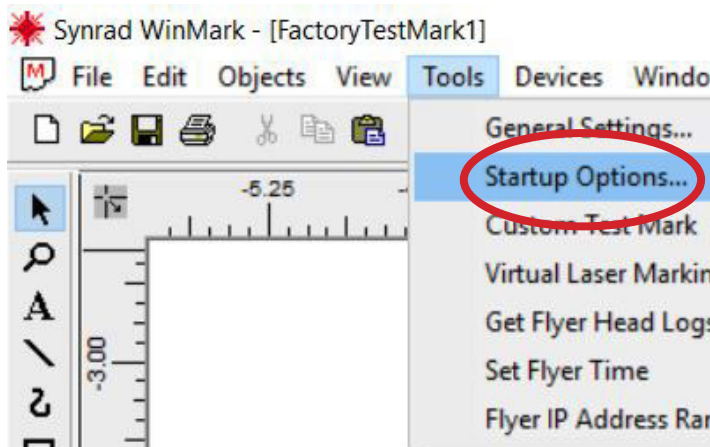

### 13.1 Modifying an existing \*.mkh file.

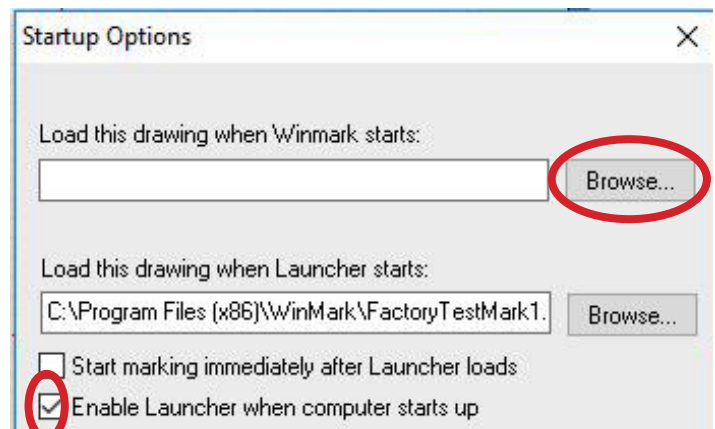

### 13.2 Browsing to the desired startup-file, and automatically launch upon computer startup.

## WinMark Digital Scope:

14. Digital Scope (**DigScope.exe**) is a stand-alone program included in the **WinMark** folder. Use Digital Scope to test individual inputs and outputs, turn the laser beam on or off, or adjust the laser's output power level. This "manual" control is especially useful when testing or troubleshooting I/O connections to/from the marking head.

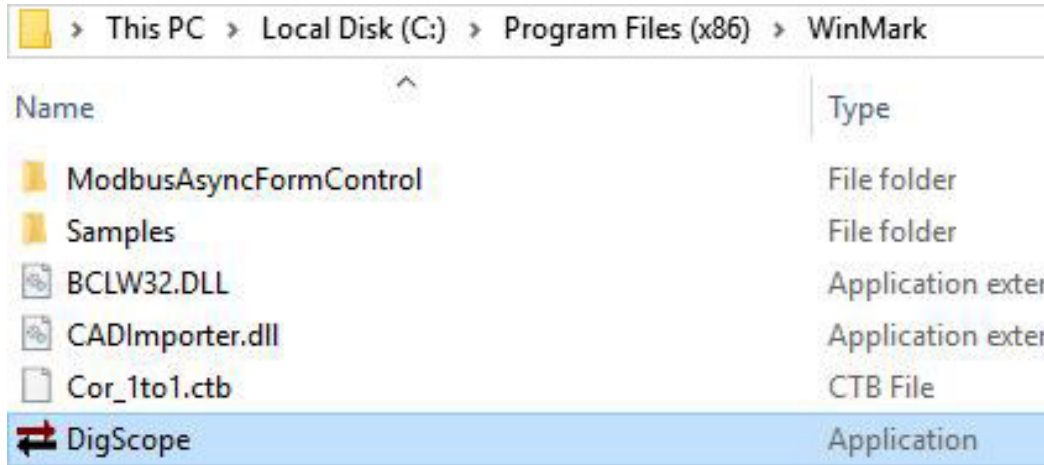

14.1 Digital Scope Application on the WinMark Pro Software CD.

15. The Samples folder is also placed in the WinMark folder during installation. This folder contains a sample communications DLL; Microsoft® Visual Basic®, Microsoft® Visual C++®, and Microsoft® C#® (in a .NET™ framework) sample code that demonstrates the use of WinMark's ActiveMark™ control methods; a folder of importable bitmap and vector graphics files; and sample mark files illustrating all of WinMark Pro's available stroke fonts.

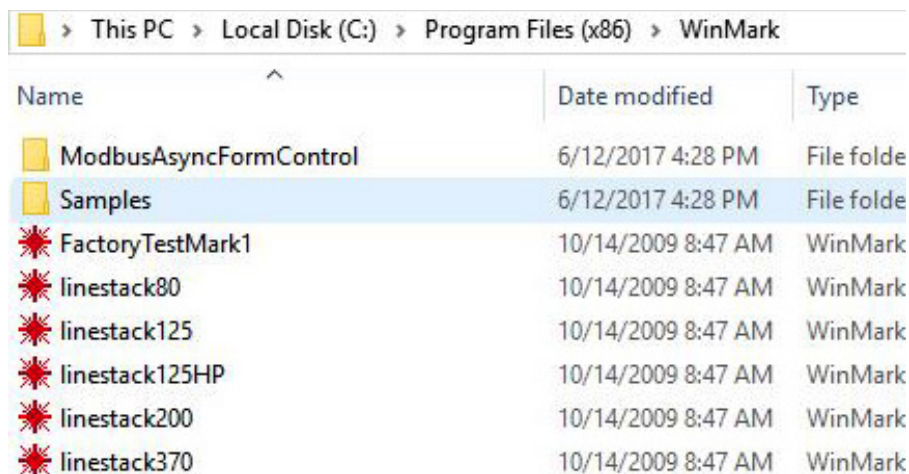

15.1 Samples folder on the WinMark Pro Software CD.

## WinMarkpro v6 Communication Configuration:

Laser Markers are pre-configured at the factory to a fixed address of 192.168.100.100. This allows you to make a peer-to-peer Ethernet connection. Your computer's Ethernet settings are determined by your facility's computer network. The FH Marking Head requires a connection to a computer with a static IP address if not connected to a local network (Peer to Peer). Reference the [FH series Operation Manual](#) located on our website for more information.

### Set your computer's static IP address

20. Disconnect the computer from your local network.
21. Turn off Dynamic Host Configuration Protocol (DHCP), if enabled, and create a static IP address for your computer.

**Note:** ! The exact steps may vary depending on your operating system.

- a From the Start menu, go to Settings and choose Network Connections.
- b Double-click on the appropriate Local Area Network (LAN).
- c Locate the LAN's Internet Protocol (TCP/IP) properties.
- d Select "Use the following IP address:" and enter the following information:  
IP Address: 192.168.100.101  
Subnet Mask: 255.255.255.0
- e Click OK to submit the changes.

## WinMarkpro v6 Configuration (continued) optional USB driver:

WinMark Pro (WMP) installs a specialized USB driver that communicates with the marking head and the Laser (not recommended for manufacturing environments). During computer boot-up, the Windows OS automatically starts the USB driver as a service. Once started, the driver can be accessed by WinMark Pro, WinMark Launcher, or Digital Scope.

**Note:** Before installing or upgrading WinMark Pro software, first disconnect power or unplug the USB cable from the Marking head, this ensures that the Windows OS will load and install the latest marking head USB driver; otherwise, Windows will arbitrarily assign a USB driver that is **not compatible** with the marking head USB port protocols. If this happens, see the Troubleshooting section of the Marking Head's Operator Manual or the WMP Operator's Manual for information on the re-installing the correct USB driver.

## Marking head's USB driver:

WinMark Pro (WMP) installs a specialized USB driver that communicates with the marking head and the Laser. During computer boot-up, the Windows OS automatically starts the USB driver as a service. Once started, the driver can be accessed by WinMark Pro, WinMark Launcher, or Digital Scope.

If the Found New Hardware Wizard dialog appears when your marking head is first connected to the computer's USB port, perform the following steps:

16. Download USB driver from web site, run the USB install.exe. When asked, "Can Windows connect to Windows Update to search for software?" Click '**do not this time**' and click '**Next**'.
17. When prompted, "What do you want the wizard to do?" Click '**Install the software automatically (Recommended)**' and click '**Next**'.
18. Click, "**Finish**" to complete the USB driver installation for the Marking Head device.

## WinMark File Import Filters:

WinMark Pro automatically loads the File Import Filters during installation. These filters allow you to import a wide variety of graphi file formats. See the WinMark pro Operation Manual for details.

After the un-install is complete, some WinMark components, like .MKH mark files, will remain. To completely remove all WinMark-related files, go to C:\Program Files and delete the WinMark folder.

## Uninstalling WinMark Pro:

If you decide to remove WinMark pro software from your computer, perform the following steps:

19. Click the "**Start**" button on the taskbar.
20. Select "**Programs**" and then locate the Synrad WinMark pro folder.
21. Click the "**Uninstall**" Synrad WinMark icon.
22. Follow the on-screen instructions.