

4

3

2

1

NOTES:

- 1. MANUFACTURE IN ACCORDANCE WITH SYNRAD DOCUMENT "WORKMANSHIP STANDARD".
- ② REFERENCE SURFACE FOR WORKING DISTANCE MEASUREMENTS.

REV	ECO	DATE	DESCRIPTION	DB
R1	.	24-Feb-14	INITIAL DESIGN	DMD
.
.

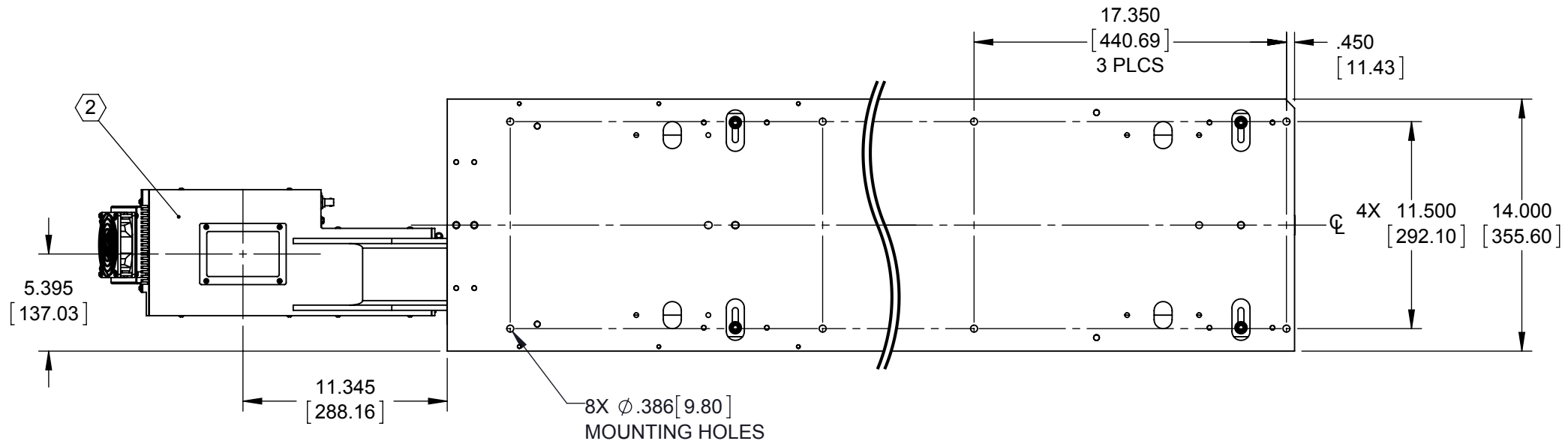
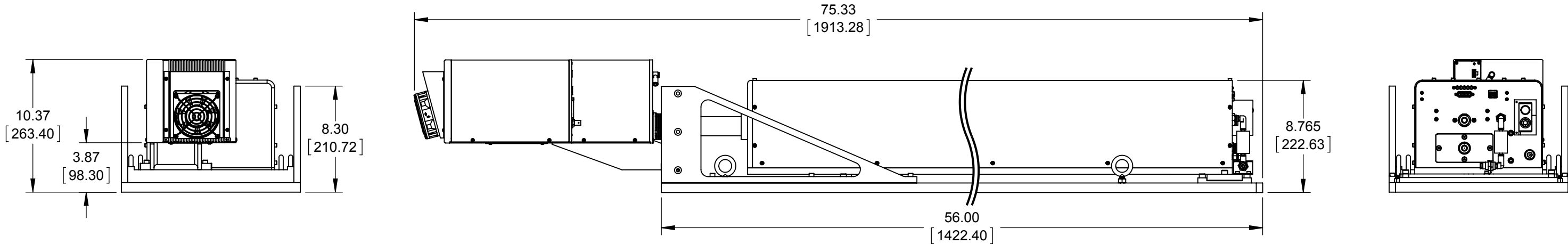

TOLERANCES UNLESS NOTED:		PROPRIETARY THIS DRAWING IS PROPRIETARY TO SYNRAD INC. AND SHALL NOT BE USED OR DISCLOSED IN WHOLE OR IN PART WITHOUT WRITTEN PERMISSION OF SYNRAD INC.		 SYNRAD INC. 4600 Campus Place Mukilteo, WA 98275 Phone: (425)349-3500 Fax: (425)349-3667	
.x = ± .1	ANGLE = ± .5°				
.xx = ± .01					
.xxx = ± .005		DESCRIPTION: OUTLINE & MOUNTING, FLYER 3D/P250			
MATERIAL:		PART NUMBER: 300-20818-09		DWG/FILE NUMBER: 300-20818-09	
FINISH:		SHEET 1 of 1	ENG: .	DRAWN BY: D. DUVAL	DATE: 24-Feb-14
		UNITS: Inches	CATEGORY: .	CHECKED BY:	DATE:
		SIZE: B	FINISH CLASS: .	APPROVED BY:	DATE:
					REV. R1

4

3

2

1