

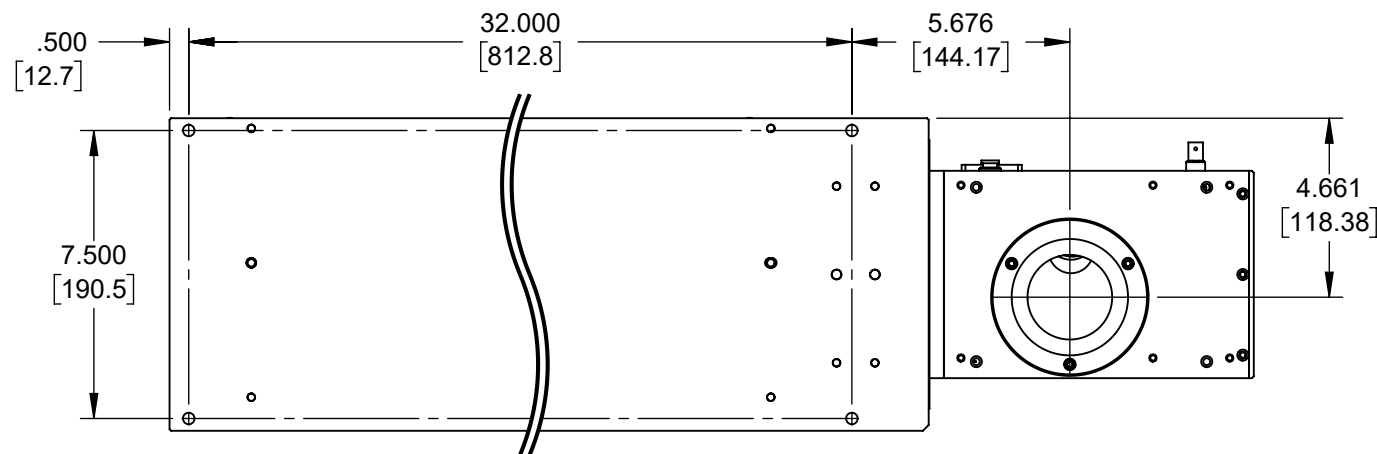

NOTES:

1. DIMENSIONING AND TOLERANCING TO BE INTERPRETED PER ASME Y14.5M-1994.

REV	DA	ECN	ECO	DATE	DESCRIPTION	DB
01	.	.	.	1-Feb-19	INITIAL DESIGN	DMD
.
.

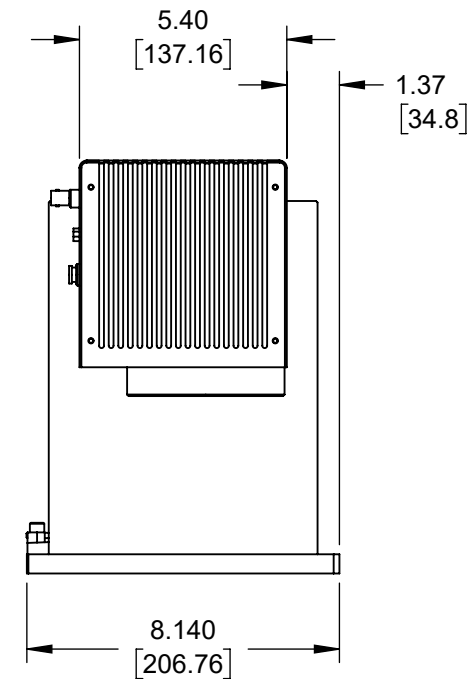
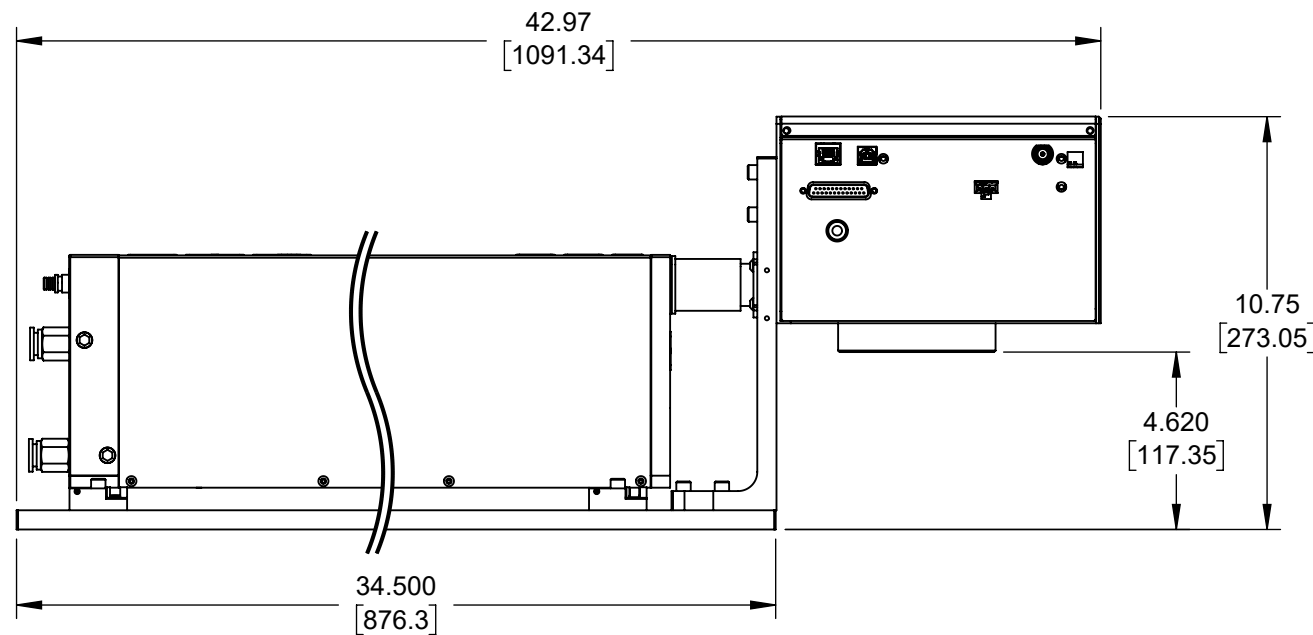
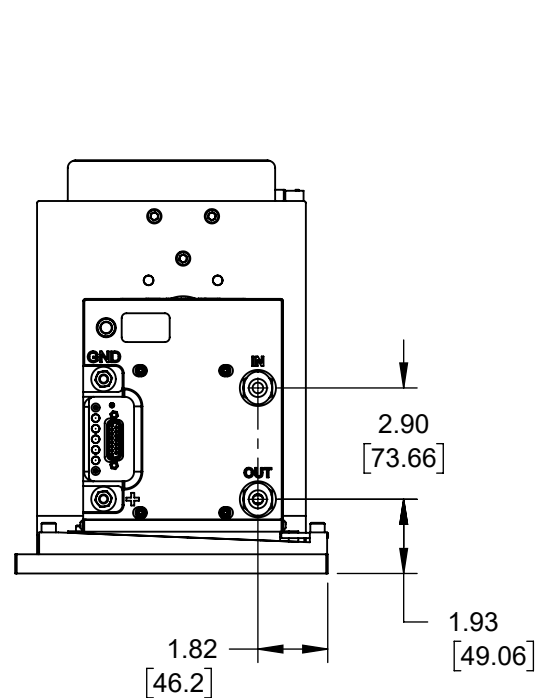

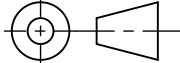
TOLERANCES UNLESS NOTED:		PROPRIETARY: THIS DRAWING IS PROPRIETARY TO SYNRAD, A NOVANTA COMPANY, AND SHALL NOT BE USED OR DISCLOSED IN WHOLE OR IN PART WITHOUT WRITTEN PERMISSION FROM SYNRAD AND/OR NOVANTA.		 SYNRAD A Novanta Company	SYNRAD 4600 Campus Place Mukilteo, WA 98275 Phone: (425)349-3500 Fax: (425)349-3667
.x = ± .1	ANGLE = ±.5°	THIRD ANGLE PROJECTION			
.xx = ± .01				OUTLINE & MOUNTING, FLYER/P150	
.xxx = ± .005					
MATERIAL:		DESCRIPTION:			
.		DRAWN BY: D. DUVALL			
.		DATE: 1-Feb-19		DWG/FILE NUMBER: 300-19676-90	
.		QTY CHK BY:		PART NUMBER: 300-19676-90	
SURFACE TEXTURE: N/A		ENG CHK BY:		ENG: .	SIZE: B
		APPROVED BY:		UNITS: Inches	SHEET 1 of 1
				FINISH CLASS: .	REV. 01